

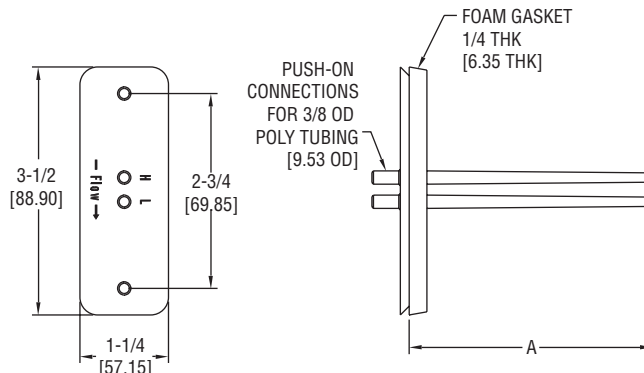

**Series SSS-1000 Lightweight Averaging Flow Sensor**

**Specifications - Installation and Operating Instructions**



**DIMENSIONS**

Model	Length (A)
SSS-1002	3-5/32" (80.17 mm)
SSS-1003	5-13/32" (137.32 mm)
SSS-1004	7-21/32" (195.47 mm)
SSS-1005	9-29/32" (252.62 mm)

The Series SSS-1000 Lightweight Averaging Flow Sensor from Dwyer Instruments is ideal for sensing differential pressure in the inlet section of variable air volume terminal units and fan terminal units. They can also be used to sense differential pressure at other locations in the main, or branch duct systems.

The "H" port senses total pressure and the "L" port senses static pressure. The difference between these signals is the differential, or velocity pressure.

Models offer up to four sensing points and lengths of 3-5/32" to 9-29/32" (8.02 to 25.26 cm) to accommodate box size diameters of 4" to 16" (10.16 to 40.64 cm).

**INSTALLATION**

The Series SSS-1000 utilizes 1/4" I.D. tubing for 3/8" O.D. tubing. First check that there are no sharp bends in the tubing at any connection. Bends and creases may leak over time as the tubing ages.

Connect the "H" Port to the high input on the differential pressure gage, transmitter, or switch.

Connect the "L" Port to the low input on the differential pressure gage, transmitter, or switch.

**SPECIFICATIONS**

**Service:** Air and compatible gases.

**Wetted Materials:** ABS/Polycarbonate (UL94-5V).

**Temperature Limits:** Operating: 40 to 120°F (4 to 49°C); Storage: -40 to 140°F (-40 to 60°C).

**Connection:** 1/4" (6 mm) I.D. tubing for 3/8" (10 mm) O.D. tubing.

**Mounting Orientation:** Integral flange with gasket.

**Weight:** 1 oz (28 g).

**CONNECTION CURVE**

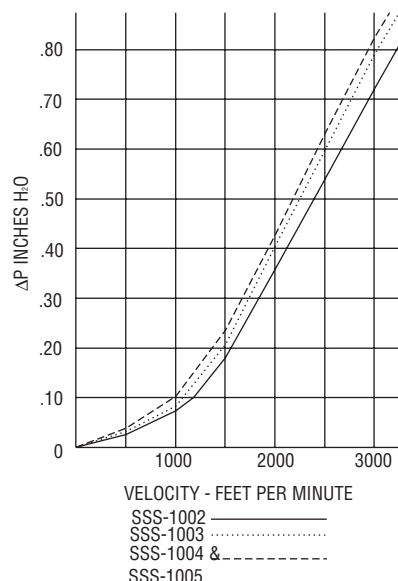

**MOUNTING**

1. Install the unit horizontally to assure accurate velocity readings.
2. Determine the duct's flow direction and install the Series SSS-1000 based on the unit's flow arrow imprint.
3. Cut a 7/8" hole in the ducting to accept the unit.
4. Attach using two self-tapping screws inserted in the 3/16" mounting holes.

**MAINTENANCE**

Sensing orifices must be kept free of dust accumulation or debris.

The Series SSS-1000 Lightweight Averaging Flow Sensors are not field repairable. If you wish to return a unit contact customer service to receive a return goods authorization number before shipping.

**MOUNTING DETAILS**