

2300 SYSTEM

Signal Conditioning Amplifier

2310B

Instruction Manual



Vishay Micro-Measurements

P.O. Box 27777
Raleigh, NC 27611
United States
Telephone +1-919-365-3800
FAX +1-919-365-3945
E-mail: vmm.us@vishaymg.com
www.vishaymg.com

**INSTRUCTION MANUAL
MODEL 2310B
SIGNAL CONDITIONING AMPLIFIER**

1.0 DESCRIPTION	3
1.1 GENERAL	3
1.2 SIGNIFICANT FEATURES	3
2.0 SPECIFICATIONS	3
2.1 2310 SIGNAL CONDITIONING AMPLIFIER	3
2.2 2350 RACK ADAPTER	4
2.3 2360 PORTABLE ENCLOSURE	4
3.0 CONTROLS	5
3.1 2310 FRONT PANEL	5
3.2 2310 REAR PANEL	6
4.0 OPERATING PROCEDURE	7
4.1 SETUP AND AC POWER	7
4.2 GAGE INPUT CONNECTIONS	7
4.3 MILLIVOLT INPUTS	8
4.4 WIRING CONSIDERATIONS	8
4.5 OUTPUT CONNECTIONS	9
4.7 FILTER OUTPUT SELECTOR	10
4.8 EXCITATION	10
4.9 AMPLIFIER BALANCE	11
4.10 BRIDGE BALANCE	11
4.11 BATTERY TEST	11
4.12 GAIN	11
4.13 FILTER	12
4.14 DYNAMIC TESTING	13
4.15 TAPE PLAYBACK	13
4.16 REMOTE-OPERATION RELAYS	14
4.17 QUARTER-BRIDGE NONLINEARITY	14
5.0 SHUNT CALIBRATION	14
5.1 INTRODUCTION	14
5.2 SHUNT CALIBRATION COMPONENTS IN 2310	15
5.3 SHUNT CALIBRATION — STRESS ANALYSIS	15
5.4 TRANSDUCERS	16
5.5 STANDARD CALIBRATION RESISTORS	18
6.0 ACTIVE FILTER	19
6.1 FILTER CHARACTERISTICS	19
7.0 MAINTENANCE	20
7.1 ADJUSTMENTS	20
7.2 BATTERY REPLACEMENT	22
7.3 COMPONENT REPLACEMENT	22
7.4 FUSE REPLACEMENT	23
APPENDIX	23
WARRANTY	24

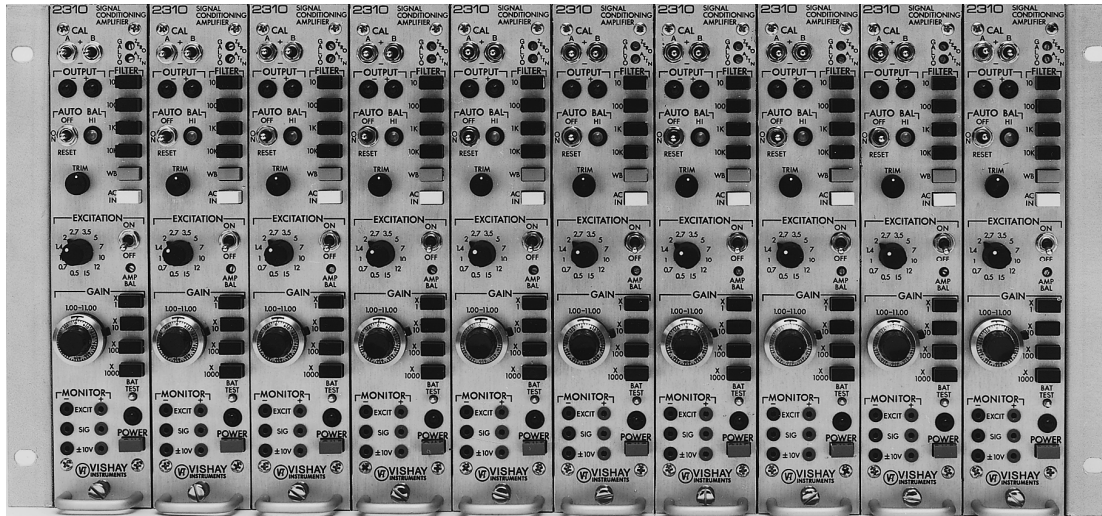

Complete 10-Channel 2300 System

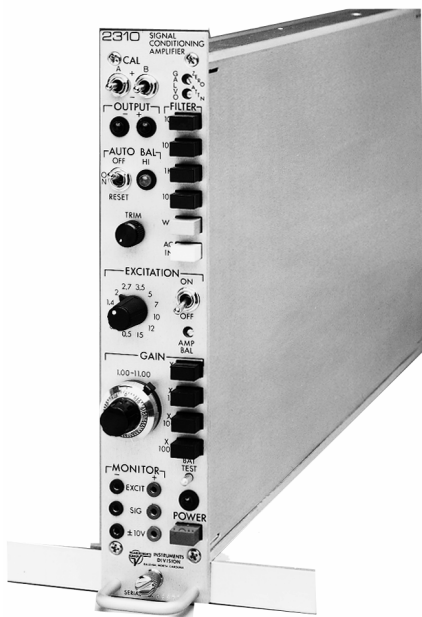

*2310 Signal Conditioning Amplifier
Module with Stabilizer Accessory*



4-channel System in 2360 Portable Enclosure



2350 10-Channel Rack Adapter

1.0 DESCRIPTION

1.1 GENERAL

The 2300 Series instruments comprise a versatile multi-channel system for conditioning and amplifying low-level signals from strain gages (or strain gage based transducers) for display or recording on external equipment. Each 2310B Signal Conditioning Amplifier is separately powered and electrically isolated from all others (and can be powered with a separate line cord), although groups of amplifiers are normally inserted into a multi-channel rack adapter or portable enclosure.

The Model 2350 Rack Adapter accepts up to ten 2310B Amplifiers for mounting in a standard 19-in (483-mm) rack; the Model 2360 Portable Enclosure accepts up to four 2310B Amplifiers for more portable use.

Each Model 2310B Amplifier incorporates precision high-stability bridge completion resistors and dummy gages, and four shunt-calibration resistors, and is complete and ready for use as delivered — only ac power is required via the Portable Enclosure, Rack Adapter or separate ac line cord. Input and output connectors are supplied with each amplifier.

1.2 SIGNIFICANT FEATURES

The 2300 Series is designed to provide features essential for accurate stress analysis data in a broad range of measurement applications. Principal features include:

- Fully adjustable calibrated gain from 1 to 11 000.
- Accepts all strain gage inputs (foil or piezoresistive), potentiometers, DCDT's, etc.
- Bridge excitation from 0.7 to 15Vdc (11 steps) plus 0.2 to 7 Volts continuously variable.
- Input impedance above 100 megohms.
- Two simultaneous buffered outputs: $\pm 10V$, $\pm 1.4V$ (for tape recorders).
- Wide band operation exceeding 60 kHz, -0.5 dB at all gains and output levels.
- Four-frequency active 6-pole filter (10 to 10 000 Hz).
- Dual-range (± 5000 and $\pm 25000\mu\epsilon$) automatic bridge balance, with keep-alive power to preserve balance for months without external power.
- Dual-polarity two-step double-shunt calibration.
- Optional remote calibration and auto balance reset.
- Playback mode to filter and observe or re-record previously recorded magnetic tape data.
- And many other convenience features.

2.0 SPECIFICATIONS

All specifications are nominal or typical at +23°C unless noted. Performance may be degraded in the presence of high-level electromagnetic fields.

2.1 2310B SIGNAL CONDITIONING AMPLIFIER

INPUT:

Strain gages: quarter, half or full bridge (50 to 1000 Ω). Built-in 120 Ω and 350 Ω dummy gages; 1000 Ω dummy capability. See Appendix, page 23.

Transducers: foil or piezoresistive strain gage types; DCDT displacement transducers; potentiometers.

EXCITATION:

Eleven settings: 0.7, 1, 1.4, 2, 2.7, 3.5, 5, 7, 10, 12 and 15 Vdc $\pm 1\%$ max. One variable setting : 0.2 to 7 Vdc

Current: 0-100 mA, min, limited at 175 mA, max.

Regulation (0-100 mA $\pm 10\%$ line change): ± 0.5 mV $\pm 0.04\%$, max measured at remote sense points. (Local sense: -5 mV, typical, @ 100 mA, measured at plug.)

Remote sense error: 0.0005% per ohm of lead resistance (350 Ω load).

Noise and ripple: 0.05% p-p, max (dc to 10 kHz).

Stability: $\pm 0.02\%/^{\circ}C$.

Level: normally symmetrical about ground; either side may be grounded with no effect on performance.

BRIDGE BALANCE:

Method: counter-emf injection at pre-amp; automatic electronic; dual range; can be disabled on front panel.

Ranges (auto ranging):

$\pm 5000\mu\epsilon$ ($\pm 1\%$ bridge unbalance or ± 2.5 m V/V), resolution 2.5 $\mu\epsilon$ (0.0012 mV/V).

$\pm 25\ 000\mu\epsilon$ ($\pm 5\%$ bridge unbalance or ± 12.5 mV/V), resolution 12.5 $\mu\epsilon$ (0.006 mV/V).

Balance time: 2 seconds, typical.

Manual vernier balance range: 100 $\mu\epsilon$ (0.050 mV/V).

Interaction: essentially independent of excitation and amplifier gain.

Storage: non-volatile digital storage without line power for up to two years.

SHUNT CALIBRATION:

Circuit (two-level, dual polarity): Single-shunt (for stress analysis) across any bridge arm, including dummy gage.

Double-shunt (for transducers) across opposite bridge arms.

Provision for four dedicated leads to shunt external arms.

CAL circuit selected by switches on p.c. board.

Standard factory-installed resistors ($\pm 0.1\%$) simulate:

± 200 and $\pm 1000\mu\epsilon$ @ GF=2 across dummy half bridge;

$\pm 1000\mu\epsilon$ @ GF=2 across dummy gage (120 Ω and 350 Ω).

± 1 mV/V (double shunt) for 350 Ω transducer.

Remote-operation relays (Option Y): four relays (plus remote-reset relay for bridge balance and relay for excitation on/off). Each relay requires 10 mA @ 5 Vdc, except excitation on/off 25 mA.

AMPLIFIER

Gain: 1 to 11 000 continuously variable. Direct-reading, $\pm 1\%$ max. 10-turn counting knob (X1 to X11) plus decade multiplier (X1 to X1000)

Frequency response, all gains full output:

dc coupled: dc to 125 kHz, -3 dB max.
dc to 55 kHz, -0.5 dB max.

ac coupled: 1.7Hz typ. to 125 kHz, -3 dB max.

Frequency response versus gain, full output:

GAIN	-0.5db	-3 db
1-11	120 kHz	300 kHz
10-110	90 kHz	230 kHz
100-1100	70 kHz	150 kHz
1000-11000	55 kHz	125 kHz

Input impedance: 100 M Ω , min, differential or common-mode, including bridge balance circuit.

Bias current: ± 40 nA, typical max., each input.

Source impedance: 0 to 1000 Ω each input.

Common-mode voltage: ± 10 V.

Common-mode rejection (gain over X100):

Shorted input: 100dB, min, at dc to 60 Hz;
90 dB, min, dc to 1 kHz;

350 Ω balanced input: 90 dB, typical, dc to 1 kHz.

Stability (gain over X100): ± 2 μ V/ $^{\circ}$ C, max, RTI (referred to input).

Noise (gain over X100, all outputs):

0.01 to 10 Hz: 1 μ V p-p RTI.

0.5 to 125 kHz: 6 μ Vrms, max, RTI.

FILTER:

Characteristic:

Low-pass active six-pole Butterworth standard.

Frequencies (-3 ± 1 dB): 10, 100, 1000 and 10 000 Hz and wide-band.

Outputs filtered: either one or both (switch-selected on p.c. board).

AMPLIFIER OUTPUTS:

Standard output: ± 10 V @ 5 mA, min.

Tape output: ± 1.414 V (1 Vrms) @ 5 mA, min.

Linearity @ dc: $\pm 0.02\%$.

Either output can be short-circuited with no effect on the other.

PLAYBACK:

Input: ± 1.414 V full scale; input impedance 20 k Ω .

Gain: X1 to tape output; X7.07 to standard output.

Filter selection: as specified above.

Outputs: Both as specified above.

OPERATING ENVIRONMENT:

Temperature: 0 $^{\circ}$ to +50 $^{\circ}$ C.

Humidity: 10 to 90%, non-condensing.

POWER:

105 to 125V or 210 to 250V (switch-selected), 50/60 Hz, 10 watts, max.

Keep-alive supply (for bridge balance): Lithium 3.6V, 1/2AA or equal. Shelf life approximately two years.

SIZE & WEIGHT:

Panel: 8.75 H x 1.706 W in (222.2 x 43.3 mm).

Case depth behind panel: 15.9 in (404 mm).

Weight: 6 lb (2.7 kg).

2.2 2350 RACK ADAPTER

APPLICATION:

Fits standard 19-in (483-mm) electronic equipment rack.

Accepts up to ten 2310B Amplifiers. AC line completely wired.

Wiring for remote calibration with Option Y.

POWER:

115 or 230 Vac switch selected in amplifiers, 50/60 Hz, 100 Watts max.

SIZE & WEIGHT:

8.75 H x 19 W x 19.06 D overall (222 x 483 x 484 mm).

13.5 lb (6.1 kg).

2.3 2360 PORTABLE ENCLOSURE

DESCRIPTION:

Enclosure to accept up to four 2310B Amplifiers.

AC wiring complete.

Wiring for remote calibration with Option Y.

POWER:

115 or 230 Vac switch selected in amplifiers, 50/60 Hz, 40 Watts max.

SIZE & WEIGHT:

9.06 H x 7.20 W x 18.90 D in

(229 x 183 x 480 mm)

6.75 lb (3.1 kg).



2310B Front Panel

3.0 CONTROLS

The following functional descriptions are of a general character for information only. The operating procedure is covered in *Section 4.0*.

3.1 2310B FRONT PANEL

CAL Switches: Toggle switches to place shunt-calibration resistors across arms of the input bridge. “A” and “B” may simulate different input levels. (See *5.5 Standard Calibration Resistors* for standard factory-installed resistors.)

OUTPUT Lamps: LED indicators which always monitor the output. Primarily used to adjust AMP BAL and check bridge balance. Fully lit with 0.04 volt at ± 10 V Output.

AUTO BAL Controls: The toggle switch has three positions to control operation of the automatic bridge balance circuit:

OFF (up) disables the circuit; the amplifier outputs now represent true unbalance of the input bridge; stored balance point is retained.

ON (center) enables the automatic bridge balance circuit.

RESET (momentary down) triggers the automatic bridge balance circuit to seek a new balance point. (The prior stored balance point is replaced.)

The “HI” lamp (yellow LED) lights when the automatic balance circuit is in its high range; it indicates a bridge unbalance exceeding 1%. If the unbalance exceeds 5% this lamp will cycle on and off continuously.

TRIM Control: A vernier control to refine bridge balance when desired. Normally the automatic balance circuit will achieve balance within several microstrain.

FILTER Buttons: Push buttons to reduce the upper frequency cut-off (10 to 10 000 Hz) to reject undesired noise during lower-frequency tests. Normally the “WB” button would be depressed, achieving wide-band operation (typically 125 kHz at -3 dB).

The “IN” position of the “AC IN” button (alternate action) ac-couples the amplifier thus eliminating the dc component of the input signal. (However, modest bridge balance is still required — see *4.14 Dynamic Testing*.)

EXCITATION Controls: The rotary switch selects the desired bridge excitation. Most steps approximately double the power dissipation in the bridge arms.

The toggle switch turns bridge power on or off. (Any amplifier output in the OFF position is dc amplifier offset, thermal emf from the bridge, or ac pickup in the wiring.)

AMP BAL: A trimmer to adjust the amplifier balance (EXCITATION should be OFF when this is adjusted).

GAIN Controls: Amplifier gain is the reading of the 10-turn control (1000 to 11 000) multiplied by the selected push button (X1 to X1000).

The indicated gain is the gain from the input to the $\pm 10V$ Output. At the TAPE Output the gain will be lower by a fixed factor of 7.07.

The 10-turn counting knob is equipped with a lock that is engaged by pulling the lever *away* from the front panel and then displacing it downward.

MONITOR Jacks: Three pairs of jacks accepting 0.080-in (2-mm) diameter plugs to monitor bridge excitation (EXCIT), bridge output (SIG) and the amplifier output ($\pm 10V$). Except for $\pm 10V$ return (black jack), 10K resistors are in series with these jacks to provide noise isolation.

BAT TEST: A momentary push button to check the keep-alive batteries for the automatic bridge balance circuit. (See 4.11 *Battery Test*.)

POWER Button: An alternate-action push button (and LED indicator lamp) to turn ac power “on” and “off”. (Bridge balance is retained even with POWER off or the amplifier unplugged.)

3.2 2310B REAR PANEL

PLAYBACK Switch: The ON (up) position connects the adjacent Tape Recorder INPUT coaxial BNC connector to the input of the filter circuits (if selected on the front panel) and post amplifiers. Full-scale input is $\pm 1.4V$. Both outputs are operable.

NOTE: This recessed switch must be returned to the NORM position to monitor incoming signals at the INPUT connector.

$\pm 10V$ Connector: A coaxial BNC connector for the $\pm 10V$ Output of the amplifier. The $\pm 10V$ Output is typically connected to oscilloscopes, DVM’s, analog multiplexers, etc.

TAPE Connector: A coaxial BNC connector providing the output normally used with tape recorders. Full scale is $\pm 1.414V$ (1 Vrms for sine waves).

INPUT Receptacle: A 15-pin quarter-turn connector to connect the input circuit to the 2310B. Quarter, half, and full bridges, potentiometers, or voltage inputs can be accepted simply by using the appropriate pins; see 4.2 *Gage Input Connections* for details. Mating plug supplied.

NOTE: PLAYBACK switch must be set to the NORM position to monitor incoming signals at the INPUT connector.

POWER Connector: A male rack-and-panel connector which supplies ac power in the instrument. Normally, it engages with a powered connector in the rack adapter; an individual line cord is available for servicing by qualified technicians only; see paragraph 4.1e.

Prewired for remote operation of shunt calibration, bridge excitation, and automatic bridge balance. [See 4.16 *Remote-Operation Relay (Option Y)*.]

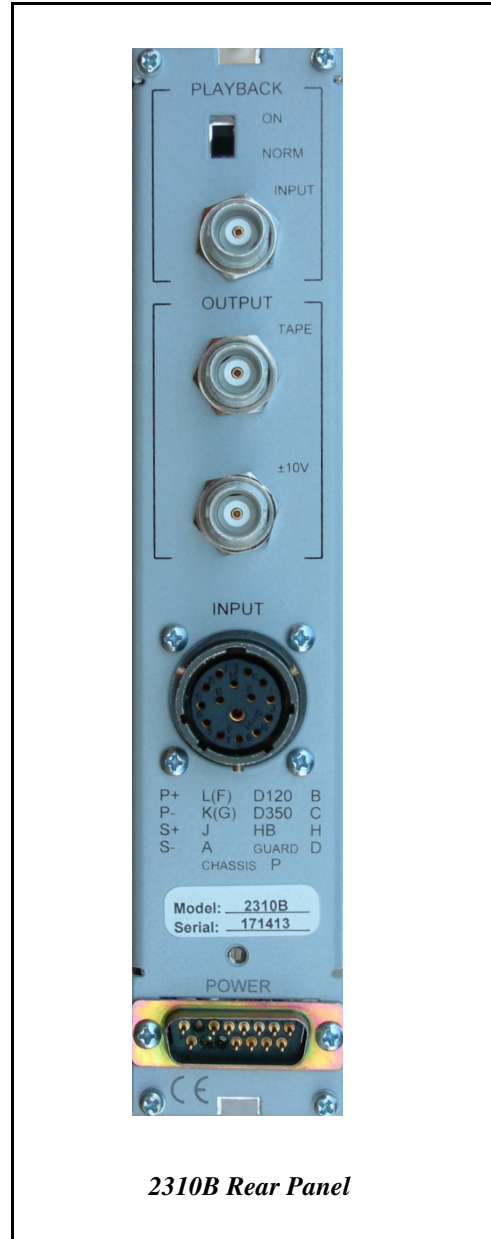

2310B Rear Panel

4.0 OPERATING PROCEDURE

Prior to taking any readings with the 2310B, each FILTER and GAIN push-button switch should be exercised several times for best performance and stability.

4.1 SETUP AND AC POWER: Each 2310B Signal Conditioning Amplifier has its own power supply and may be operated as a freestanding unit (see paragraph 4.1e), or one or more 2310B's may be inserted into the Model 2350 Rack Adapter or the Model 2360 Portable Enclosure.

CAUTION: Prior to removing or installing the 2310B Amplifier or the 2331 Digital Readout into a rack adapter or enclosure, the ac power cord must first be unplugged. Refer system setup and all servicing to qualified technicians. If the 2300 System is used in a manner that is not in accordance with instructions and its intended use, the protection provided by the equipment may be impaired.

4.1a Turn off all 2310B Amplifiers before inserting them into the rack adapter or cabinet; the red POWER button should be in the "out" position, protruding about 1/4 in (6 mm) from the panel.

4.1b Inside of each 2310B, between the rear panel and transformer, set the AC LINE slide switch to the nominal ac line voltage to be used (115 or 230V).

Also on the rear panel check that the recessed PLAYBACK switch is at the NORM (down) position.

4.1c Install the 2310B Amplifiers into the rack adapter or cabinet, securing the thumb-screw at the bottom of each front panel.

4.1d Plug the detachable line cord(s) into the appropriate 2350/2360 receptacle(s).

4.1e To power a freestanding 2310B for only troubleshooting/servicing by qualified service personnel, an individual power cord is required.

A non-CE-approved accessory line cord is available from Vishay Micro-Measurements as part number 120-001196.

4.1f The line cord should be plugged into an ac receptacle which has a good earth ground for the third pin.

NOTE: If the plug on the power cord must be replaced with a different type, observe the following color code when wiring the new plug:

Black or brown: High line voltage

White or blue: Low line voltage ("neutral" or "common")

Green or green/yellow: Earth ground

4.2 GAGE INPUT CONNECTIONS

It is suggested that the 2310B be turned on (press the red POWER button) and allowed to stabilize while

preparing the input connectors. To prevent powering the input bridge circuits at this time, turn the EXCITATION rotary switch to 0.7V and the toggle switch to OFF.

4.2a Each amplifier uses a separate input plug, which is supplied. Additional plugs are available from Vishay Micro-Measurements (see 7.4 **Component Replacement**) or from the plug manufacturer or distributor. Suggested types:

Amphenol/Bendix PT06A-14-15 (SR)
ITT/Cannon KPT06B14-15P

These connectors are designed to MIL-C-26482 and may be available from other manufacturers. As an aid to the technician, the pin arrangement for the Input plug is shown in Figure 1.

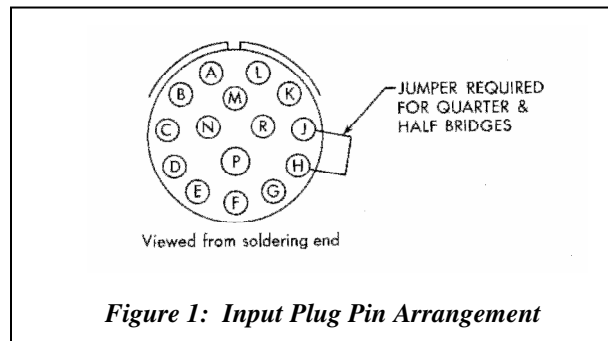

Figure 1: Input Plug Pin Arrangement

4.2b The basic input arrangements are shown in Figure 2. Note that, except when using an external full bridge, there must be a jumper in the input plug connecting pins H and J; this connects the midpoint of the internal half bridge to the S+ amplifier input. Precision 120Ω and 350Ω dummy gages are provided in each Model 2310B. If using a quarter bridge with resistance other than 120Ω, 350Ω, or 1000Ω, use circuit A2 in Figure 2. For 1000Ω quarter bridges, see Appendix.

4.2c When using an external full bridge (especially a precision transducer), it may be desirable to employ the remote-sense circuitry provided in the 2310B to maintain constant excitation at the transducer regardless of lead resistance. To enable this circuit, open the right side-cover of the 2310B and raise the small red SENSE switch to REMOTE (see Figure 4). Connect the sense leads between the transducer and pins F and G of the INPUT plug as shown in Figure 2, C2.

4.2d If it is desired to employ shunt-calibration across one of the external bridge arms, additional wiring is required to achieve maximum accuracy (see 5.0 **Shunt Calibration** for details). However, for half- or quarter-bridge inputs, shunting the internal dummy half bridge or dummy gage is normally recommended; neither of these circuits requires additional wiring from that shown in Figure 2.

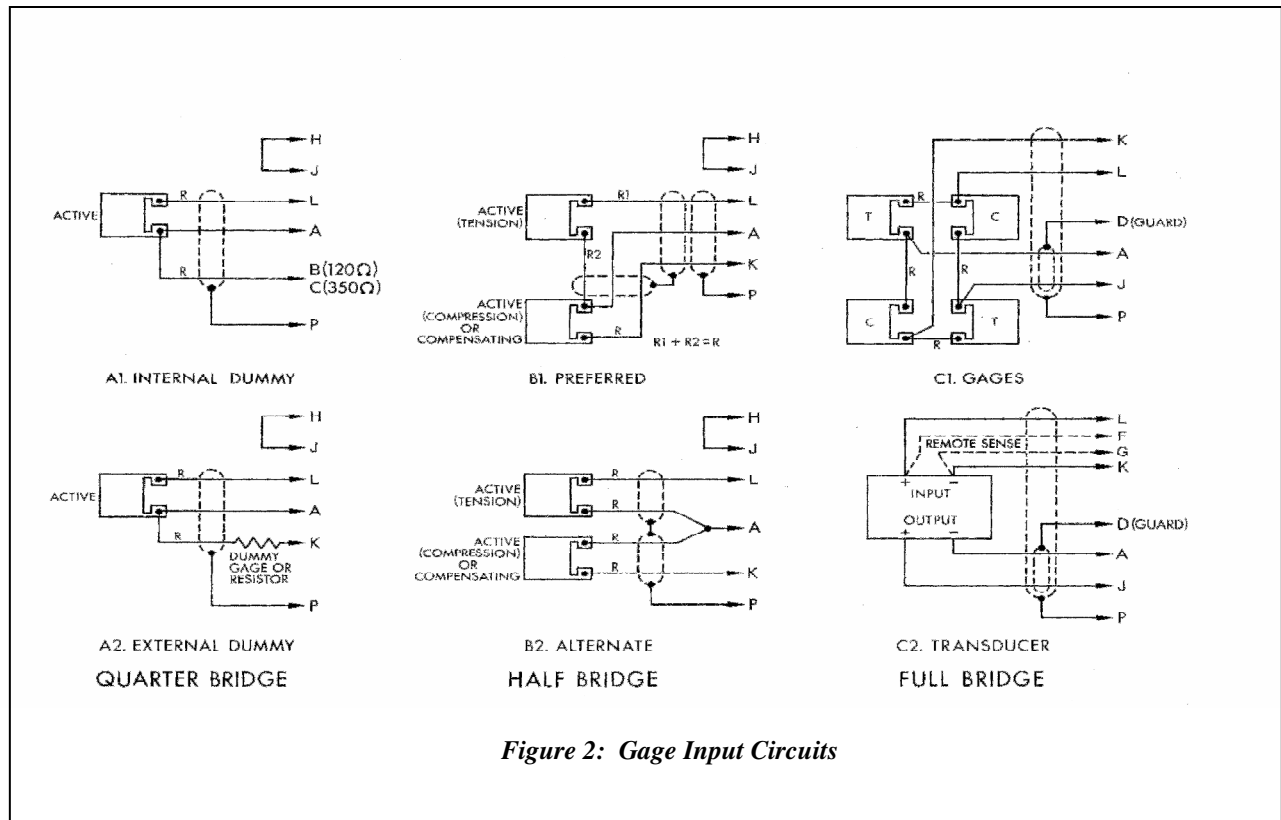

Figure 2: Gage Input Circuits

4.3 MILLIVOLT INPUTS

The 2310B Amplifier can accept dc inputs, such as thermocouples, provided two requirements are observed:

- Neither input should exceed $\pm 10V$ from circuit common in normal operation; and must *never* exceed a peak voltage of $\pm 15V$; and
- The input circuit cannot be completely floating; there must be some external return to circuit common for both input leads. In the case of thermocouples welded to a nominally grounded structure, this return is usually adequate.

The user is also cautioned regarding two sources of possibly significant error:

- Each input (pins A and J) requires a bias current of approximately ± 40 nA maximum typical; this current will flow through the source impedance of each input (to circuit common) and may cause a measurable offset voltage.
- Any non-symmetry in the source impedances of the two inputs will somewhat reduce the CMR of the amplifier.

4.4 WIRING CONSIDERATIONS

In addition to the chassis ground available at pin P of the

INPUT plug, the 2310B has an active “guard”

connection available at pin D. This guard may be a more effective shield connection than chassis ground, but to be effective the shield must be left disconnected (and insulated against accidental groundings) at the gage end. Normally the guard shield is used inside a conventionally grounded shield, as shown in Figure 2C. Certain important considerations affect wiring technique, depending on whether the purpose of the test is to measure static or dynamic data.

4.4a Dynamic Data: It is extremely important to minimize the extent to which the gages and lead wires pick up electrical noise from the test environment; this noise is usually related to the 50 or 60 Hz line power in the test area:

- Always use twisted multi-conductor wire (*never* parallel conductor wire); shielded wire is greatly preferred, although it may prove unnecessary in some cases using short leads.
- Shields should be grounded at one (and only one) end; normally the shield is grounded at the INPUT plug and left *disconnected* (and insulated against accidental grounding) at the gage end. Do not use the shield as a conductor (that is, do not use coaxial cable as a two-conductor wire).
- The specimen or test structure (if metal) should be electrically connected to a good ground.
- Keep all wiring well clear of magnetic fields (shields do not protect against them) such as

transformers, motors, relays and heavy power wiring.

- e) With long leadwires, a completely symmetrical circuit will yield less noise. (A half bridge on or near the specimen will usually show less noise than a true quarter-bridge connection; a full bridge would be still better.)

4.4b Static Data: Precise symmetry in leadwire resistance is highly desirable to minimize the effects of changes in ambient temperature on these wires.

- a) In the quarter-bridge circuit, *always* use the three-leadwire circuit shown in Figure 2, rather than the more obvious two-leadwire circuit.
- b) Insofar as possible, group all leadwires to the same channel in a bundle to minimize temperature differentials between leads.

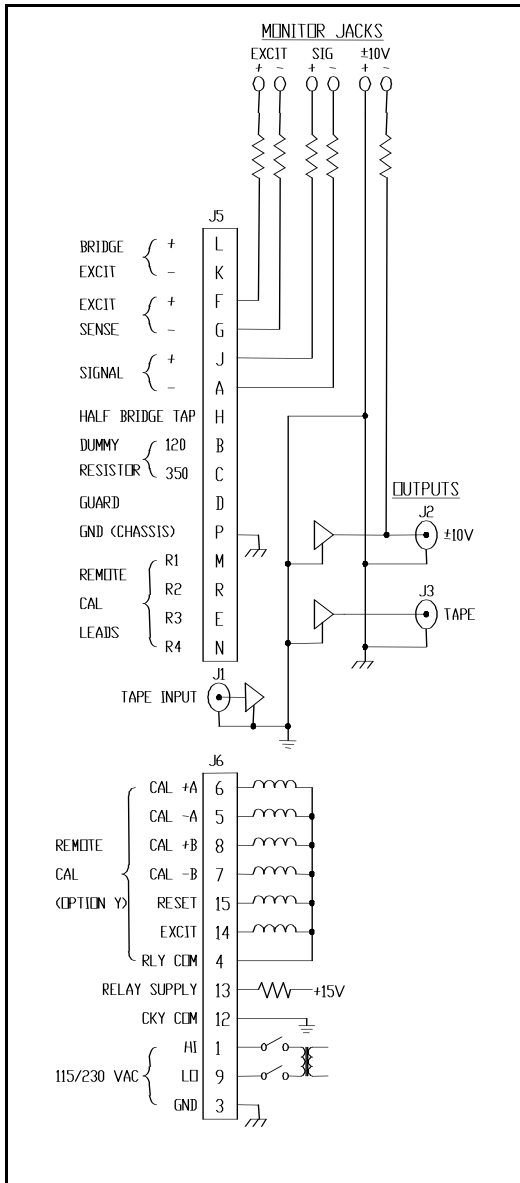

- c) If long leadwires are involved, calculate the leadwire desensitization caused by the lead resistance. If excessive in view of the data accuracy required, use the adjusted gage factor (see 5.3 *Shunt Calibration — Stress Analysis*), increase gage resistance, or increase wire size — or all three.

4.5 OUTPUT CONNECTIONS

CAUTION: During typical use of this instrument, shorted or open inputs as well as AUTO BAL circuit usage will often cause the $\pm 10V$ outputs to approach $\pm 15V$. (Tape output is limited to 2V.) The GALV output could deliver over 20 mA. If such levels can damage the output devices, it is important that proper precautions be taken. In those situations, it is suggested that external resistance be added to the output circuitry.

Normally the third prong on the power cord should establish an adequate chassis to earth ground connection. When connecting this system to the peripheral instruments, the user should be aware that having more than one system ground could cause noise-generating ground loops.

The 2310B Amplifier has two simultaneous non-interacting outputs; any one or all may be used in a particular test. Both outputs are accessible at the rear of the 2310B utilizing coaxial (BNC) connectors.

The “ $\pm 10V$ ” Output BNC would normally be connected to a scope, voltmeter, or multiplexer. Gain figures are direct reading to this output.

The $\pm 10V$ Output is also available at the MONITOR pin jacks on the front panel. A 10 K resistor is used internally to decouple any noise injection.

The TAPE Output (TAPE BNC) is normally used only for analog magnetic tape recorders. Full-scale amplifier output (10V at “ $\pm 10V$ ” Output) will be 1.414V at the TAPE Output, which is the customary full-scale input for tape recorders.

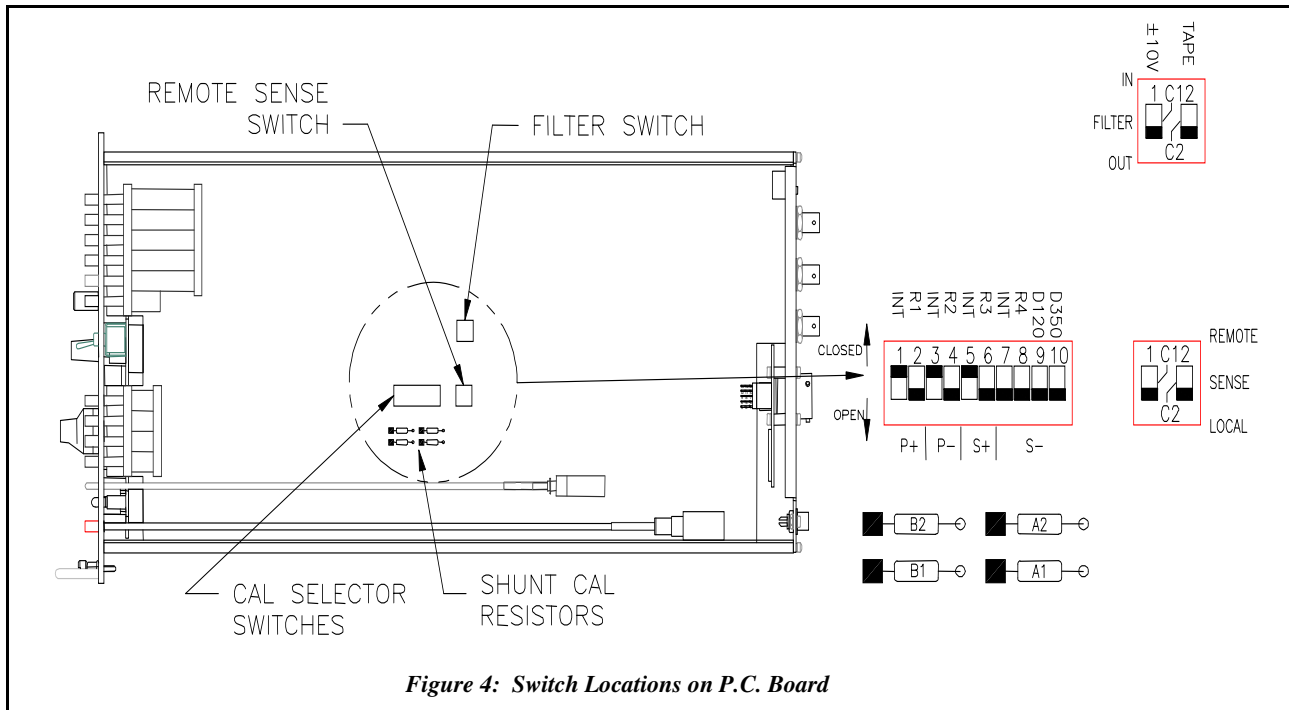

Figure 4: Switch Locations on P.C. Board

4.6 FILTER OUTPUT SELECTOR

The 2310B Amplifier has a selectable low-pass filter. This filter, controlled by front panel push buttons, can be set for one of several frequencies or at wide-band (“WB” button), in which case the filter is bypassed.

The filter can affect either one or both of the outputs. To select the outputs to be filtered, open the right side-cover of the 2310B and note the two toggles on the red FILTER switch (near the top of the p.c. board) marked ±10V, and TAPE; this switch is shown in Figure 4. Any toggles in the IN (up) position indicate that that output will be filtered when any FILTER button other than WB is depressed; outputs for which the toggle is in the OUT (down) position will still be operating at wide-band. Filter characteristics are discussed in 4.13 Filter.

4.8 EXCITATION

Select the desired bridge excitation with the EXCITATION selector switch.

In stress analysis, it is always desirable to use the highest excitation that the active gage can tolerate *under the test conditions*. Factors, which increase this, are high resistance (gage resistances of 350Ω or higher), long gage length and gage width and a good heat-sinking material (such as aluminum). Clearly, small 120Ω gages on plastic materials are to be avoided if in any way possible; even *very* modest excitations may be excessive. Note that most increments on the EXCITATION selector switch represent a voltage increase of about 40%, or a 100% increase in power to the gage.

When using commercial transducers, the manufacturer usually specifies the bridge excitation. If the transducer uses metallic (foil) gages, this is a maximum value; while any excitation up to the “maximum” could be

used, generally 50% to 75% of this maximum will yield improved transducer stability while retaining a good signal-to-noise ratio. However, when using transducers with *semi-conductor (piezoresistive)* gages, the *specified excitation should be used*, if possible, to achieve the advertised performance.

The bridge excitation supply in the 2310B is semifloating. Unless some ground exists in the input circuit, the supply automatically centers itself about circuit common (e.g., when set at 5B, P+ will read +2.5V above common). However, either P+ or P- may be intentionally grounded if desired (to minimize leads to a multi-channel system, for example) without affecting total bridge excitation. (Accidental grounds may cause errors, depending on where the ground occurs. This is because up to 0.75 mA will flow through the ground connection. Both P+ and P- are, in effect, returned to ground through 15 kΩ resistors.)

The accuracy of the EXCITATION selector is guaranteed to within ±1%. If for any reason the exact setting must be known, it can be measured at the EXCITATION MONITOR pin jacks on the front panel; the EXCITATION toggle switch must be ON to make this measurement.

Should the user desire to change the excitation voltage for any position on the EXCITATION selector switch, the resistor for that setting may be changed (it is located on the switch itself). The resistance required can be readily calculated:

$$R = 10,000 \times \frac{V}{18 - V} \quad (\text{Eq. 5})$$

where: R = required resistance in ohms
V = desired excitation in volts

4.9 AMPLIFIER BALANCE

With a strain gage or transducer connected to the INPUT, the EXCITATION switch still at OFF, and the X100 GAIN button depressed, both OUTPUT lamps at the top of the front panel should be completely dark. If not, turn the AMP BAL adjustment below the EXCITATION toggle switch (using a small screwdriver) to extinguish the lamps. (If the “-“ lamp is lit, turn clockwise, etc.)

NOTE: If the AMP BAL adjustment does not have any effect on the OUTPUT lamps, check that the PLAYBACK switch (on the rear panel) is at NORM (down).

If both lamps are lit at best null, this is an indication of excessive noise. This noise is frequently from the 50 or 60 Hz line; check shielding and the instrument ground. See **4.5 Output Connections**. Refer to **4.4 Wiring Considerations** for further discussion on shielding.

4.10 BRIDGE BALANCE

The input must, of course, be connected to balance this input. It is not necessary that the outputs be connected — in fact any device that could be damaged by a full-scale output should *not* be connected at this time.

Having selected the desired bridge excitation, turn the EXCITATION toggle switch to ON; one OUTPUT lamp will probably light fully.

Just below the OUTPUT lamps, momentarily press the AUTO BAL toggle switch all the way down to the RESET position, and release. In 1 to 3 seconds (8 seconds under the most extreme conditions) the OUTPUT lamps should extinguish, indicating balance. If, after several seconds, balance is not indicated, try again. (Occasionally a “spike” of noise from the environment will prematurely stop the balance operation.)

Occasionally the lamps will dim, but not go out; this means that the output is within 0.04V of balance, which is usually adequate, but not zero. For precise balance turn the vernier TRIM knob to extinguish the lamps. (In the presence of noise below 5 kHz, AUTO BAL will normally stop short of true balance; below 500 Hz the error is half the peak-to-peak noise amplitude.) High levels of input noise may make it impossible to extinguish the lamps (both lamps may remain lit). Special input wiring, shielding, and grounding techniques may be necessary to reduce the noise. Even though both lamps are not extinguished (due to the noisy environment), it may be possible to take accurate data (depending upon the test situation).

If, when balance is achieved, the yellow HI lamp is lit, this is an indication that the Automatic Bridge Balance circuit is operating in the high range: bridge unbalance is between 1% and 5% (5000 and 25 000 $\mu\epsilon$ at GF = 2), which would usually be considered very abnormal if quality gages and good installation and wiring practices were used. Before taking data it may be advisable to

explore the reason for this unbalance; possibly the gage should be replaced.

If the HI lamp constantly cycles on and off (4 seconds on, 4 seconds off), the unbalance at the input exceeds 5%, probably due to a gross fault or wiring error (or EXCITATION is not ON or the PLAYBACK switch is at ON).

Possible faults:

“+” OUTPUT lamp lit: open gage, 350 Ω gage with 120 Ω dummy, or P+ lead open.

“-“ OUTPUT lamp lit: shorted gage, 120 Ω gage with 350 Ω dummy, or lead to D₁₂₀ (or D₃₅₀) open.

The automatic bridge balance circuit uses a ratio voltage-injection technique and is thus essentially independent of both EXCITATION and GAIN. However, if either is changed significantly and a precise balance is desired, AUTO BAL should be RESET after final setup. A significant change in the null when EXCITATION is *increased* one position indicates that the new excitation is probably excessive (causing self-heating in the gage) and should be returned to the lower position; a similar change as EXCITATION is *decreased* would indicate that the higher setting was probably excessive.

4.11 BATTERY TEST

The automatic bridge balance circuit stores the balance value digitally. The value will not be lost when POWER is turned off (or there is a failure in the ac mains) since the 2310B has a keep-alive supply (a small battery) to power this circuit at all times.

To check the condition of these batteries, ac POWER must be on. Then press the small BAT TEST button: the “+” OUTPUT lamp should light. If the “-“ OUTPUT lamp lights, the batteries are very low and should be replaced (see **7.3 Battery Replacement**); furthermore, instrument POWER should be left on at all times if retention of bridge balance is desired.

Battery drain to the circuit is insignificant (less than 0.1 mA-Hr/yr) so theoretical life is several decades. But any battery will self-discharge and should be routinely replaced every year or two.

4.12 GAIN

The GAIN controls on the 2310B Amplifier are direct reading. The 10-turn control may be set anywhere between 1.000 and 11.000. This setting is then multiplied when the push button is depressed (X1, X10, etc.). Thus any gain between 1 and 11 000 can be preset.

There is some overlap between ranges. For best accuracy, a gain of 1000 should be achieved with the dial at 10.000 and the X100 multiplier depressed, rather than 1.000 and X1000.

The user must be aware that “system gain” is the product of bridge excitation and amplifier gain. It is always desirable to operate at high bridge excitation and

thus minimize amplifier gain — and consequently minimize the amplification of the small noise always present. But there are constraints on the maximum permissible excitation (see **4.8 Excitation**), so amplifier gain becomes the dependent variable.

In stress analysis, if the desired output sensitivity is known, amplifier gain can be calculated:

$$V_{OUT} = V_{BR} \times A \times \frac{K}{4} \times \mu\epsilon \times 10^{-6} \quad (\text{Eq. 6})$$

where: V_{OUT} = amplifier output in volts
(at $\pm 10V$ Output)

V_{BR} = bridge excitation in volts

A = amplifier gain

K = gage factor of the strain gage

$\mu\epsilon$ = strain in microstrain
(microinches/inch)

Note that this equation assumes *one active gage*; additional active gages will increase the output.

Equation 6 can be rearranged as:

$$A = \frac{1}{V_{BR}} \times \frac{4}{K} \times \frac{V_{OUT}}{\mu\epsilon} \times 10^6 \quad (\text{Eq. 7})$$

The term $V_{OUT}/\mu\epsilon$ can be interpreted as system sensitivity in volts/microstrain, or V_{OUT} can be amplifier full scale (10V) and $\mu\epsilon$ the total strain to achieve full-scale output.

Using commercial transducers, where the full-scale output sensitivity is usually known (typically 2 mV output per volt of excitation), the output equation is very simple:

$$V_{OUT FS} = V_{BR} \times A \times k \times 10^{-3} \quad (\text{Eq. 8})$$

where: $V_{OUT FS}$ = amplifier output at full-scale
transducer input

k = transducer sensitivity in mV/V

Rearranging Equation 8:

$$A = \frac{V_{OUT FS}}{V_{BR} \times k} \times 10^3 \quad (\text{Eq. 9})$$

Shunt calibration is a very standard alternate technique for establishing amplifier gain, especially for stress analysis. It is a powerful method, when done correctly, since it compensates for any error in bridge excitation, amplifier gain, and the sensitivity of the external indicator or recorder; in some arrangements it even compensates for potential errors caused by the resistance of the wiring to the gages, even when that resistance is unknown.

While simple in concept, there are so many subtleties, alternate circuits available in the 2310B, and equations, that the user is referred to in **5.0 Shunt Calibration** of this manual, which is devoted exclusively to this topic.

When using transducers, it is often most accurate and convenient to simply apply a known input (force, torque, pressure, etc.) and adjust GAIN to achieve the desired output. If this physical input is less than the full-scale rated input to the transducer, be careful that the amplifier (or recorder) will not limit or saturate with a full-scale input.

4.13 FILTER

The standard 2310B is equipped with a 6-pole low-pass active filter which, depending on which FILTER button is depressed on the front panel, will heavily suppress noise and signal components above the selected frequency: 10 Hz, 100 Hz, 1 kHz or 10 kHz. The gray button (marked WB) eliminates the filter so that the amplifier is operating at its full bandpass (“wide-band”). The marked frequencies are the frequencies at which the output is suppressed 3 dB (down 30% from normal), in accordance with standard instrumentation practice.

The filter can affect either one or both of the two outputs. The switch to select outputs is mounted on the internal p.c. board; it is more fully described in **4.7 Filter Output Selector**.

The characteristic of the active filter is a modified Butterworth transfer function (see Figure 8A). This characteristic achieves a fairly sharp transition at the set frequency and is thus generally most satisfactory where most signal components approximate sine waves. However, should there be an abrupt step input (as with impact tests), the user is cautioned that the Butterworth filter has moderate overshoot (approximately 8% with 6 poles) and it may be desirable to observe the signal in the wide-band mode, thus avoiding the filter distortion. See **6.0 Active Filter** for further discussion of filters.

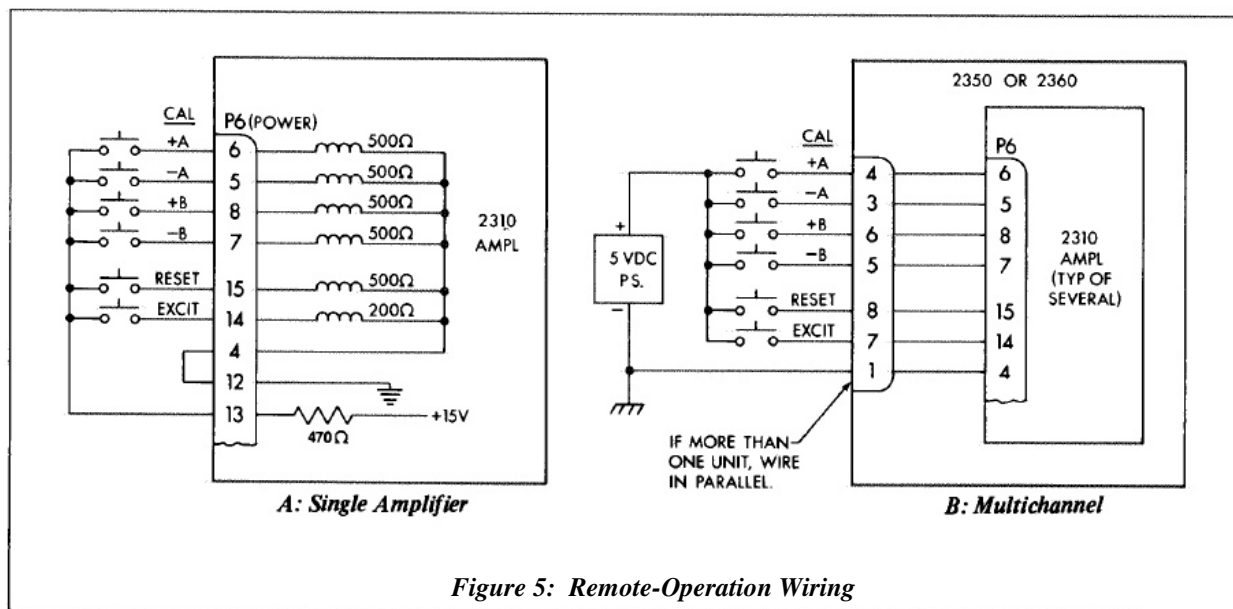

Figure 5: Remote-Operation Wiring

4.14 DYNAMIC TESTING

Occasionally the only data of interest is the peak-to-peak amplitude of dynamic signals or the frequency or shape of the dynamic component, and it may be desirable to suppress the static component.

To observe purely dynamic signal components, press the white AC button (below the FILTER buttons). This is an alternate-action push button: in the “in” position all signals are ac-coupled (after the preamp); in the “out” position all signals are dc-coupled. The coupling constant suppresses 5 Hz signals approximately 5% (the -3 dB frequency is about 1.7 Hz).

NOTE: The automatic and trim balance controls will not affect the dc output level in the ac-coupled mode.

The preamplifier remains dc-coupled at all times to maintain good common-mode rejection. Even when ac coupling is selected, there is a maximum permissible differential dc input which must not be exceeded (to avoid saturation of the preamplifier); this limit is a function of the GAIN push button selected:

GAIN Button	Max DC Diff. Input
X1	±10 V
X10	±1 V
X100 or X1000	±0.1 V

It is recommended that bridge unbalance be held within 5% (25 000 μe @ GF=2) when possible; the Automatic Bridge Balance circuit is still operable and will compensate entirely for this much unbalance. (With the EXCITATION toggle switch ON, simply press AUTO BAL to RESET momentarily.) Should the bridge unbalance exceed 5%, AUTO BAL must be OFF (all the way up) and the selection of GAIN button and EXCITATION must be made very carefully so as not to exceed the limits tabulated above.

4.15 TAPE PLAYBACK

The 2310B Amplifier can be used to re-examine data previously recorded on magnetic tape. A suggested practice is to originally record the data with no filter on the TAPE output (TAPE FILTER selector toggle on the p.c. board set at OUT); the recorded tape thus contains all possible frequency components from the test. Even if the data were simultaneously observed and/or recorded on an oscillograph, with or without filtering, the tape-recorded data would still be wide-band.

At some later date the tape-recorded data can be played back through the 2310B and re-examined (using a scope or recording oscillograph); since the active filter in the 2310B is operable in this playback mode, any filter frequency (or WB) may be selected. Note that both outputs are available.

To use the playback mode, move the PLAYBACK switch on the rear panel of the 2310B to ON (up). Connect the output from the tape recorder to the INPUT BNC connector near the top of the rear panel (full-scale input is ±1.414V or 1 Vrms for a sine wave). Outputs (±10V and TAPE) appear at their normal connectors.

The only controls on the front panel that are operable in the playback mode are FILTER buttons (10 to 10K and WB).

After using the playback mode, do not forget to return the PLAYBACK switch to NORM! Otherwise, the normal signal presented to the INPUT connector will have no effect on the Outputs.

4.16 REMOTE-OPERATION RELAYS (Option Y)

Six isolated relays can be provided to operate the following functions in the 2310B. See Figure 8.

Shunt CALibration (+A, -A, +B, and -B)
Auto Balance RESET
Bridge EXCITation on/off (to check amplifier balance)

While the relays are not installed unless Option Y is specified at time of order, they can be easily installed later by a qualified technician; all wiring already exists in the 2310B Amplifier. Each relay requires 5 Vdc (10 mA each, except 25 mA for the bridge excitation relay). For after-sale installation, order one Relay Kit 120-001191 for each 2310B Amplifier.

To control the relays in a *single* 2310B Amplifier the internal +15V supply may be used, as shown in Figure 8A. When more than one 2310B is to be operated with a single set of switches (or external relays), an external 5 Vdc power supply is required (250 mA for each 10 channels). Option Y must also be specified for the 2350 Rack Adapter or 2360 Portable Enclosure. (For after-sale installation, order one Cal Kit 120-001192 for each 2350 Rack Adapter, or Cal Kit 120-001193 for the 2360 Portable Enclosure.) The system would then be wired as in Figure 5B.

In order to remotely initiate an automatic bridge balance, the RESET line must first be active for a minimum of 50 milliseconds and *then* released. (The balance process *starts* after the voltage is released.) To remotely turn *off* the bridge excitation, the EXCITation off line must be made active (5 Vdc). The other functions (CALibration) are turned *on* when 5 Vdc is supplied to the appropriate pin and turned *off* when the voltage is removed.

4.17 QUARTER-BRIDGE NONLINEARITY

The output of a Wheatstone bridge is somewhat nonlinear with only one active arm. This nonlinearity is usually insignificant in stress analysis (percent error equals percent strain @ $GF=2$). Should high strains be encountered (post-yield studies or tests on some non-metallics), the error can be removed during data reduction, although the user is cautioned regarding uncertainty of the value of gage factor above 1% strain.

If it is desired to obtain an output which is linear with ΔR in one arm of a bridge, this can be achieved with the 2310B.

This technique utilizes the remote-sense leads to maintain constant voltage across a dummy resistor, and therefore constant *current* through this resistor and through the active arm. Connections to the INPUT plug are as follows:

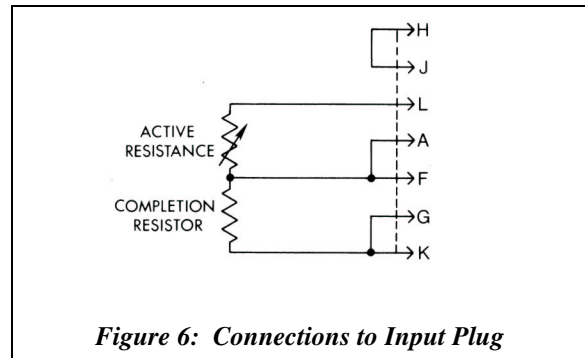

Figure 6: Connections to Input Plug

Two changes to the operating procedure are required:

- The Remote SENSE switch on the p.c. board must be at REMOTE, and
- The EXCITATION selector switch must be set at *half* the desired bridge excitation.

The user may notice that bridge balance is somewhat affected by this circuit (e.g., 0.5% with a 500 Ω half bridge), but this is well within the range of the Automatic Bridge Balance circuit. (The source of this shift is the presence of R34 — 100 k Ω — across the active resistance.)

5.0 SHUNT CALIBRATION

5.1 INTRODUCTION

Shunt calibration is a very powerful technique to determine total system “gain” in Wheatstone bridge systems such as the 2310B. In general, one arm of the input bridge is shunted with a specific resistance, which introduces a specific $-\Delta R$ into this arm (simulating a compressive strain in a strain gage). The amplifier output will respond exactly as if that specific $-\Delta R$ (i.e., strain) actually had occurred with the existing bridge excitation and amplifier gain. It is only necessary to calculate the simulated strain and read the amplifier output to determine the *system* sensitivity.

IMPORTANT: It should be emphasized that the intent of shunt calibration is to determine the performance of the *circuit and instrument* into which the gage is wired; in no way does it verify the ability of *the gage* itself to measure strain nor the characteristics of its performance.

While the basic shunt calibration concept and equations are simple and well-known, the presence of leadwire resistance can have *very* significant effects on the accuracy of the technique. Either the precise shunt circuit used must be chosen such that the leadwire resistance has no net effect, or a correction must be made for this effect.

The shunt calibration circuits available in the 2310B are designed to be exceptionally versatile and easy to change. Most circuits apply specifically to stress analysis application; when using commercial strain gage transducers the double-shunt method is suggested (**5.4 Transducers**).

5.2 SHUNT CALIBRATION COMPONENTS IN 2310B

The two CAL switches on the front panel normally provide two independent values (A and B) of simulated strain, each of which can be either + or -. (If both switches are operated simultaneously the values are algebraically additive.)

With Option Y additional relays are installed in the 2310B such that any of these four switch positions can be operated remotely [**4.16 Remote Operation Relay (Option Y)**].

Four calibration resistors, two associated with the “A” switch and two with the “B” switch, are installed in the miniature sockets on the right side of the p.c. board (see Figure 4). These resistors may be changed in the field to suit specific test requirements. See **5.5 Standard Calibration Resistors**.

A blue ten-switch Calibration Circuit Selector is installed on the right side of the p.c. board (see Figure 4). Only two or three (or four for transducers) should ever be closed (up) for any given circuit.

Note that the switches are divided into four groups, as marked at the bottom: P+, P-, S+, and S-, corresponding to the four corners of the bridge. Each group has an “INT” switch, which connects the calibration circuit to the indicated corner of the bridge *internal* to the 2310B; and an “R” switch, which connects the circuit to a dedicated pin in the INPUT connector — to be used when shunting a *remote* active gage. The S- group has two additional switches for shunting the internal dummy gages (D120 and D350).

5.3 SHUNT CALIBRATION — STRESS ANALYSIS

Shunt calibration can be achieved by shunting any one of the four arms of the input bridge — this includes the active gage and the bridge completion arms in the 2310B. The same equation applies, but note the definition of R_a :

$$\mu\epsilon_{cal} = \frac{R_a}{K'(R_{cal} + R_a)} \times 10^6 \quad (\text{Eq. 10})$$

where: $\mu\epsilon_{cal}$ = strain simulated (microstrain)
 R_a = resistance of leg shunted (ohms)
 K' = effective gage factor of active gage
 R_{cal} = resistance of calibration resistor (ohms)

R_a may not be equal to the resistance of the active gage when the shunt is across one arm of the dummy half bridge. (But also note that no correction factor is ever necessary for the shunting effect of the resistance balance circuit, since the 2310B does not use the shunt method for bridge balance.)

Gage factor (K') in equation 10 may be the actual package gage factor of the active strain gage (corrected for temperature, when necessary), or it may be a value adjusted for leadwire desensitization:

$$K' = K \times \frac{R_g}{R_g + R_l} \quad (\text{Eq. 11})$$

where: K = gage factor of active gage
 R_g = resistance of active gage (ohms)
 R_l = resistance of leadwire(s) in series with active gage (usually the resistance of *one* leadwire) (ohms)

The specific gage factor correction applicable to the various circuits is indicated in Chart 1.

Chart 1 tabulates the recommended shunt calibration circuits available in the 2310B, together with the switch settings and wiring necessary to achieve them.

The calibration resistor value (calculated from Equation 10) would apply to CAL Switch A if the resistor is installed at position A1 or A2, or it would apply to CAL Switch B if installed at position B1 or B2; CAL A and CAL B are totally independent. Provided that the Calibration Selector Switches are set as specified in the chart, resistors installed at positions not called for have no effect on the output; it is not necessary to remove them.

<p>CKT 1: Shunt Internal Half Bridge</p> 	<p>Excitation SENSE: LOCAL Cal Selector Switches: #1 closed (P+ at INT) #3 closed (P- at INT) #5 closed (S+ at INT) Others open (down) $R_a = 350\Omega$ $K' = \text{from Equation 11}$</p>	<p>USE: Quarter and half bridge (full bridge with reduced accuracy).</p> <p>ADVANTAGES: Same resistors for any active gage resistance. No special wiring. + and - cal.</p> <p>DISADVANTAGES: Must correct for leadwire resistance.</p>
<p>CKT 2: Shunt Dummy Resistor</p> 	<p>Excitation SENSE: LOCAL Cal Selector Switches: #3 closed (P- at INT) #9 closed for 120Ω gage Or #10 closed for 350Ω gage (S- at D120 or D350) Others open (down) $R_a = \text{nominal gage resistance}$ $K' = K$ (Note: If cal Selector #1 is also closed, can also simulate compression, but for compression, K' must be from Eq. 11).</p>	<p>USE: True quarter bridge.</p> <p>ADVANTAGES: Automatically corrects for leadwire resistance when using 3-wire circuit. No special wiring. Accuracy independent of precise gage resistance.</p> <p>DISADVANTAGES: Useable only if internal dummy gages are in use. Simulates tension only.</p>
<p>CKT 3: Shunt Active Gage</p> 	<p>Excitation SENSE: LOCAL Cal Selector Switches: #2 closed (P+ to R1) #8 closed (S- to R4) Others open (down) $R_a = \text{gage resistance}$ $K' = K$</p>	<p>USE: Quarter, half, full bridge.</p> <p>ADVANTAGES: Classic theory using any leadwire method for bridge wiring.</p> <p>DISADVANTAGES: Two added wires necessary. Simulates compression only.</p>
<p>CKT 4: Shunt Active Half Bridge</p> 	<p>Excitation SENSE: LOCAL Cal Selector Switches: #2 closed (P+ to R1) #4 closed (P- to R2) #8 closed (S- to R4) Others open (down) $R_a = \text{gage resistance}$ $K' \cong K$</p>	<p>USE: Half or full bridge.</p> <p>ADVANTAGES: Classic theory using any leadwire method (except resistance between active gages but be negligible). Simulates + and -.</p> <p>DISADVANTAGES: Three added wires necessary.</p>

Chart 1: Stress Analysis Shunt Calibration Circuits

Many other arrangements are possible, but they must be used with great care. For example, the obvious method to shunt an active gage (quarter or half bridge) would be simply to close the Calibration Selector Switches for P+, P- and S- to INT, achieving a circuit functionally similar to Circuit 4. However, the effect of leadwire resistance is surprisingly high (some *four times greater than expected* from Equation 11), so the circuit should never be used; much more accurate results will be achieved in these cases with Circuit 1 (or especially Circuit 2, if using a true quarter bridge).

5.4 TRANSDUCERS

The term transducer in the context of a bridge conditioner can include any full bridge composed of strain gages with a known calibration. It may be simply four gages properly located on a part to measure force or torque (frequently a detail part of the mechanism under study), or it may be a more elaborate (and accurate) commercial transducer.

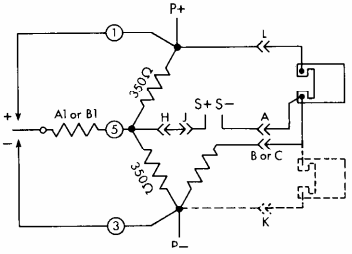
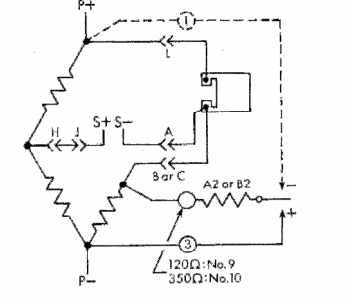
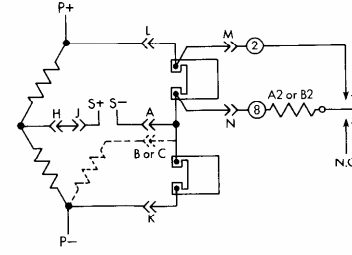
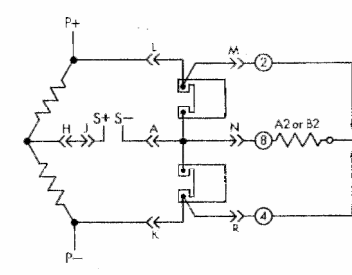
Commercial transducers are much more complex circuits since they typically have a number of additional resistive elements to correct for the effects of temperature to achieve the desired precise span calibration. Nonetheless, this complexity can usually be overlooked without greatly compromising the accuracy of shunt calibration, if done properly.

Shunt Calibration per Calibration Certificate:

Many transducer manufacturers provide shunt calibration information as part of the calibration certificate. When available, this is the most reliable method of calibration, but the specified resistance must be connected *precisely as indicated by the manufacturer*. Sometimes there are two separate pins dedicated to shunt calibration; additional leads are required to accomplish calibration with resistors installed inside the 2310B. In other cases the pins may be one normal input lead and one normal output lead. Since the effects of leadwire resistance are very measurable, additional leads dedicated to the shunt calibration circuit must be used between the transducer connector and the INPUT connector to the

2310B.

The complete schematic of the available connections for shunt calibration of transducers is shown in Figure 7.

As an example of transducer shunt calibration, assume that the certificate for the transducer specifies that a 10 kΩ resistor should be placed between the positive excitation (P+) pin and the negative output (S-) pin. A suggested method with the 2310B would be:

- a) Install a 10 kΩ resistor in position "A2" on the p.c. board.
- b) In addition to the normal 4-wire connection to the transducer (6-wire if remote excitation sense is used), connect two additional wires; one from the positive excitation pin *on the transducer* to pin M of the 2310B INPUT plug, the other from the *transducer* negative output pin to pin N of the 2310B INPUT plug.
- c) Inside the 2310B, Calibration Selector Switches 2 and 8 should be ON (all others open, or down).

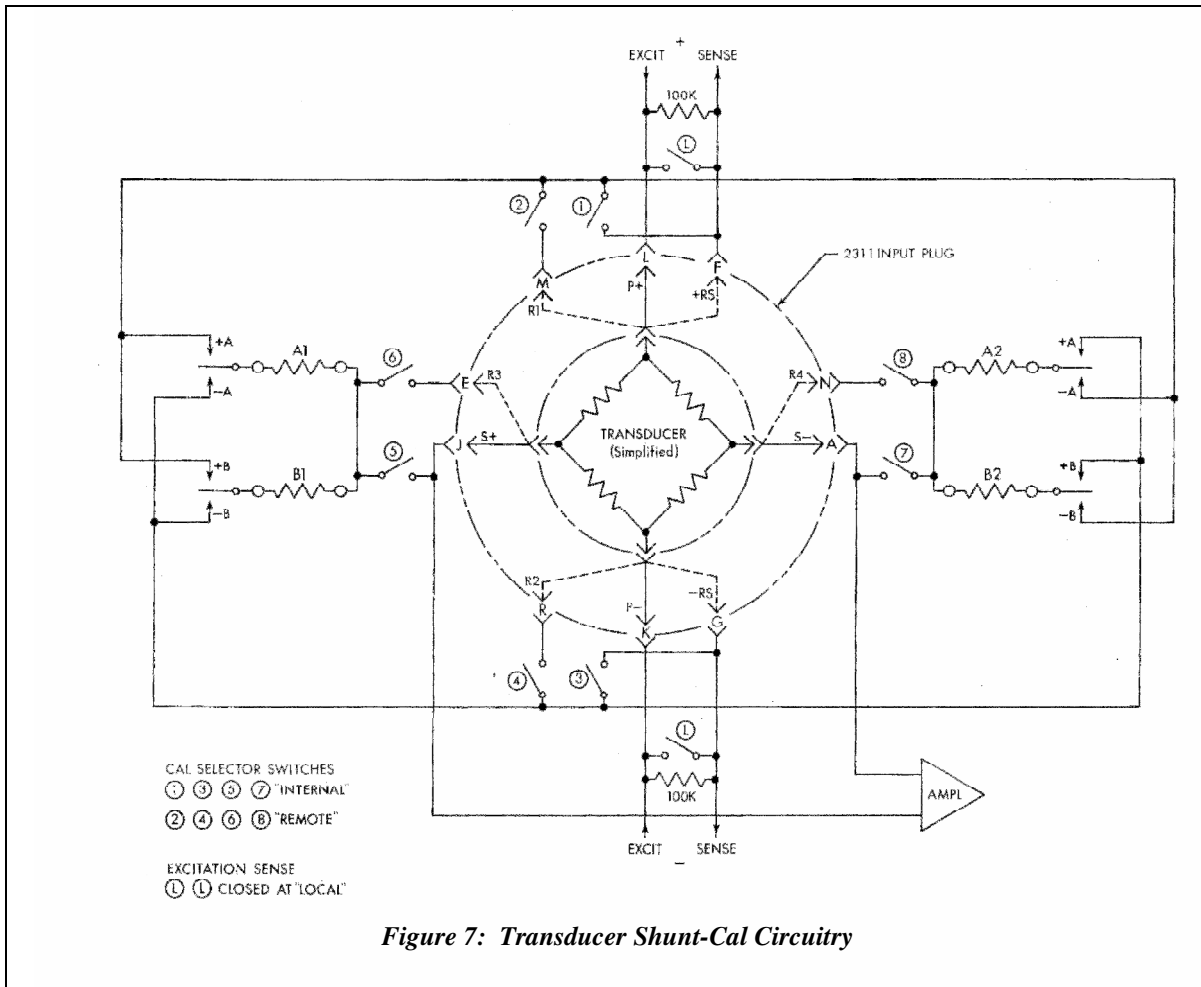

Figure 7: Transducer Shunt-Cal Circuitry

Excitation SENSE would be at LOCAL, unless the basic 6-wire system is in use, in which case it would be at REMOTE.

- d) To insert the 10 kΩ shunt, move the CAL A toggle (on the front panel) to “-“.

If shunt calibration data is not known, the best procedure is to calculate values to be used in double-shunt calibration; this procedure corrects for any normal nonsymmetry in the transducer by simultaneously shunting two opposite legs of the bridge. To calculate the resistor value, use the following equation:

$$R_{double-shunt} = R_0 \left(\frac{500}{k} - 0.5 \right) \quad (\text{Eq.12})$$

where: $R_{double-shunt}$ = value of each shunt resistor (ohms)
 R_0 = output resistance of transducer (usually 350 ohms)
 K = output to be simulated (mV/V)

Common values would be as follows for a 350Ω transducer:

MV/V	Ohms (double-shunt)
3	58,158
2	87,325
1.5	116,492
1	174,825

The above resistors must be placed electrically *at the transducer connector* (rather than the 2310B INPUT plug) to eliminate the sizable effect of leadwire resistance. To achieve this, four “remote-calibration” pins (E, M, N and R) are provided in the input plug, as shown in Figure 7.

The resistors (value as calculated in Equation 12) would be soldered to the p.c. board turrets in positions A1 and A2 (or B1 and B2). Now the selected transducer output, either + or -, can be simulated simply by operating the CAL A (or CAL B) front panel switch.

A common arrangement may be to calculate two resistor values (representing perhaps 100% transducer output and 25% output), putting one pair at A1 and A2, the other pair at B1 and B2; now either 100% or 25% of full output can be simulated by using either CAL A or CAL B.

It is important to emphasize that when using semiconductor (piezoresistive) transducers, EXCITATION must be set at the manufacturer’s specified voltage to achieve proper calibration. Transducers using foil gages may be excited with any voltage below the maximum value specified by the manufacturer, although best overall system performance will usually be achieved with 50% to 75% of the permissible maximum.

5.5 STANDARD CALIBRATION RESISTORS

The 2310B is intended to be ready for use as received, with bridge completion resistors, dummy gages and shunt calibration resistors installed. The standard shunt calibration resistors have been selected for maximum flexibility for stress analysis. These resistors are as follows:

A1	—	874.8k	±0.1%
A2	—	59.94k	±0.1%
B1	—	174.8k	±0.1%
B2	—	174.8k	±0.1%

These values provide the following shunt calibration levels (for identification of Cal Selector Switches, see Figure 4):

Input Circuit	Arm Shunted	Cal Selector Switches On	Strain Simulated @ GF=2
¼ & ½ bridge, 350Ω full bridge	Dummy half bridge	1, 3, 5	±A = ±200με ±B = ±1000με
120Ω ¼ bridge	Dummy resistor	3, 9	+A = +1000με
350Ω ¼ bridge	Dummy resistor	3, 10	+B = +1000με
350Ω transducer (double-shunt)	All	1, 3, 5, 7	±B = ±1 mV/V*

*These values assume zero leadwire resistance.

6.0 ACTIVE FILTER

6.1 FILTER CHARACTERISTICS

- a) The standard 2310B is supplied with an active 6-pole filter with Butterworth characteristics having high-frequency cut-off at the following frequencies: 10, 100, 1000 and 10 000 Hz.

- b) While both filters (with equal poles) ultimately reach the same slope at high frequencies, the sharpness of the Butterworth filter at F_{CO} results in better attenuation at any given high frequency.
- c) Should there be an instantaneous step input, the Butterworth filter will produce 5 to 8% overshoot (assuming precise component values), whereas the Bessel filter has no overshoot.

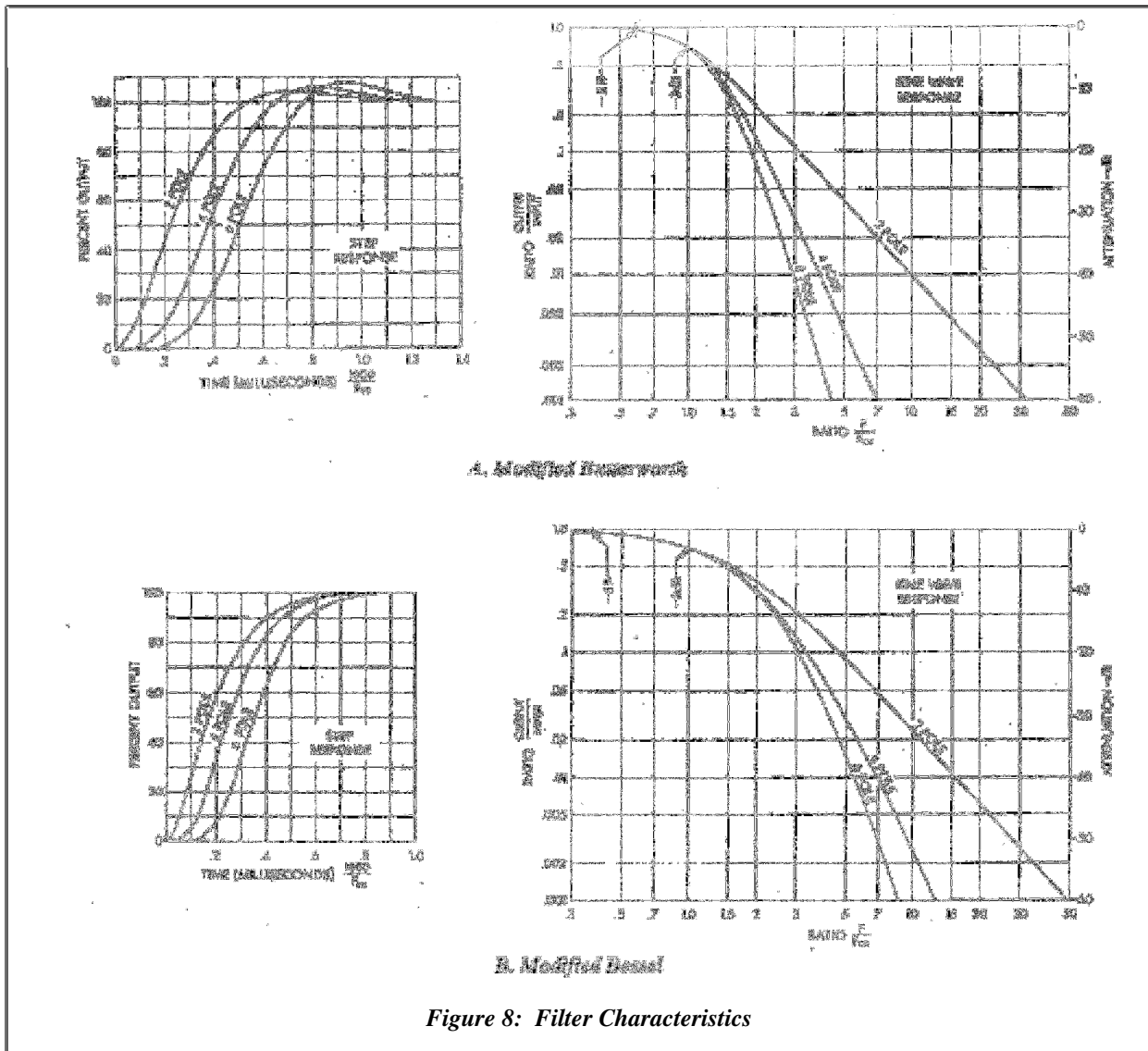

This section describes filter characteristics as relates to the 2310B.

The choice of filter characteristic (Butterworth or Bessel) is a compromise. With reference to Figure 8, note the following:

- a) The Butterworth filter falls off much more sharply around the -3dB frequency (F_{CO} in the curves).

Thus the choice of characteristic is very dependent on the type of testing performed. However, the Butterworth, with its sharper cut-off, is generally preferred.

When high noise rejection is required near F_{CO} , a filter with 6 poles is highly desirable. Although, note from Figure 8 that there is no discernible improvement below F_{CO} as the number of poles is increased.

The rise time (10% to 90%) for step inputs is virtually fixed; it is independent of both filter characteristic and number of poles:

$$\text{Rise Time} \cong \frac{0.35}{F_{CO}} \text{ in seconds} \quad (\text{Eq.13})$$

where: F_{CO} is the cut-off frequency (-3dB) in Hz.

All multipole filters introduce a significant time delay near and above the cut-off frequency. In multi-channel dynamic studies where instantaneous outputs from several channels are to be compared or analyzed at a specific point in time (for example, reduction of a 3-element strain gage rosette), these three channels must have identical filters to avoid "data skew" caused by different time delays in the three channels.

7.0 MAINTENANCE

Maintenance is to be done *only* by qualified technicians.

7.1 ADJUSTMENTS

To assist in maintenance, the following the diagram is provided to indicate the position of the IC and adjustments that are used to calibrate the 2310B. Also shown are the relays used for shunt cal and zero functions. Schematic diagrams are available to those who wish to gain a more detailed understanding of circuit operations and for organizations that choose to do their own repairs and adjustments. Our Applications Engineering Department can provide these diagrams, upon request, in paper and/or electronic formats.

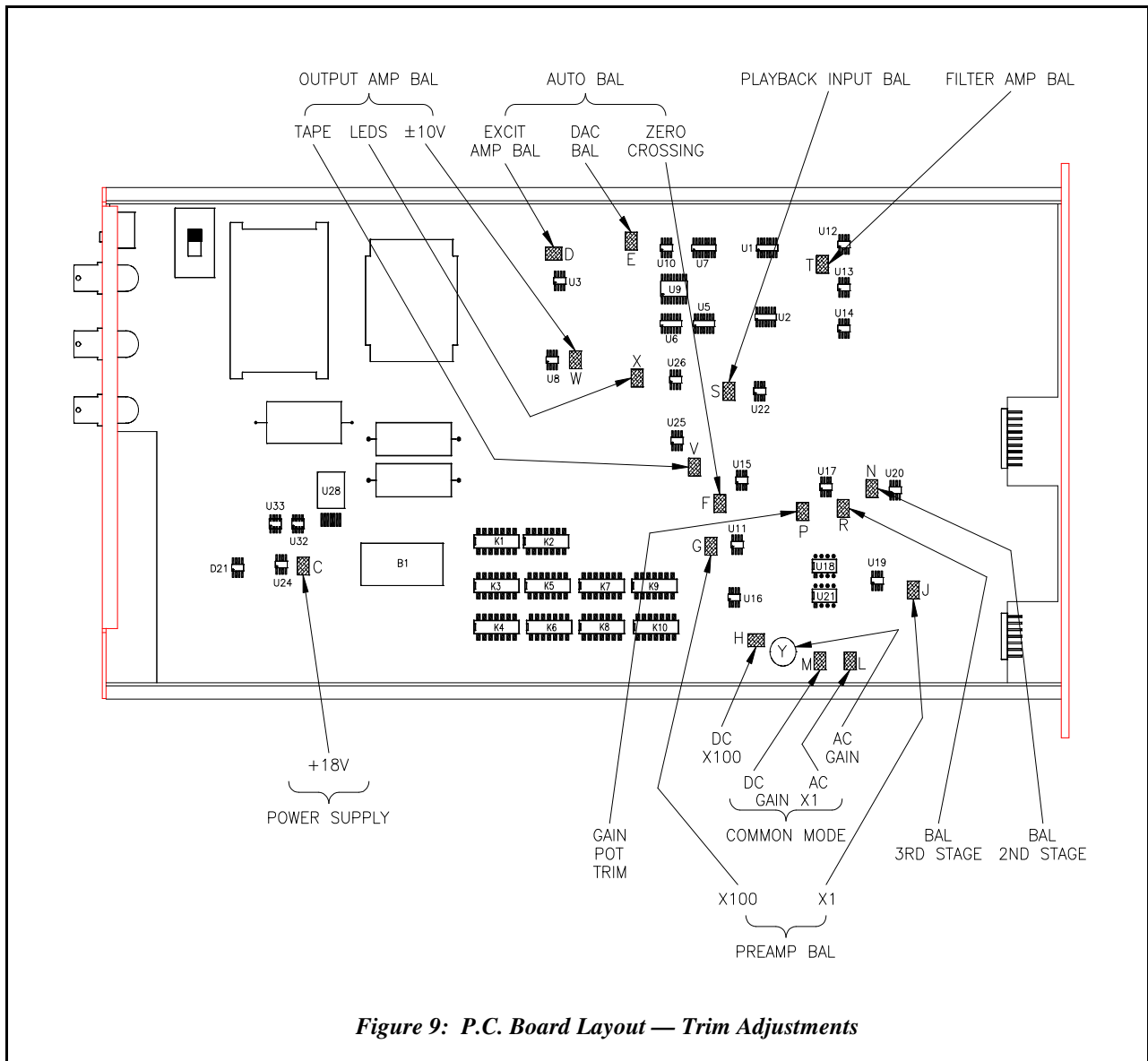

Figure 9: P.C. Board Layout — Trim Adjustments

There are a number of trim adjustments on the p.c. board; no adjustment of these controls should be necessary unless a component is changed, principally one of the integrated circuits. Each trim control is marked on the p.c. board with a letter of the alphabet to assist the technician. Additionally, many test points are marked on the component side of the board. Figure 9 shows the location of the various adjustments.

The 2310B must have ac power during servicing (see **4.1 Setup and AC Power**); accessory power cord 120-001196 is suggested.

The trim adjustments fall into three general categories: power supply checks and set points, common-mode adjustment, and balance adjustments for most operational amplifiers.

The bridge power supply reference can be set with or without an input to the 2310B, using a digital voltmeter. It is should be set 0.1% (if possible) after 15 minutes warmup.

METER LEADS	READING	ADJUST
- +		
TP16*	TP 5 +15.00V±0.5V	NA
TP16*	TP 17 -15.00V±0.5V	NA
P-	TP18 +18.00V±0.5V	NA
P-	TP19 +15.00V±0.01V	C

*TP16 is the same as chassis or common.

The amplifier balance controls should be set in the sequence listed at right, after the instrument has been warmed up for at least 15 minutes. The inputs must be shorted together and grounded by connecting INPUT plug pins A, J and P together. All readings should be made with a digital voltmeter or stable dc scope with a resolution of at least 1 mV; when possible set balances to within 0.2 mV of zero. All readings are relative to circuit common (OUTPUT pin 1). The front panel AMP BAL trimmer must be approximately centered (11 turns from one end), EXCITATION at OFF, and AC coupling button “out” (for dc coupling). Also, the front panel settings listed at right must be made prior to adjustment and not changed unless subsequently directed to do so.

Auto Balance adjustments should be made with a 350Ω bridge connected to the input; it should be possible to unbalance this bridge randomly up to about 3% unbalance.

METER LEAD	FRONT PANEL	ADJUST MENT	IC BALANCED
TP1	GAIN button X100	G	U16, U18, U21
TP1	GAIN button X1	J	U19
TP1	GAIN button X1000	G	U16, U18, U21
TP2	—	N	U20
TP2	AC button “IN”	*	U20
TP3	GAIN button X1 and dial 11.000	R	U17
TP4	GAIN dial 11.000 FILTER 100	T	U12, U13, U14
TP6	FILTER WB	V	U25
TP7	—	W	U8
TP8	—	X	U26

*Press AC button IN, reading shift <5mV

Adjustments D and E are set to make the 2310B output (after “balancing” the bridge) independent of bridge excitation:

- Set GAIN at approximately X100; bridge outputs (amplifier inputs) shorted together.
- With EXCITATION at OFF, null LED’s with AMP BAL.
- EXCITATION ON, set at 15 V. Press RESET; use TRIM to extinguish LED’s.
- EXCITATION at 2 V; LED’s should stay out. If + LED lights, turn adjustment E clockwise to slightly light – LED, and vice versa.
- If an adjustment was required, repeat (c) and (d).
- Unbalance the input bridge approximately 3% (10K shunt across one 350Ω arm suggested) and remove short across bridge output.
- Follow steps (b) through (e), but trim adjustment D.

Adjustment F is set for best null (on average) using Auto Balance. The following procedure is suggested:

- Set GAIN at 500 and EXCITATION at 5 V.
- With EXCITATION at OFF, null LED’s with AMP BAL.
- With any random bridge unbalance, turn EXCITATION to ON and press RESET. If, at “balance”, the + LED is lit somewhat, turn adjustment F counter-clockwise (and vice versa) until both LED’s are extinguished at “balance”.

- d) Repeat above procedure with several random bridge unbalances to achieve best average performance. (If reading the $\pm 10V$ output with a DVM, readings at “balance” ideally should be between 0 and -3 mV, which is the theoretical resolution of the circuit at these settings.)

Adjustments H, L, M and Y (C31) all affect common-mode rejection in the preamplifier. They are most conveniently set using an audio oscillator (10 Hz to 5 kHz):

- a) Connect the oscillator between circuit ground and the two amplifier inputs (INPUT pins A and J) shorted together. Set the oscillator for about 10 Vp-p (3.5 Vrms).
- b) Connect oscilloscope to $\pm 10V$ (TP7) output, ac-coupled.
- c) Set GAIN dial at 1.000 and press X1 button.
- d) Set oscillator at 10 Hz; adjust M for best null on scope.
- e) Set oscillator at 1 kHz; adjust L for best null.
- f) Repeat (d) and (e) if adjustments were required.
- g) Press X100 GAIN button.
- h) Set oscillator at 10 Hz; adjust H for best null.
- i) Set oscillator at 1 kHz; adjust capacitor Y (C31) for best null.
- j) Repeat (h) and (i) if adjustments were required.
- k) If (h) and (i) required significant adjustment, repeat from (c) on.

7.2 BATTERY REPLACEMENT

The current drain from the keep-alive batteries in the automatic bridge balance circuit is continuous with POWER off, whether the instrument is plugged in or not, but this current is so small 5 to 10 nA that self-discharge (i.e., shelf-life) is far more significant.

The batteries should be replaced when the test circuit indicates low voltage (see **4.11 Battery Test**), or routinely two years after installation.

The batteries used in the 2310B are widely used and are available at most electronic supply stores. Eagle Picher PT-2150 (Lithium 3.6Volt, 1/2AA) or equal is recommended for a replacement. Any of the following silver oxide batteries may be used (two required):

To replace the battery:

- a) Disconnect power and remove cover on left side of the 2310B.
- b) Locate the battery holder near the rear of the 2310B.
- c) Note the orientation of the existing battery.

- d) Remove and properly dispose of the old battery in accordance with local codes.
- e) Install the new battery with the positive end (case of cell) toward the rear of the instrument, and the negative end toward the front.
- f) Replace 2310B side cover.
- g) Apply ac power to the 2310B and press BAT TEST; the + OUTPUT lamp should light.

7.3 COMPONENT REPLACEMENT

It is recommended that a defective 2310B be returned to Vishay Micro-Measurements for factory service, especially during the warranty period (to preserve the warranty); however, a qualified technician can often repair the unit in the field. Most electronic components used are standard commercially available items. Any component can be purchased from Vishay Micro-Measurements (if the Vishay Micro-Measurements part number is not listed below, please provide us with the component symbol and value — or an adequate description of the part — and the instrument serial number).

The following information may be of value for field service.

7.3a Resistors:

The 1% resistors are generally 100 ppm/ $^{\circ}C$, and 0.1% values are generally 25 ppm/ $^{\circ}C$.

All 0.05% and tighter tolerances are Vishay SMR1DR (2 ppm/ $^{\circ}C$) and must be ordered from Vishay Micro-Measurements.

Resistors R71 through R74 are part of the bridge completion assembly and must be ordered as part 200-131240.

7.3b Connectors

	Symbol	P/N
Input plug, 15-pin [Bendix PT06A-14-15P(SR)]	P5	12X300531
Mating power plug (not supplied) (ITT/Cannon DA15S or equal)	—	12X300151
Remote cal plug (for 2350/2360) (Cinch-Jones S-308-CCT)	—	12X300533
Line cord (for 2350 and 2360) (Belden 17742)	—	21X300126

7.3c Battery

Keep-alive supply (Eagle Picher PT-2150)	B1	23X500004 (1 required)
---	----	---------------------------

7.3d Toggle Switches

Filter selector (on p.c.b.) (Grayhill 76TC03)	SW1	10X900046
Excitation sense selector (on p.c.b.) (Grayhill 76TD01)	SW5	10X900047

Calibration selector (on p.c.b.) (CTS 206-10)	SW7	10X900048
Cal A and Cal B (C&K 7103P3D9V30QE)	S8, S9	10X600136
Auto Balance (C&K 7213PD9V38)	S10	10X600160
Excitation on/off (C&K 7201P3D9V30QE)	S12	10X600137

7.3e Relays

Calibration (CP Clare PRMA2A05)	K1, K2, K3, K4	11X500085
Remote cal & reset (CP Clare PRMA1A05)	K5, K7, K8, K9, K10	11X500078
Remote excitation on/off (Hamlin HE 721C0500)	K6	11X500077

7.4 FUSE REPLACEMENT

Fuse replacement is to be done only by qualified technicians with all cabling disconnected including the power cord. All fuses are rated at 250V and are appropriate for both 115V and 230V operation. Substituting non-recommended fuse values may create hazardous conditions.

Model 2310B & 2331: Two axial-lead internal power fuses are recommended as follows:

0.25A fast acting, Littelfuse #251.250 (UL/CSA).
(Vishay M-M #18X300007)

Model 2350/2360: A power fuse is located on the rear panel. The following lists the recommended time lag fuse ratings:

2350: UL/CSA: T 1 A IEC: T .8 A

2360: UL/CSA: T .5 A IEC: T .4 A

APPENDIX – 1000-OHM BRIDGE COMPLETION

The 2310B Signal Conditioning Amplifiers provides the capability of 1000-ohm quarter bridge operation. For this mode, the 120-ohm dummy terminal (pin B of input plug) is converted to a 1000-ohm dummy terminal by removing a solder shunt from a factory-installed precision resistor in series with the internal 120-ohm dummy gage. To make this conversion the user must desolder a solder pad located on the circuit side of the small connector PC board that is attached to the INPUT connector. The 880-ohm resistor, R1 is located on the connector-side of the board. The solder pad is located on the top-right side of the board and is shown below:

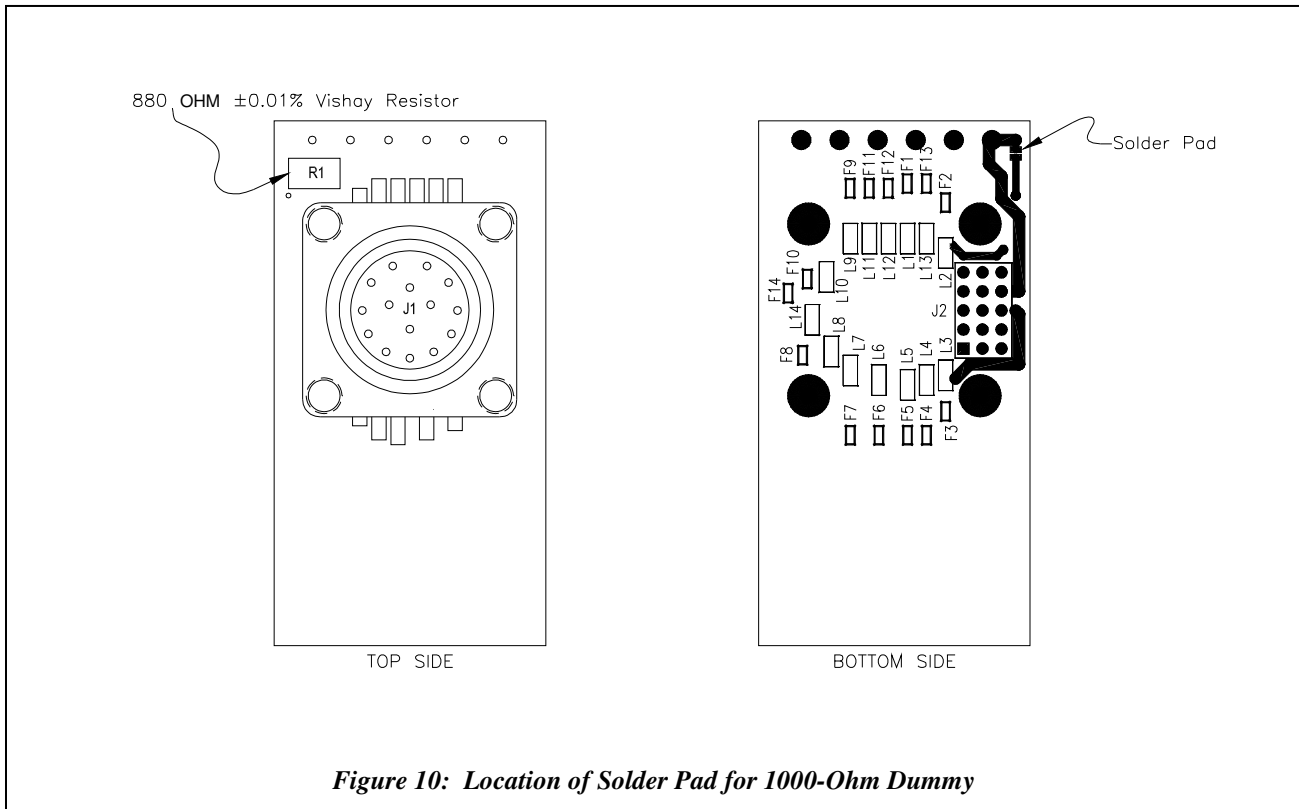

Figure 10: Location of Solder Pad for 1000-Ohm Dummy

WARRANTY

Vishay Micro-Measurements warrants all instruments it manufactures to be free from defect in materials and factory workmanship, and agrees to repair or replace any instrument that fails to perform as specified within three years after date of shipment. Coverage of computers, cameras, rechargeable batteries, and similar items, sold in conjunction with equipment manufactured by Vishay Micro-Measurements and bearing the identifying name of another company, is limited under this warranty to one year after the date of shipment. The warranty on non-rechargeable batteries and similar consumable items is limited to the delivery of goods free from defects in materials and factory workmanship. This warranty shall not apply to any instrument that has been:

- i. repaired, worked on or altered by persons unauthorized by Vishay Micro-Measurements in such a manner as to injure, in our sole judgment, the performance, stability, or reliability of the instrument;
 - ii. subject to misuse, negligence, or accident;
- or
- iii. connected, installed, adjusted, or used otherwise than in accordance with the instructions furnished by us.

At no charge, we will repair, at our plant, or an authorized repair station, or at our option, replace any of our products found to be defective under this warranty.

This warranty is in lieu of any other warranties, expressed or implied, including any implied warranties of merchantability or fitness for a particular purpose. There are no warranties, which extend beyond the description on the face hereof. Purchaser acknowledges that all goods purchased from Vishay Micro-Measurements are purchased as is, and buyer states that no salesman, agent, employee or other person has made any such representations or warranties or otherwise assumed for Vishay Micro-Measurements any liability in connection with the sale of any goods to the purchaser. Buyer hereby waives all rights buyer may have arising out of any breach of contract or breach of warranty on the part of Vishay Micro-Measurements, to any incidental or consequential damages, including but not limited to damages to property, damages for injury to the person, damages for loss of use, loss of time, loss of profits or income, or loss resulting from personal injury.

Some states do not allow the exclusion or limitation of incidental or consequential damages for consumer products, so the above limitations or exclusions may not apply to you.

The purchaser agrees that the Purchaser is responsible for notifying any subsequent buyer of goods manufactured by Vishay Micro-Measurements of the warranty provisions, limitations, exclusions and disclaimers stated herein, prior to the time any such goods are purchased by such buyer, and the Purchaser hereby agrees to indemnify and hold Vishay Micro-Measurements harmless from any claim asserted against or liability imposed on Vishay Micro-Measurements occasioned by the failure of the Purchaser to so notify such buyer. This provision is not intended to afford subsequent purchasers any warranties or rights not expressly granted to such subsequent purchasers under the law.

Vishay Micro-Measurements reserves the right to make any changes in the design or construction of its instruments at any time, without incurring any obligation to make any change whatever in units previously delivered.

Vishay Micro-Measurements' sole liabilities, and buyer's sole remedies, under this agreement shall be limited to the purchase price, or at our sole discretion, to the repair or replacement of any instrument that proves, upon examination, to be defective, when returned to our factory, transportation prepaid by the buyer, within the applicable period of time from the date of original shipment.

Return transportation charges of repaired or replacement instruments under warranty will be prepaid by Vishay Micro-Measurements.

Vishay Micro-Measurements is solely a manufacturer and assumes no responsibility of any form for the accuracy or adequacy of any test results, data, or conclusions, which may result from the use of its equipment.

The manner in which the equipment is employed and the uses to which the data and test results may be put are completely in the hands of the Purchaser. Vishay Micro-Measurements shall in no way be liable for damages consequential or incidental to defects in any of its products.

This warranty constitutes the full understanding between the manufacturer and buyer, and no terms, conditions, understanding, or agreement purporting to modify or vary the terms hereof shall be binding unless hereafter made in writing and signed by an authorized official of Vishay Micro-Measurements.