

1-1/4" End Mill
 Clockwise Rotation
 RPM: 300

Rotation direction

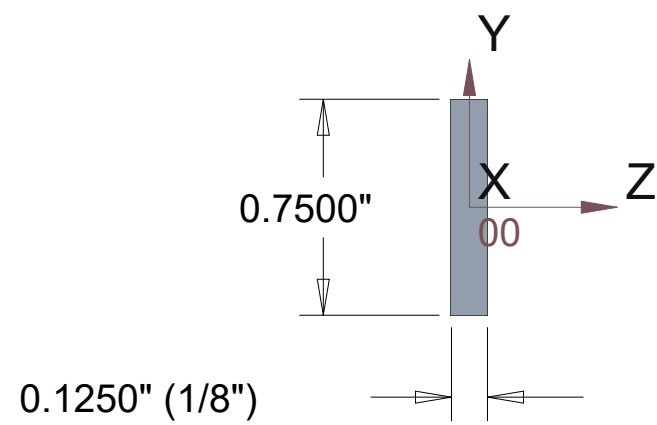

Minnesota State University
 Mechanical & Civil Engineering
 205 Trafton East
 Mankato, MN 56001

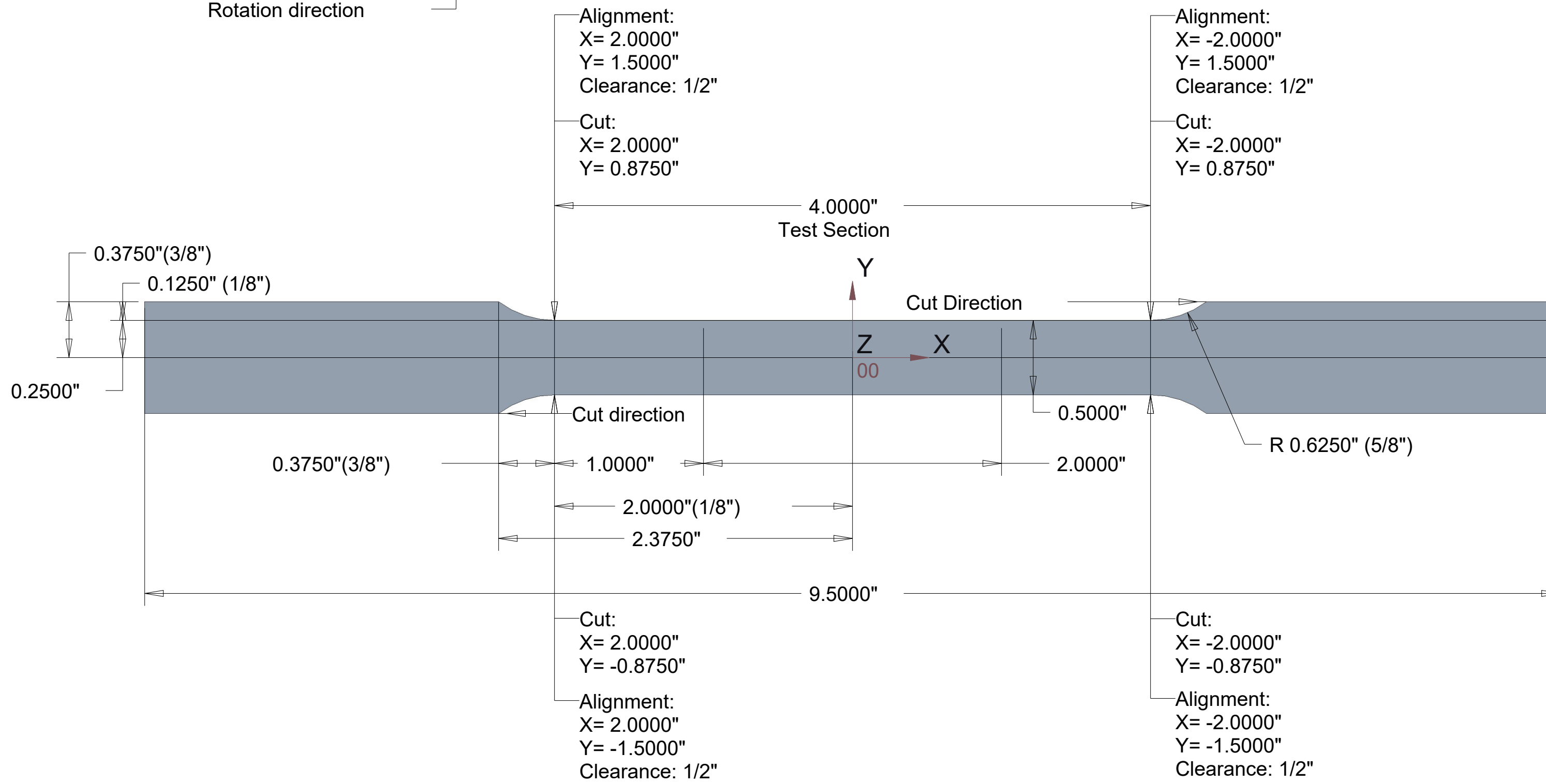

Title: TestSample Dogbone 1.25/2= 0.625" Radius	Revision: 1	Date: 2-15-2018	Scale: 1.5	Paper: C
Part: Fatigue/ Tensile 1/8"X9.5" 4-1/4"TestSec	Revision:	Quantity:	Note: Revision Scheme: Frame Rev-Part Rev	
Author: Kevin Schull, Engineering Specialist Senior (507) 389-1566				
Drawing #: 1				