

# POWERPRO

Replacement Parts Manual

Cast Iron  
Compressors

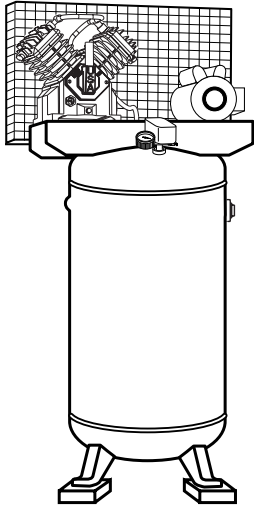

Model	Pump
CIQ51089VP	TQ300100AJ
CI071089VPMS	CI070000PP
CI103129HPMS	CI100000PP
CI153129HPMS	CI150000PP
CI051089VPMS	CI050000PP

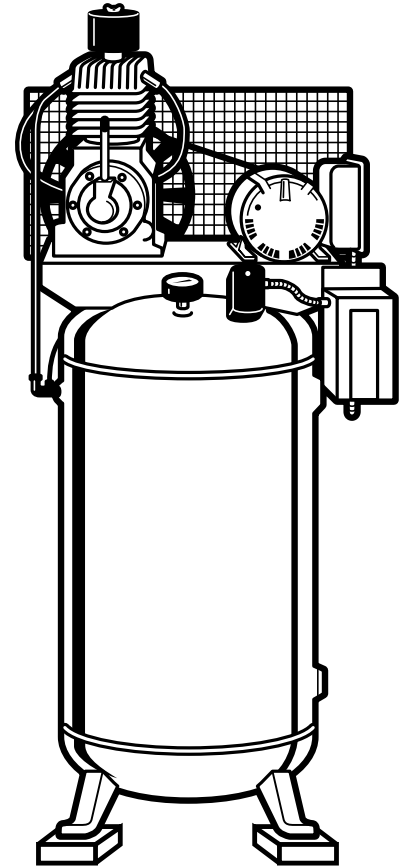
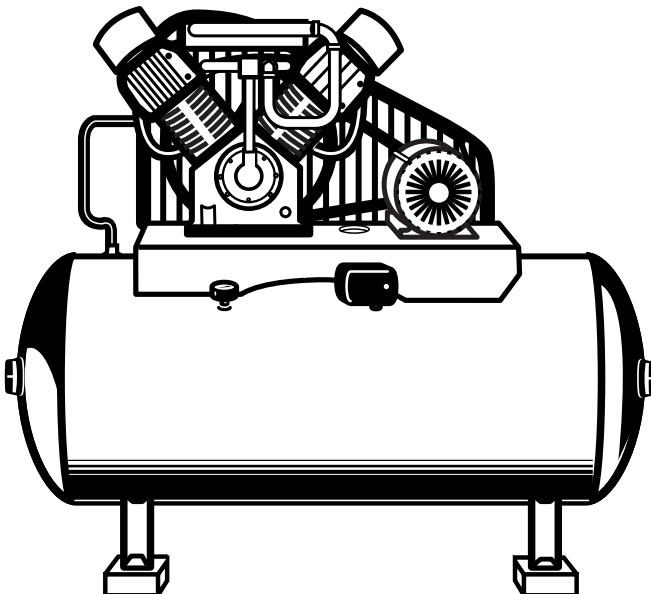
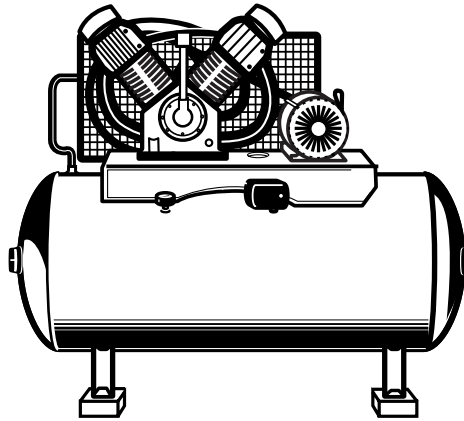

## Specifications

Motor HP	Volts/Phase	Minimum Circuit	Discharge Pressure	Delivery SCFM	Pump RPM	Oil Capacity	Oil Type
5	230 V / 1 Ø	28 Amps	135 psi	14.9	850	45 oz.	ISO 100 (SAE 30) # ST126700AV

### Model CIQ51089VP

#### Dimensions

A	Width	33"
B	Boltdown (120° apart)	27"
C	Height	68"
D	Tank outlet to feet	40"
E	Depth	26"
F	Isolation pads	3/4"

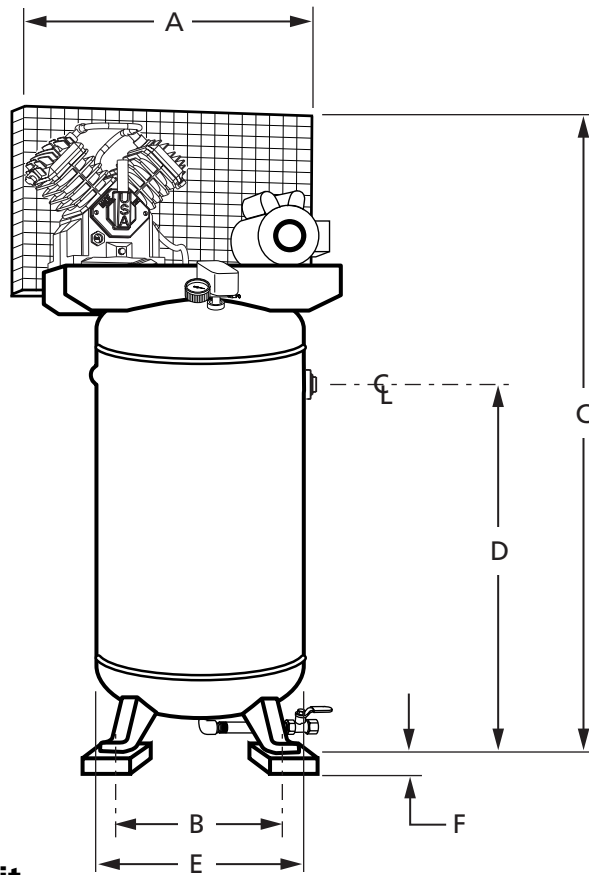

Figure 1

## Replacement Parts List for Compressor Unit

Ref. No.	Description	Part Number	Qty
1	Air tank	TF006604AJ	1
2	Elbow	ST071212AV	1
3 †	Pump w/o flywheel	TQ300100AJ	1
4	5/16"- 18 x 1 1/2" Hex head bolt	ST012100AV	4
5	5/16"-18 Locknut	ST146000AV	8
6	5/16"-18 x 3/4" Hex head bolt	ST016000AV	4
7	5/16" Washer	ST077303AV	4
8	Electric motor	MC022396AV	1
9	Motor pulley	PU009769AV	1
10	Key	KE000903AV	1
11	Flywheel	PU011104AV	1
12	Washer	ST124200AV	1
13	Lockwasher	ST071012AV	1
14	7/16" Torque bolt	TF058100AV	1
15	Belt	BT010600AV	1
16	Pipe nipple	HF002401AV	1
17	5/16" Washer	ST077303AV	4
18	Pressure gauge	GA016700AV	1
19	Safety valve	V-215105AV	1
20	Electric cord	EC100000AV	1
21	Teflon tubing	RO090400AY	1.4'

Ref. No.	Description	Part Number	Qty
22	Straight push connect	ST119301AV	1
23	Check valve	CV220301AJ	1
24	1/2" Compression sleeve	ST032900AV	1
25	1/2" Compression nut	ST033001AV	1
26	Discharge tube	TQ012300AP	1
27	Front beltguard	BG217002AJ	1
28	10-24 Hex-flange nut	ST116201AV	5
29	5/16" Washer	ST011200AV	2
30	5/16" Self-tapping screw	ST016500AV	2
31	8-32 x 5/8" screw	ST073233AV	4
32	Air deflector	BG207400AV	2
33	Back beltguard	BG217100AJ	1
34	Pressure switch	CW207574AV	1
35	Isolation pads (Kit of 3)	ZZ000043AJ	1
36	Pipe nipple	ST070355AV	1
37	Ball valve	ST079802AV	1
Δ	ASME Port o-ring	PG201002AV	1
Δ	ASME Port plug	PG201006AV	1
Δ	O-ring	ST070190AV	2

(†) Refer to pump parts list for replacement parts

(Δ) Not shown

# For Replacement Parts, Call 1-888-636-6628

Please provide following information:

- Model number
- Serial number (if any)
- Part description and number as shown in parts list

Address parts correspondence to:

PowerPro  
Attn: Parts Department  
100 Production Drive  
Harrison, OH 45030

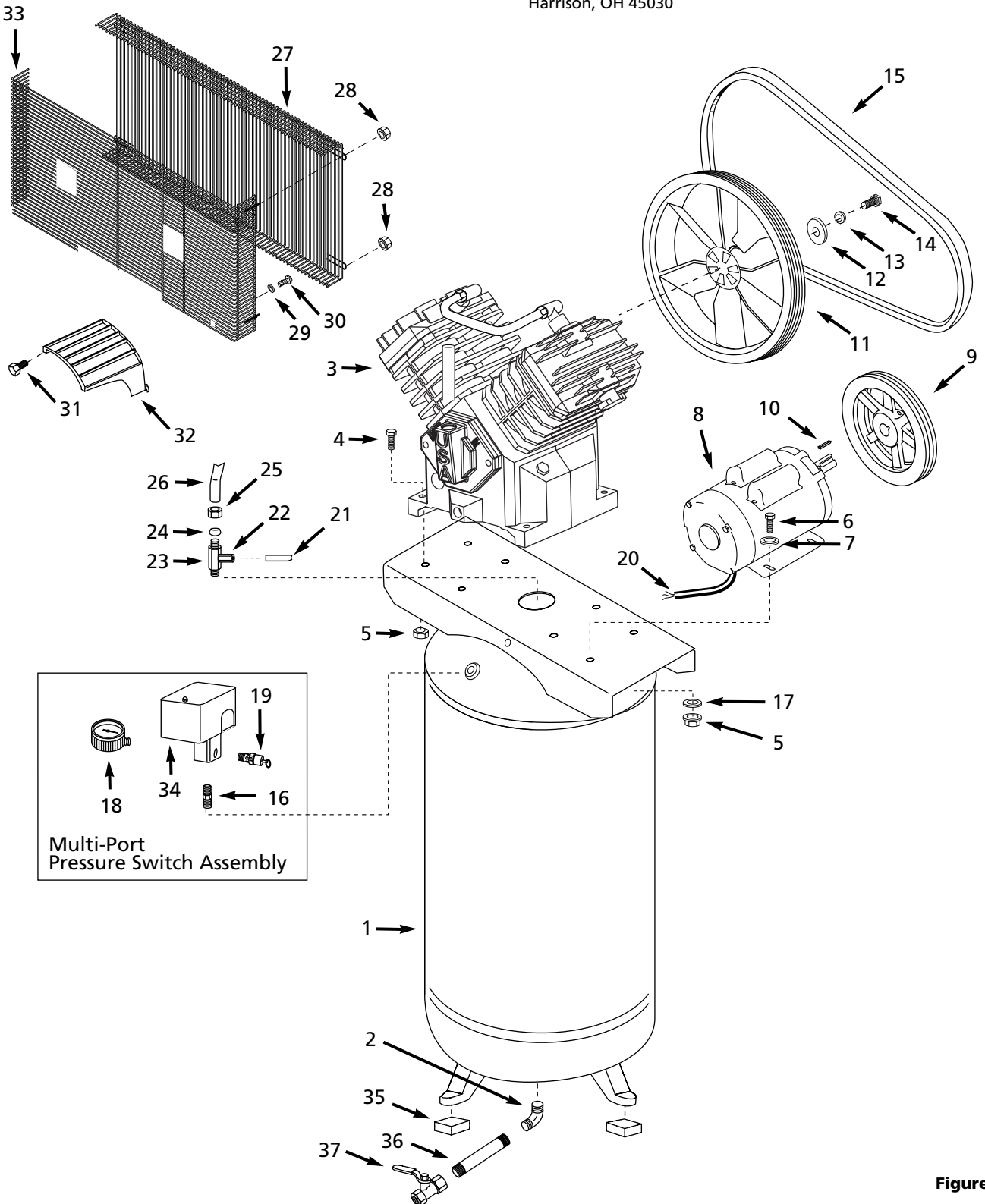

Figure 2

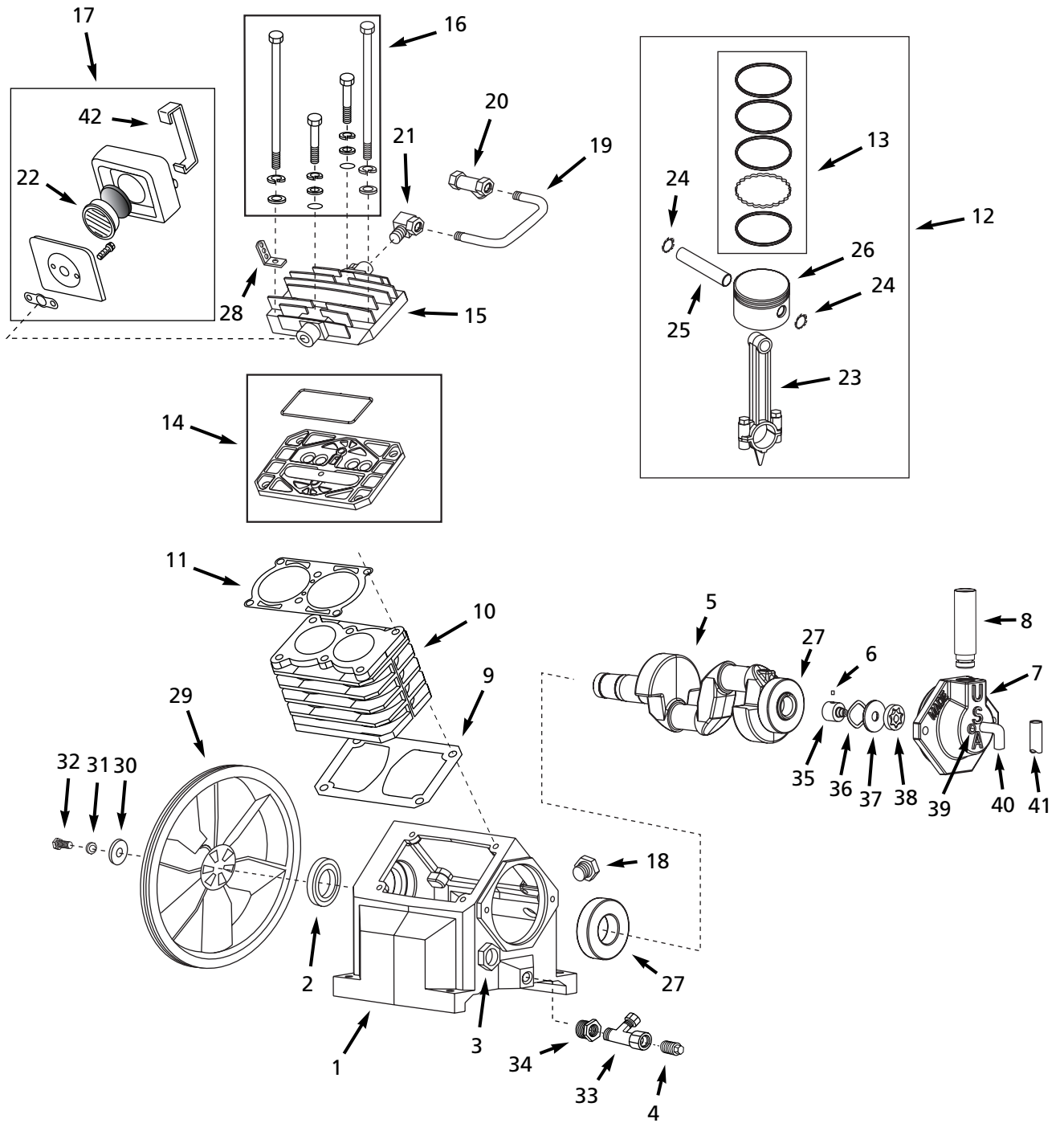

Figure 3

## For Replacement Parts, Call 1-888-636-6628

Please provide following information:

- Model number
- Serial number (if any)
- Part description and number as shown in parts list

Address parts correspondence to:

PowerPro  
Attn: Parts Department  
100 Production Drive  
Harrison, OH 45030

### Replacement Parts List for Pump

Ref. No.	Description	Part Number	Qty
1	Crankcase	TQ010000AG	1
2	Oil Seal	ST120000AV	1
3	Sight glass	TF050102AV	1
4	1/4" NPT oil drain plug	ST072917AV	1
5	Crankshaft	TQ010300AG	1
6	Driver pin	ST070098AV	1
7	Bearing cap	TQ010500AG	1
8	Breather assembly	TQ900300AJ	1
9	Crankcase gasket	XA011100AV	2
10	Cylinder	VT040700AG	2
11	Cylinder gasket	XA011900AV	2
12	Connecting rod/ piston assembly kit	TQ900600AJ	4
13	Piston ring kit	TQ900700AJ	4
14	Valve plate assembly	TQ900400AJ	2
15	Cylinder head	VT040400AG	2
16	Head/cylinder fastener kit	TQ900800AJ	2
17	Air filter assembly	TQ900100AJ	2
18	Oil fill plug	ST178200AV	1
19	Crossover tube	TQ010700AP	1
20	Tee	ST178000AV	1
21	Elbow	ST072214AV	1
22	Filter element	ST163100AV	2
23	Connecting rod	TQ010900AG	4
24	Star washer	ST070236AV	8
25	Wrist pin	VS001400AV	4
26	Piston	TQ011900AG	4
27	Bearing	ST106900AV	2
28	Belt guard bracket	TQ012000AV	1
29	Flywheel	PU011104AV	1
30	Washer	ST124200AV	1
31	Split washer	ST071012AV	1
32	Bolt	TF058100AV	1
33	Pipe tee	ST160600AV	1
34	Reducer bushing	ST006400AV	1
35	Oil pump driver	TQ011400AV	1
36	Spring washer	ST075902AV	1
37	Oil pump washer	TQ011500AV	1
38	Oil gerotor pump	TQ011000AV	1
39	1/4" Pipe plug	ST022500AV	1
40	Compression elbow	ST072218AV	1
41	Oil pump tubing	TQ012500AP	1
42	Air filter bracket	TQ011100AV	2

# Specifications

Motor HP	Volts/Phase	Minimum Circuit	Discharge Pressure	Delivery SCFM	Pump RPM	Oil Capacity	Oil Type
7.5	230 V / 1 Ø	40 Amps	175 psi	25.1	1020	2 qts.	ISO 100 (SAE 30) # ST126700AV

## Model CI071089VPMS

### Dimensions

A	Overall width	33"
B	Boltdown width (120° apart)	27"
C	Overall height	78"
D	Tank outlet to feet	40"
E	Overall depth	26"
F	Isolation pads	3/4"

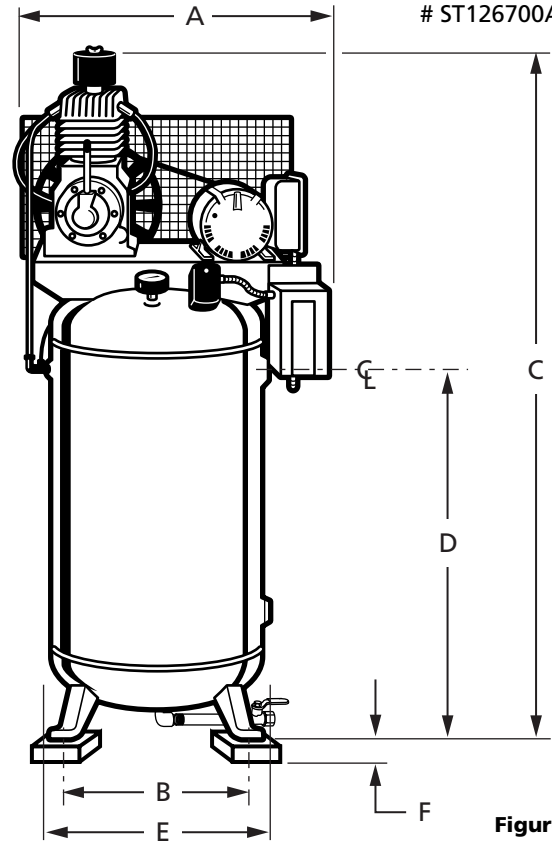

Figure 4

## Replacement Parts List for Compressor Unit

Ref. No.	Description	Part Number	Qty
1	Air compressor pump	TF310100AJ	1
2	Isolation pads (kit of 3)	ZZ000043AJ	1
3	Tank	TF006605CG	1
4	7/16" - 14 x 1½" Hex head screw	ST070645AV	4
5	7/16" Washer	ST070916AV	8
6	7/16" - 14 Hex nut	ST036300AV	4
7	Elbow	ST071212AV	1
8	Discharge tube	TF061500AV	1
9	Nut and ferrule	ST072321AV	1
10	90° Compression fitting	ST072231AV	1
11	1/4" Compression fitting	ST011701AV	1
12	1/4" NPT, 300 PSI pressure gauge	GA016703AV	1
13	1/4" - 18 x 2½" Pipe nipple	ST070307AV	
14	Safety valve	V-215200AV	1
15	Pressure switch, 145/175	CW207561AV	1
16	Copper tube	R-060600AY	2 ft.
17	Motor	MC301521AV	1
18	5/16" - 18 x 1/2" Set screw	ST026400AV	2
19	Belt	BT008500AV	1
20	Pulley	PU009750AV	1
21	3/8" - 16 x 1¼" Screw	ST070654AV	4
22	3/8" Washer	ST070914AV	8
23	3/8" - 16 Nut	ST057600AV	4
24	Belt guard front	BG217000AV	1
25	Belt guard back	BG217100AV	1

Ref. No.	Description	Part Number	Qty
26	Cap	ST075400AV	4
27	Hex flange nut	ST116201AV	2
28	Bolt	ST016500AV	2
29	Washer	ST011200AV	2
30	1/4" - 20 x 1½" Bolt	ST023400AV	1
31	1/4" Washer	ST000600AV	1
32	Beltguard bracket	TF063100AV	1
33	3/4" check valve	CV003205AV	1
34	3/4" x 1/4" reducer bushing	ST151000AV	1
35	Magnetic starter bracket	BG215300AV	1
36	Self-threading screw	ST016500AV	2
37	Magnetic starter assembly	ST122010AJ	1
38	Low oil guard (230V only)	TF062800AJ	1
39	Pipe nipple	ST070355AV	1
40	Ball valve	ST079802AV	1
Δ	ASME Port o-ring	PG201002AV	1
Δ	ASME Port plug	PG201006AV	1
Δ	O-ring	ST070190AV	2

(Δ) Not shown

Unloader valve for pressure switch available separately, part number CW000200AV

Heater element for magnetic starter assembly available separately, part number PS005551AV

# For Replacement Parts, Call 1-888-636-6628

Please provide following information:

- Model number
- Serial number (if any)
- Part descriptions and number as shown in parts list

Address parts correspondence to:

PowerPro  
 Attn: Parts Department  
 100 Production Drive  
 Harrison, OH 45030

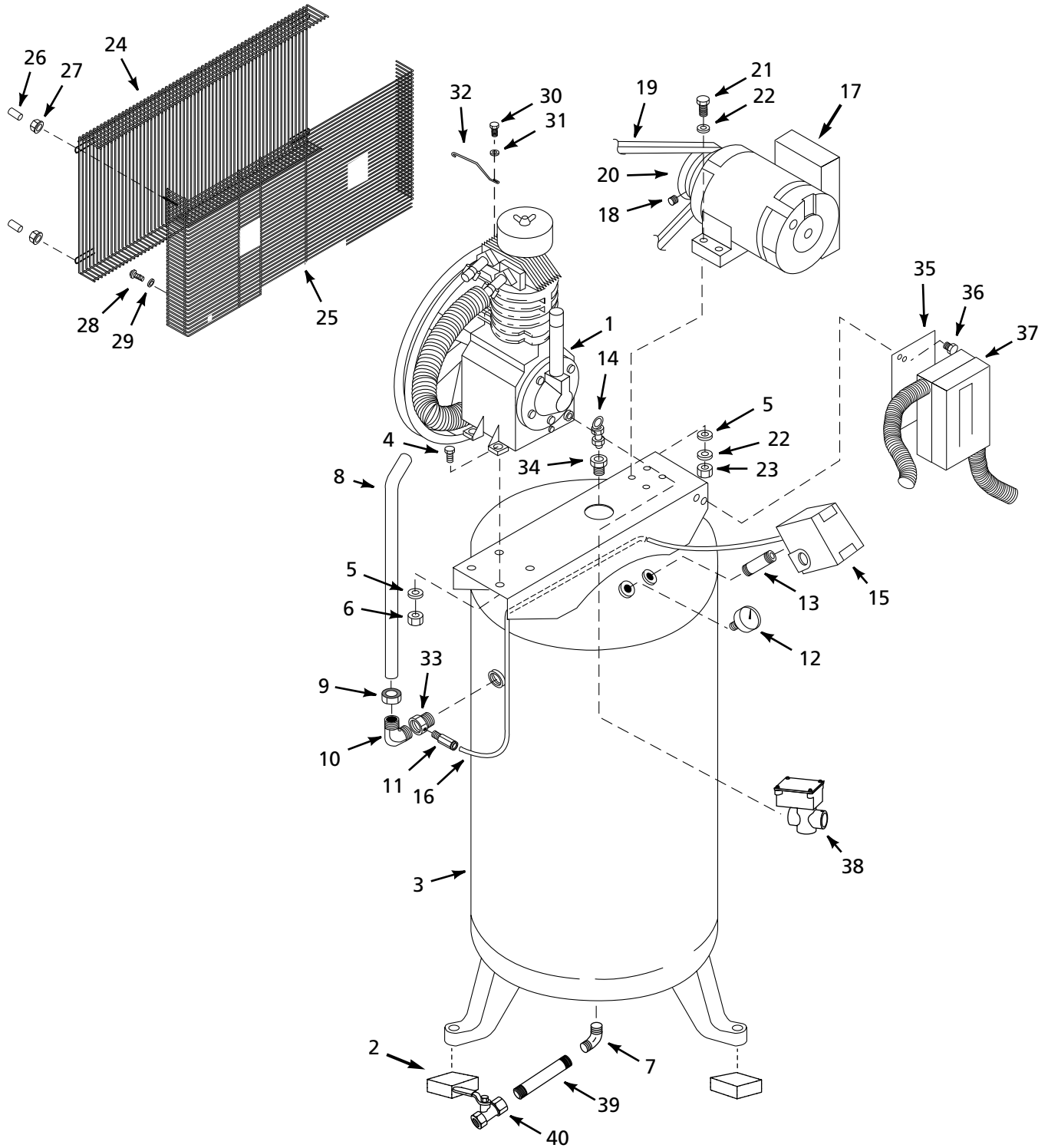

Figure 5

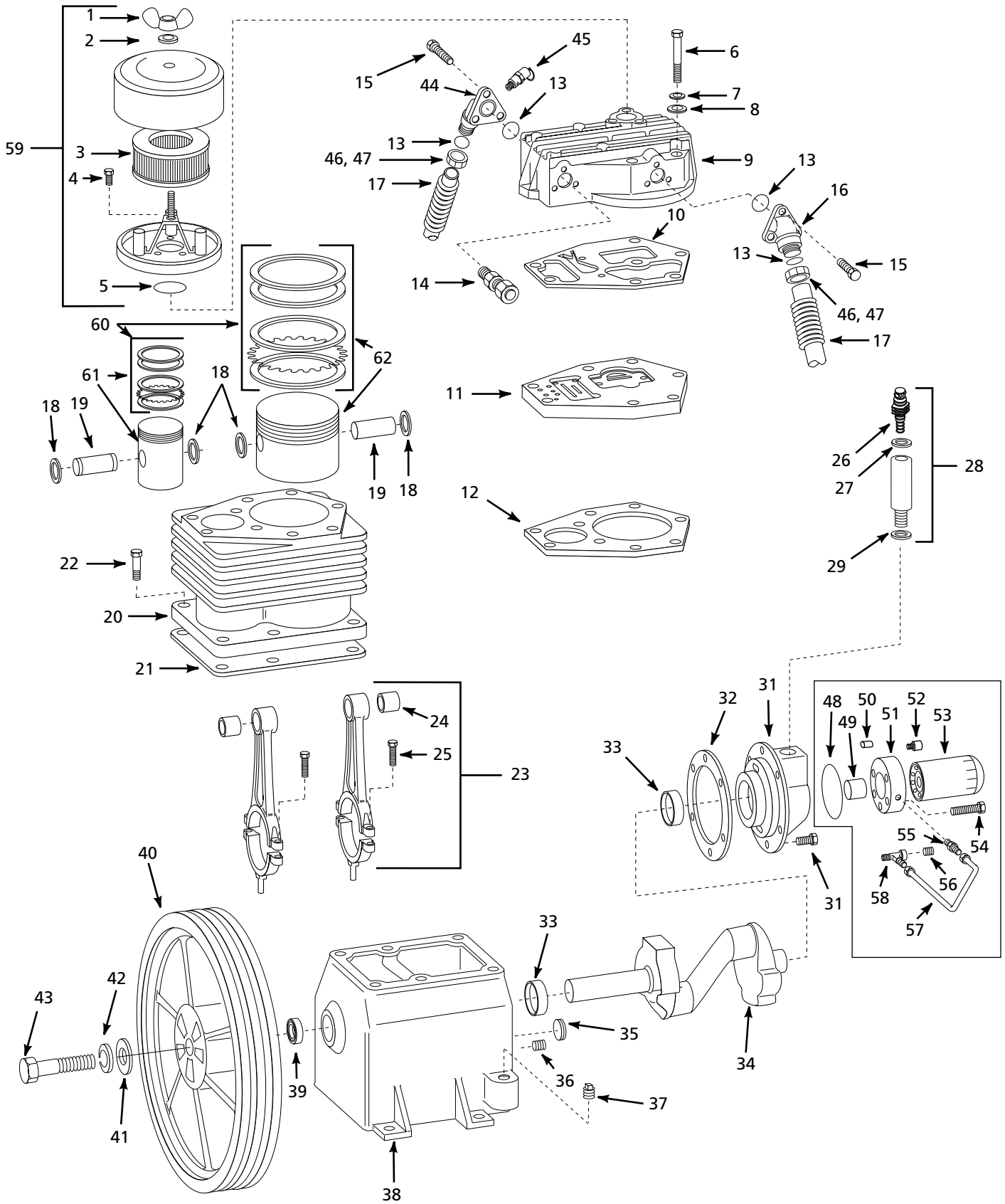

Figure 6



# For Replacement Parts, Call 1-888-636-6628

Please provide following information:

- Model number
- Serial number (if any)
- Part descriptions and number as shown in parts list

Address parts correspondence to:

PowerPro  
 Attn: Parts Department  
 100 Production Drive  
 Harrison, OH 45030

Ref. No.	Description	Part No.	Qty.	Ref. No.	Description	Part No.	Qty.
1	1/4"-20 Wing nut	*	1	37	1/2"-14 NPT Filler plug	ST066400AV	1
2	1/4" Washer	*	1	38	Crankcase assembly	TF050202AJ	1
3	Filter element	TF060504AV	1	39	Oil seal	ST066900AV	1
4	1/4-20 x 1/2" screw	ST074401AV	3	40	Flywheel	PU011106AV	1
5	O-ring	---	1	41	Washer	ST124200AV	1
6	3/8"-16 x 3 1/2" Screw	ST070684AV	9	42	Lockwasher	ST071012AV	1
7	3/8" Bellville washer	ST158100AV	9	43	1/2"-13 Screw	TX034700AV	1
8	3/8" Plain washer	ST057700AV	9	44	Tube fitting	TF060403AJ	1
9	Cylinder head	TF060101AG	1	45	Safety valve	V-208900AV	2
10	1 Head gasket	TF060300AV	1	46	Tube nut	ST072315AV	1
11	Valve plate assembly	TF059700AJ	1	47	Ferrule	TF064400AV	1
12	1 Gasket, cylinder to valve plate	TF061301AV	1	48	Seal	TF202400AV	1
13	1 O-ring	ST070186AV	6	49	Oil Pump	TF202100AV	1
14	1/2" NPT x 3/4" Comp. fitting	ST072025AV	1	50	Drive pins	ST119204AV	1
15	1/4"-20 x 3/4" Screw	ST120200AV	8	51	Oil filter housing	TF201800AJ	1
16	Tube fitting	TF060402AV	1	52	Oil filter reducer fitting	TW013200AV	1
17	Intercooler	TF002001BH	1	53	Oil filter	TF202700AV	1
18	Retaining ring	ST059400AV	4	54	Bolt	ST070808AV	3
19	Piston pin	TF000500AV	2	55	Fitting	ST049600AV	1
20	Cylinder	TF058000AG	1	56	1/4"-18 NPT Drain plug	ST022000AV	1
21	1 Gasket, cylinder to crankcase	XA006200AV	1	57	Oil tube	TF202600AP	1
22	3/8"-24 x 1" Hex head screw	ST067200AV	6	58	Pipe tee	ST160600AV	1
23	Connecting rod assembly	TF057800AJ	2	<b>REPLACEMENT KITS AND ACCESSORIES</b>			
24	Needle bearing	ST051100AV	2	59	Filter kit (Incl. Ref. #1-5)	TF060501AV	1
25	5/16"-18 x 1 1/2" Socket head screw	*	4	60	Ring kit	TF006900AJ	1
26	Breather cap	VT041702AV	1	61	High pressure piston assembly	TF002300AJ	1
27	O-Ring	ST164402AV	1	62	Low pressure piston assembly	TF002400AJ	1
28	Breather tube assembly with cap (Only available as complete assembly)	TF057601AJ	1	1	Gasket kit	TF061600AJ	1
29	O-ring	ST070176AV	1	s	++ Threaded air intake adapter (not shown)	TF060502AV	1
30	16-18 x 3/4" Socket screw	ST070802AV	6	t	++ Threaded air filter kit	ST073902AV	1
31	Bearing cap	TF060900AG	1	(*)	Standard hardware item, available locally		
32	1 0.015" Gasket	XA006102AV	1	(s)	Optional adapter kit provides 1" NPT threads at pump head, Requires piping between pump and filter kit ST073902AV		
33	Ball bearing	ST129200AV	2	(t)	Filter kit required for optional adapter kit TF060502AV		
34	Crankshaft w/bearings	TF053701AJ	1	(++)	Optional		
35	Oil level gage	TF050101AV	1				
36	1/4"-18 NPT Drain plug	ST022000AV	1				

### TORQUE VALUES

Ref No.	Description	Torque
6	3/8"-16 Screw, head	42 ft. lb.
22	3/8"-24 Screw, cylinder	15 ft. lb.
25	5/16"-18 Screw, connecting rod	14 ft. lb.
30	5/16"-18 Screw, bearing cap	14 ft. lb.
43	1/2" Torque screw, flywheel	50 ft. lb.

## Specifications

Motor HP	Volts/Phase	Minimum Circuit	Discharge Pressure	Delivery SCFM	Pump RPM	Oil Capacity	Oil Type
10	208/230/460V 3Ø	32/28/14 Amps	175 psi	35.2	700	4 qts.	ISO 100 (SAE 30) # ST126700AV

### Model CI103129HPMS

#### Dimensions

A	Base - width	70 ½"
B	Boltdown width (center to center)	42 "
C	Overall height	52 ½"
D	Tank outlet to feet	15 ¾"
E	Δ Overall depth	26 "
F	Δ Boltdown depth (center to center)	18 "
G	Isolation pads	¾ "

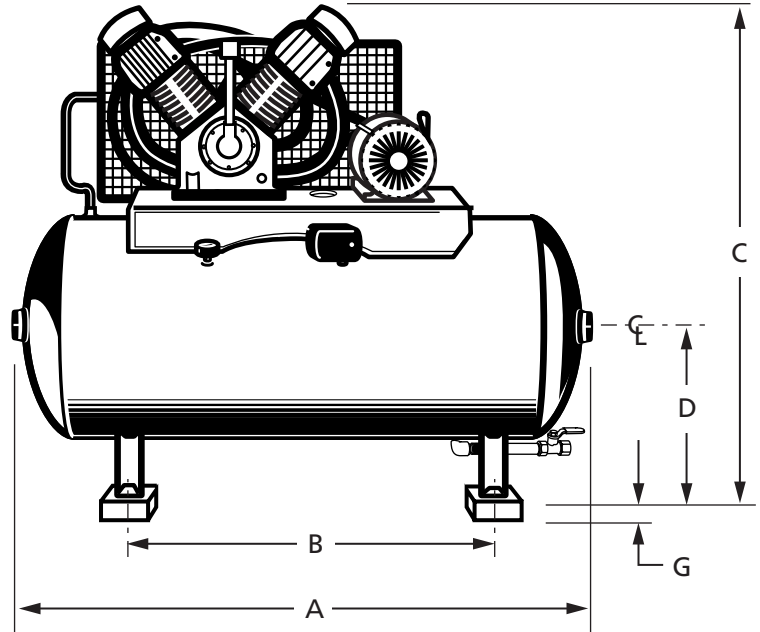

Figure 7

## Replacement Parts List for Compressor Unit

Ref. No.	Description	Part Number	Qty.
1	Air compressor pump	u CI100000PP	1
2	Tank	TF003703AJ	1
3	1/2"-13 x 1 1/2" Hex head screw	]	4
4	1/2" Washer	]	8
5	1/2"-13 Hex nut	]	4
6	Elbow	ST071212AV	1
7	Tube	TX031900AP	1
8	90° Compression fitting	ST072231AV	1
9	3/4" Check valve	CV003205AV	1
10	Pressure gauge	GA016703AV	1
11	1/4"-18 x 2 1/2" Pipe nipple	ST070387AV	1
12	Safety valve	V-215200AV	1
13 †	Pressure switch, 145/175	CW207561AV	1
14	Copper tube	R060600AY	4 ft.
15	Motor	MC022395AV	1
16	5/16"-18 x 1/2" Set screw	ST026400AV	2
17	Belt	BT022100AV	2
18	Pulley	PU008002AV	1
19	3/8"-16 x 1 1/4" Screw	]	4
20	3/8" Washer	]	8
21	7/16" Washer	]	4
22	3/8"-16 Nut	]	4
23	Belt guard front	BG217000AJ	1
24	Belt guard back	BG217100AJ	1
25	Safety cap	ST075400AV	5

Ref. No.	Description	Part Number	Qty.
26	10-24 Flanged nut	ST116201AV	5
27	5/16"-12 x 3/4" Self thread screw	ST016500AV	2
28	5/16" Washer	]	2
29	1/4"-20 x 5/8" Screw	]	1
30	1/4" Washer	]	1
31	Belt guard bracket	TF063200AV	1
32	Mounting bracket	BG215300AV	1
33	Mounting screw	ST016500AV	2
34	Starter w/ enclosure	ST122007AJ	1
35	Isolation pads (kit of 4)	ZZ000127AJ	1
36	Low oil guard (230V only)	TF062800AV	1
37	Pipe nipple	ST070355AV	1
38	Ball valve	ST079802AV	1
Δ	Heaters B-50	PS005555AV	3
Δ	ASME Port o-ring	PG201003AV	1
Δ	ASME Port plug	PG201001AV	1
Δ	O-ring	ST070190AV	2

(Δ) Not shown.

(j) Standard hardware item, available locally.

(†) Unloader valve available separately, Part Number CW000200AV.

(u) When ordering pump replacement parts, see compressor nameplate for exact model number.

# For Replacement Parts, Call 1-888-636-6628

Please provide following information:

- Model number
- Serial number (if any)
- Part description and number as shown in parts list

Address parts correspondence to:

PowerPro  
 Attn: Parts Department  
 100 Production Drive  
 Harrison, OH 45030

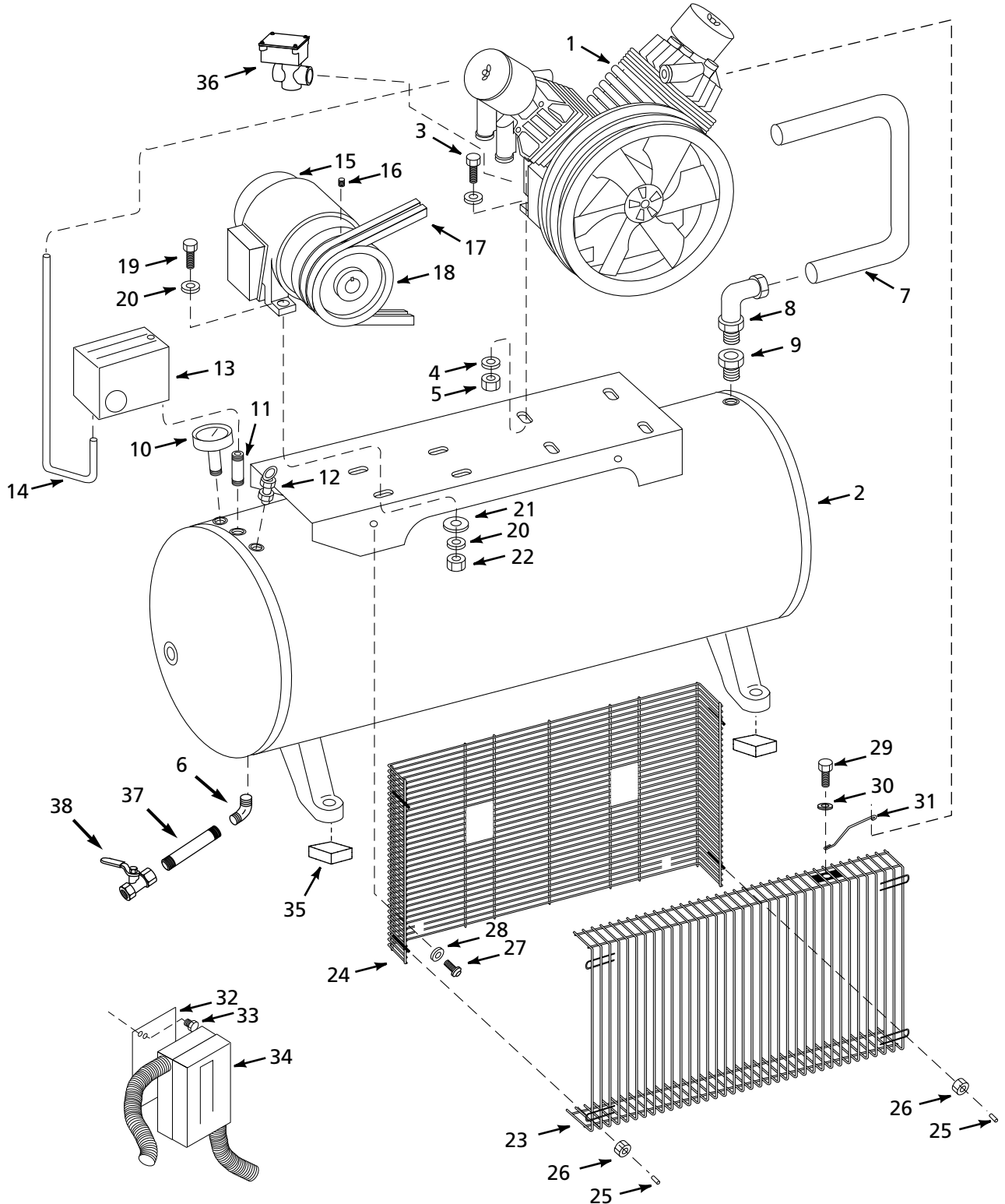

Figure 8

## Specifications

Motor HP	Volts/Phase	Minimum Circuit	Discharge Pressure	Delivery SCFM	Pump RPM	Oil Capacity	Oil Type
15	208/230/460V 3Ø	49/42/21 Amps	175 psi	51	1020	4 qts.	ISO 100 (SAE 30) # ST126700AV

### Model CI153129HPMS

#### Dimensions

A	Base - width	70 ½"
B	Boltdown width (center to center)	42 "
C	Overall height	52 ½"
D	Tank outlet to feet	15 ¾"
E	Δ Overall depth	26 "
F	Δ Boltdown depth (center to center)	18 "
G	Isolation pads	3/4 "

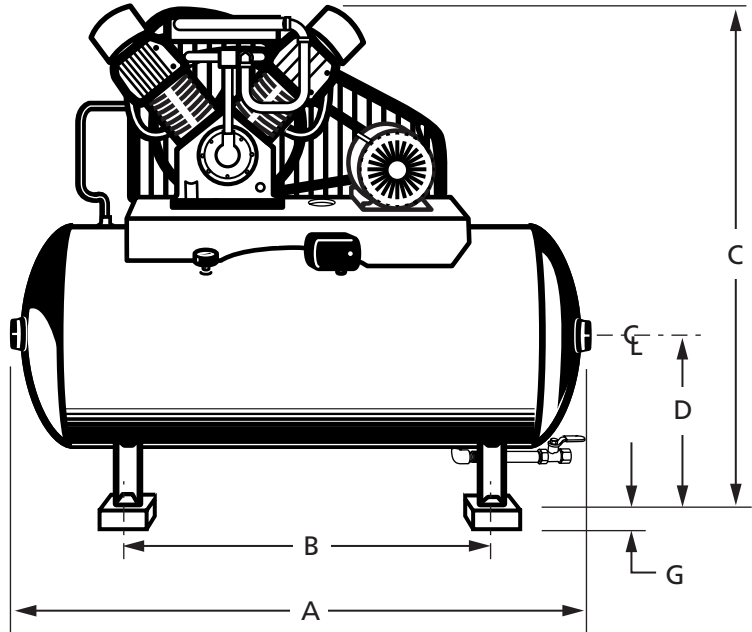

Figure 9

## Replacement Parts List for Compressor Unit

Ref. No.	Description	Part Number	Qty.
1	Air compressor pump	u CI150000PP	1
2	Tank	AR023501AJ	1
3	1/2"- 13 x 1 1/2" Hex head bolt	ST070648AV	4
4	1/2" Washer	ST070918AV	4
5	1/2"- 13 Hex nut	ST070733AV	4
6	Elbow	ST071212AV	1
7	Discharge tube	TX034000AP	1
8	Compression nut	ST072321AV	1
9	3/4" Check valve	CV003404AJ	1
10	Pressure gauge	GA016703AV	1
11	1/4"- 18 x 2 1/2" Pipe nipple	ST070387AV	1
12	Safety valve	V-215200AV	1
13 †	Pressure switch	CW207561AV	1
14	Copper tube	R-060600AY	4 ft.
15	Motor	MC301501AV	1
16	5/16"-18 x 1/2" Set screw	ST026400AV	2
17	89" B-section belt	BT009200AV	2
18	Pulley	PU009749AV	1
19	3/8"- 16 x 1 1/2" Bolt	ST024300AV	4
20	3/8" Washer	ST070914AV	8
21	7/16" Washer	ST070916AV	4
22	3/8"- 16 Nut	ST033500AV	4
23	Belt guard	TR001800AJ	1
24	Belt guard tray	TR001901AV	1
25	Belt guard retainer	TX033000AV	2

Ref. No.	Description	Part Number	Qty.
26	8-32 Screw	ST073224AV	4
27	5/16" Threadform bolt	ST016500AV	7
28	1/4" Lockwasher	ST029100AV	1
29	1/4"- 20 x 3/4" Bolt	ST038200AV	1
30	Belt guard bracket	TX034100AV	1
31	1/4"- 20 x 3/4" Bolt	ST074415AV	1
32	Isolation pads (kit of 4)	ZZ000127AJ	1
33	Magnetic starter (230V)	ST122023AJ	1
	Magnetic starter (460V)	ST122009AJ	1
34	Mounting bracket	BG215300AV	1
35	Mounting screw	ST016500AV	2
36	Low oil guard (230V only)	TF062800AV	1
37	Pipe nipple	ST070355AV	1
38	Ball valve	ST079802AV	1
Δ	230V Heaters	PS005560AV	3
	460V Heaters	PS005559AV	3
Δ	ASME Port o-ring	PG201003AV	1
Δ	ASME Port plug	PG201001AV	1
Δ	O-ring	ST070190AV	2

(†) Unloader valve available separately, Part Number CW000200AV.

(u) When ordering pump replacement parts, see compressor nameplate for exact model number.

(Δ) Not shown

# For Replacement Parts, Call 1-888-636-6628

Please provide following information:

- Model number
- Serial number (if any)
- Part description and number as shown in parts list

Address parts correspondence to:

PowerPro  
 Attn: Parts Department  
 100 Production Drive  
 Harrison, OH 45030

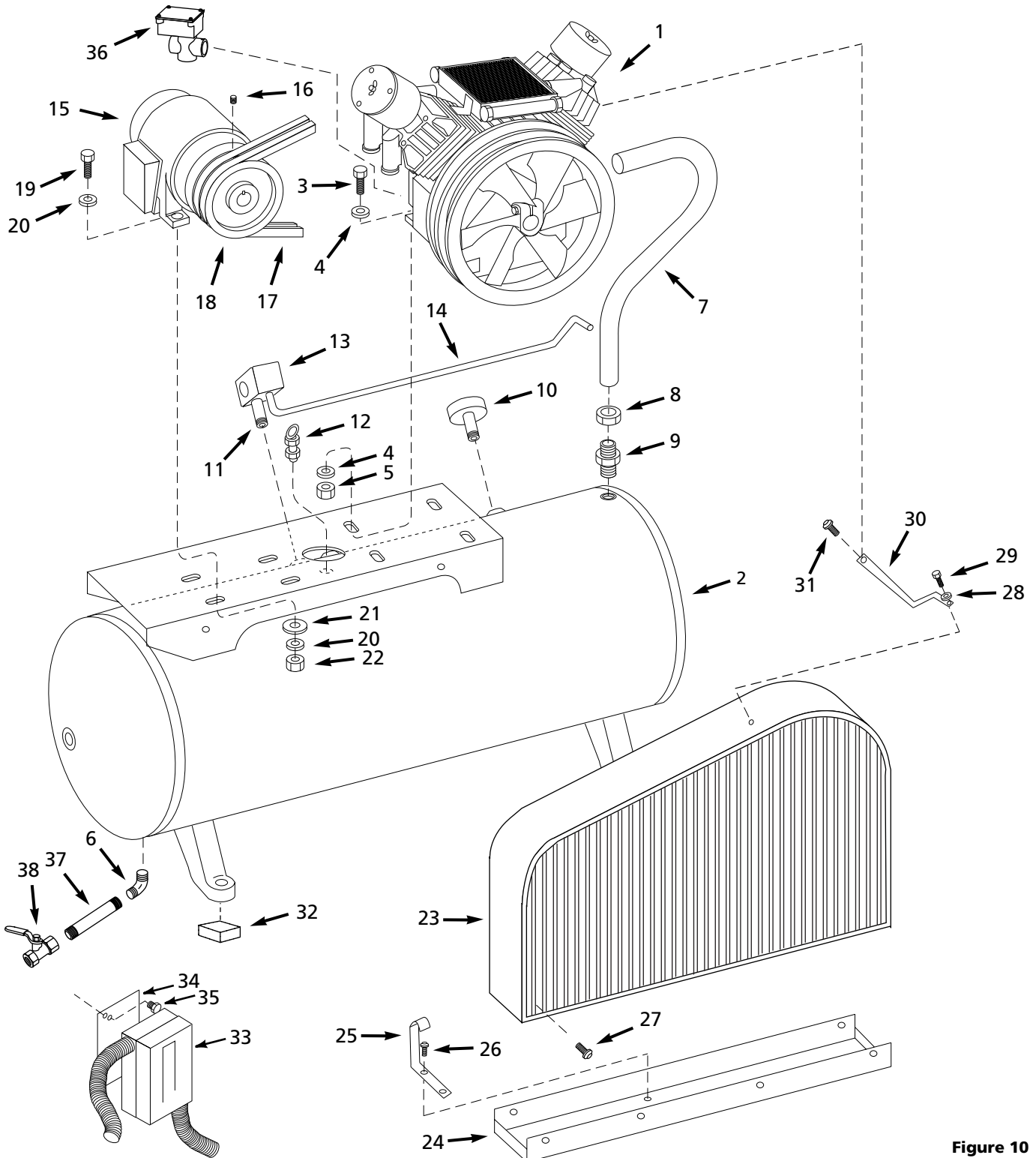

Figure 10

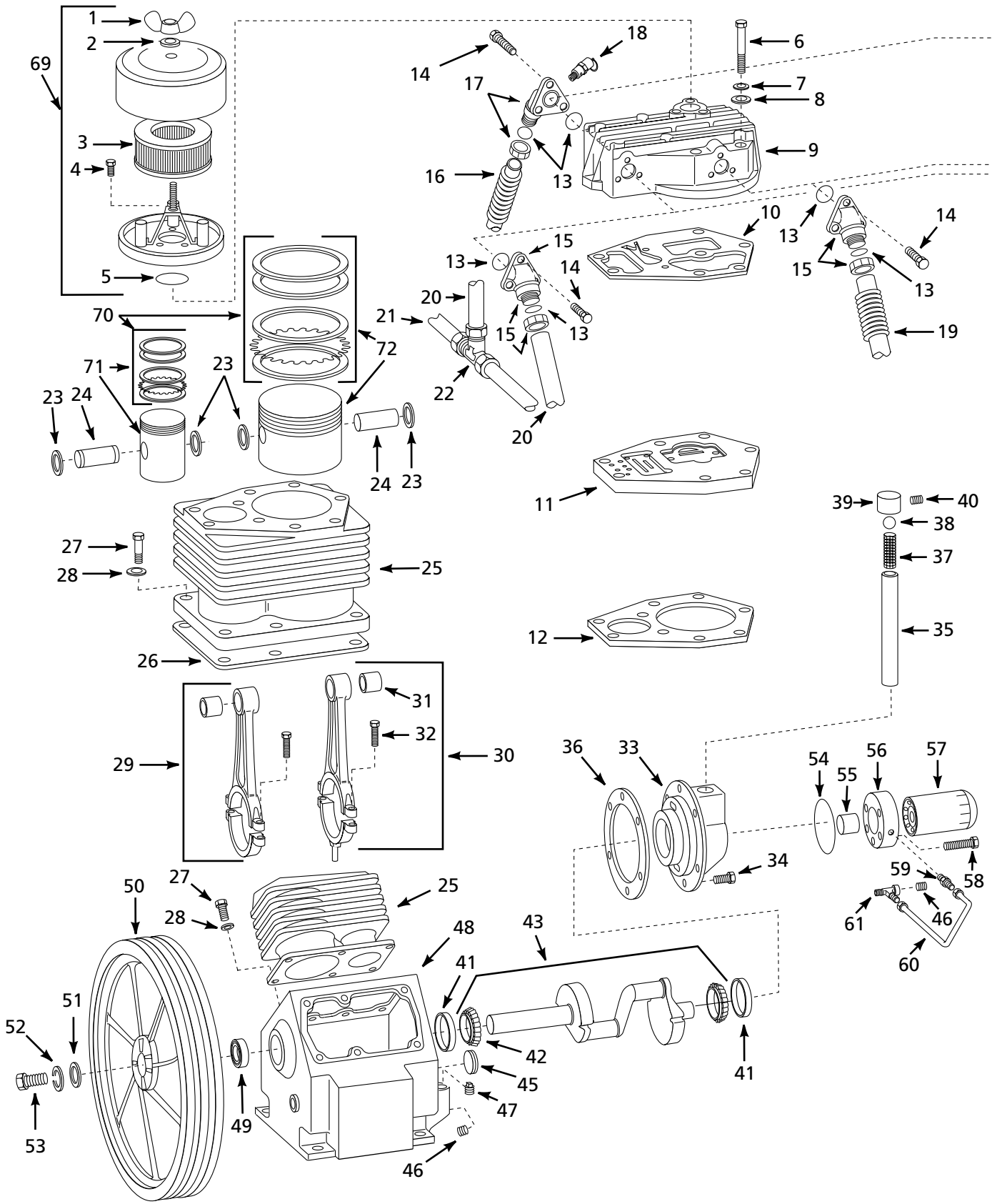
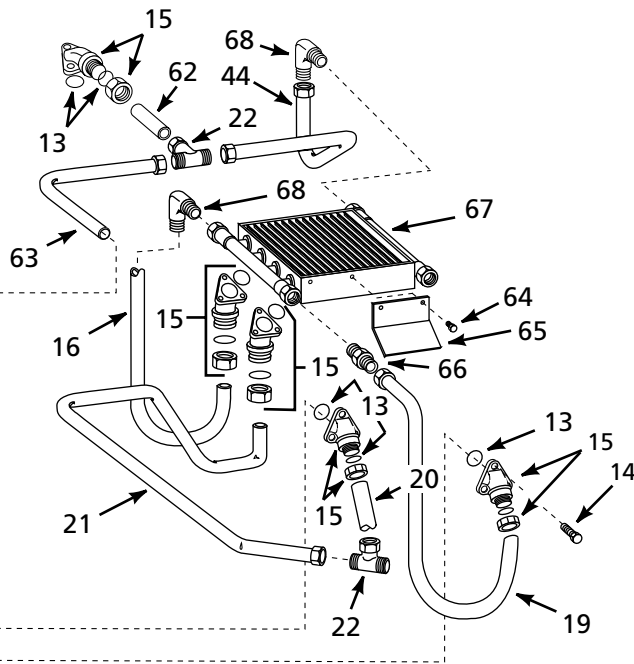

Figure 11



**For Replacement Parts, call  
1-888-636-6628**

Please provide following information:

- Model number
- Serial number (if any)
- Part description and number as shown in parts list

Address parts correspondence to:  
PowerPro / Attn: Parts Department  
100 Production Drive  
Harrison, OH 45030

**TORQUE VALUES**

Ref No.	Description	Torque
6	3/8-16 Screw, head	42 ft. lb.
27	3/8-24 Screw, cylinder	15 ft. lb.
32	5/16-18 Screw, connecting rod	14 ft. lb.
34	5/16-18 Screw, bearing cap	14 ft. lb.
53	1/2" Torque screw, flywheel	50 ft. lb.

Ref. No.	Description	Part number for model:		Qty.
		CI150000PP	CI100000PP	
1	1/4"-20 Wing nut	]	]	1
2	1/4" Washer	]	]	1
3	Filter element	TF060504AV	TF060504AV	2
4	1/4"-20 x 1/2" screw	ST074401AV	ST074401AV	3
5	O-ring	---	---	1
6	3/8"-16 x 3 1/2" Screw	ST070684AV	ST070684AV	18
7	3/8" Bellville washer	ST158100AV	ST158100AV	18
8	3/8" Plain washer	ST057700AV	ST057700AV	18
9	Cylinder head	TF060101AG	TF060101AG	2
10	1 Head gasket	TF060300AV	TF060300AV	2
11	Valve plate assembly	TF059700AJ	TF059700AJ	2
12	1 Gasket, cylinder to valve plate	TF061301AV	TF061301AV	2
13	1 O-ring	ST070186AV	ST070186AV	12
14	1/4"-20 x 3/4" Screw	ST120200AV	ST120200AV	24
15	Tube fitting assembly	TF060402AJ	TF060402AJ	4
16	Intercooler, right cyl. (facing flywheel)	TX033700AP	TX000900BH	1
17	Tube fitting assembly	TF060403AJ	TF060403AJ	2
18	Safety valve	V-208900AV	V-208900AV	2
19	Intercooler, left cyl. (facing flywheel)	TX033600AP	TX000800BH	1
20	Discharge tube	TX032000AP	TX032000AP	1
21	Crossover tube	TX031600AP	TX031600AP	1
22	3/4" Compression tee	ST072110AV	ST072110AV	2
23	Retaining ring	ST059400AV	ST059400AV	8
24	Piston pin	TF000500AV	TF000500AV	4
25	Cylinder	TF058000AG	TF058000AG	2
26	1 Gasket, cylinder to crankcase	XA006200AV	XA006200AV	2
27	3/8"-24 x 1" Hex head screw	ST067200AV	ST067200AV	12
28	3/8" Washer	ST077802AV	ST077802AV	12
29	Connecting rod assembly less dipper	TF057802AJ	TF057802AJ	2
30	Connecting rod assembly with dipper	TF057801AJ	TF057801AJ	2
31	Needle bearing	ST051100AV	ST051100AV	4
32	5/16"-18 x 1 1/2" Socket head screw	]	]	8
33	Bearing cap	TF202001AH	TF202001AH	1
34	5/16"-18 x 3/4" Set screw	ST070802AV	ST070802AV	6

Ref. No.	Description	Part number for model:		Qty.
		CI150000PP	CI100000PP	
35	Breather tube	TW003600AV	TW003600AV	1
36	1 0.015" Gasket	XA006102AV	XA006102AV	1
	0.024" Gasket (not shown)	XA006103AV	XA006103AV	1
37	Breather mesh	TF064501AV	TF064501AV	1
38	Breather ball	ST094700AV	ST094700AV	1
39	Breather cap	TW003800AG	TW003800AG	1
40	1/4"-20 x 3/8" Set screw	ST064800AV	ST064800AV	1
41	Bearing cup	ST066200AV	ST066200AV	2
42	Bearing cone	ST067000AV	ST067000AV	2
43	Crankshaft w/bearing cones	TX034500AJ	TX034500AJ	1
44	Discharge tube	TX033800AP	—	1
45	Oil level gage	TF050101AV	TF050101AV	1
46	1/4"-18 NPT Drain plug	ST072917AV	ST072917AV	1
47	1/2"-14 NPT Filler plug	ST066400AV	ST066400AV	1
48	Crankcase assembly w/ bearings	TX028000AJ	TX028000AJ	1
49	Oil seal	ST066900AV	ST066900AV	1
50	Flywheel	TX034800AG	PU011100AG	1
51	Washer	TX034600AV	TX034600AV	1
52	Lockwasher	ST071015AV	ST071015AV	1
53	Torque screw	TX034700AV	TX034700AV	1
54	Seal	TF202400AV	TF202400AV	1
55	Oil Pump	TF202100AV	TF202100AV	1
56	Oil filter housing	TF201800AJ	TF201800AJ	1
57	Oil filter	TF202700AV	TF202700AV	1
58	Bolt	ST070808AV	ST070808AV	3
59	Fitting	ST049600AV	ST049600AV	1
60	Oil tube	TX033300AP	TX033300AP	1
61	Pipe tee	ST160600AV	ST160600AV	1
62	Discharge tube	TX032001AP	—	1
63	Discharge tube	TX033500AP	—	1
64	1/4"-20 x 5/8" Screw	ST070668AV	—	4
65	Bracket	TX033100AV	—	2
66	Straight compression fitting	ST072024AV	—	1
67	Intercooler	TX032700AV	—	1
68	90° Elbow	ST072231AV	—	2
<b>REPLACEMENT KITS AND ACCESSORIES</b>				
69	Filter kit (Incl. Ref. #1-5)	TF060503AV	TF060501AV	2
70	Ring kit	TF006900AJ	TF006900AJ	2
71	High pressure piston assembly	TF002300AJ	TF002300AJ	2
72	Low pressure piston assembly	TF002400AJ	TF002400AJ	2
1	Gasket kit	TF061600AJ	TF061600AJ	2
s	†† Threaded air intake adapter (not shown)	TF060502AV	TF060502AV	2
††	Threaded air filter	ST073902AV	ST073902AV	2
(j)	Standard hardware item, available locally.			
(s)	Optional adapter kit provides 1" NPT threads at pump head. Requires piping between pump and filter.			



## Specifications

Motor HP	Volts/Phase	Minimum Circuit	Discharge Pressure	Delivery SCFM	Pump RPM	Oil Capacity	Oil Type
5	230 V / 1 Ø	23 Amps	175 psi	17.1	68.5	2 qts.	ISO 100 (SAE 30) # ST126700AV

### Model CI051089VPMS

#### Dimensions

A	Overall width	33"
B	Boltdown width (120° apart)	27"
C	Overall height	78"
D	Tank outlet to feet	40"
E	Overall depth	26"
F	Isolation pads	3/4"

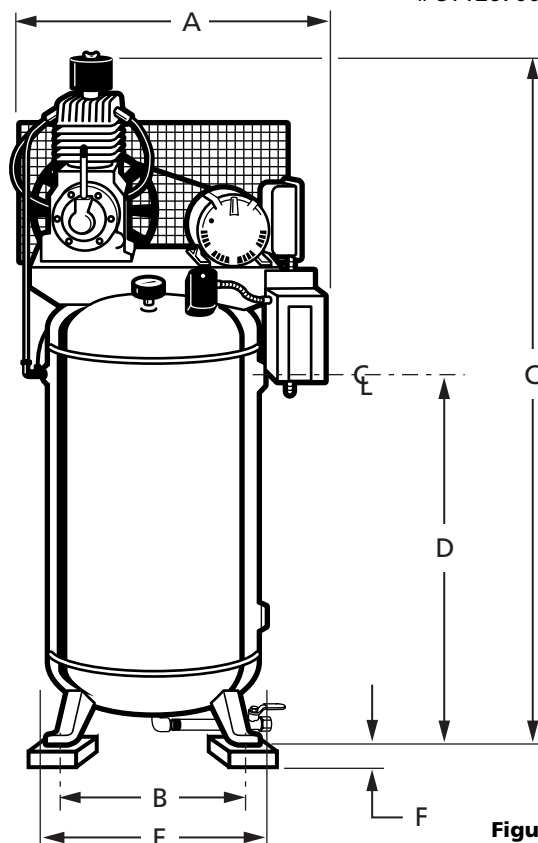

Figure 4

### Replacement Parts List for Compressor Unit

Ref. No.	Description	Part Number	Qty	Ref. No.	Description	Part Number	Qty
1	Air compressor pump	TF310100AJ	1	26	Cap	ST075400AV	4
2	Isolation pads (kit of 3)	ZZ000043AJ	1	27	Hex flange nut	ST116201AV	2
3	Tank	TF006605CG	1	28	Bolt	ST016500AV	2
4	7/16" - 14 x 1½" Hex head screw	ST070645AV	4	29	Washer	ST011200AV	2
5	7/16" Washer	ST070916AV	8	30	1/4" - 20 x 1½" Bolt	ST023400AV	1
6	7/16" - 14 Hex nut	ST036300AV	4	31	1/4" Washer	ST000600AV	1
7	Elbow	ST071212AV	1	32	Beltguard bracket	TF063100AV	1
8	Discharge tube	TF061500AV	1	33	3/4" check valve	CV003205AV	1
9	Nut and ferrule	ST072321AV	1	34	3/4" x 1/4" reducer bushing	ST151000AV	1
10	90° Compression fitting	ST072231AV	1	35	Magnetic starter bracket	BG215300AV	1
11	1/4" Compression fitting	ST011701AV	1	36	Self-threading screw	ST016500AV	2
12	1/4" NPT, 300 PSI pressure gauge	GA016703AV	1	37	Magnetic starter assembly	ST122001AJ	1
13	1/4" - 18 x 2½" Pipe nipple	ST070307AV	1	38	Low oil guard (230V only)	TF062800AJ	1
14	Safety valve	V-215200AV	1	39	Pipe nipple	ST070355AV	1
15	Pressure switch, 145/175	CW207561AV	1	40	Ball valve	ST079802AV	1
16	Copper tube	R-060600AY	2 ft.	Δ	ASME Port o-ring	PG201002AV	1
17	Motor	MC022393AV	1	Δ	ASME Port plug	PG201006AV	1
18	5/16" - 18 x 1/2" Set screw	ST026400AV	2	Δ	O-ring	ST070190AV	2
19	Belt	BT022000AV	1				
20	Pulley	PU008003AV	1				
21	3/8" - 16 x 1¼" Screw	ST070654AV	4				
22	3/8" Washer	ST070914AV	8				
23	3/8" - 16 Nut	ST057600AV	4				
24	Belt guard front	BG217000AV	1				
25	Belt guard back	BG217100AV	1				

(Δ) Not shown.

Unloader valve for pressure switch available separately, part number CW000200AV

Heater element for magnetic starter assembly available separately, part number PS005551AV

# For Replacement Parts, Call 1-888-636-6628

Please provide following information:

- Model number
- Serial number (if any)
- Part descriptions and number as shown in parts list

Address parts correspondence to:

PowerPro  
 Attn: Parts Department  
 100 Production Drive  
 Harrison, OH 45030

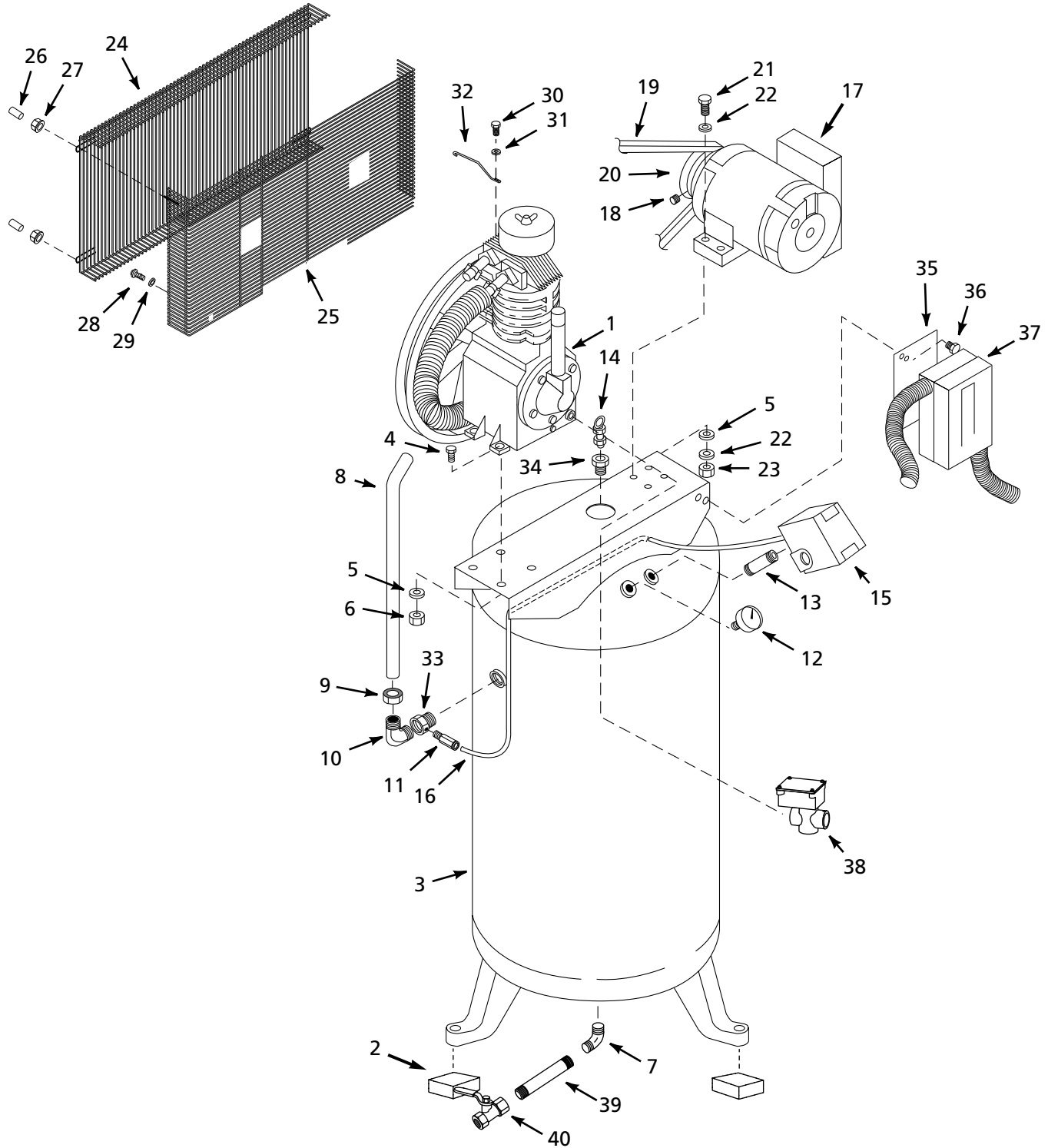

Figure 5

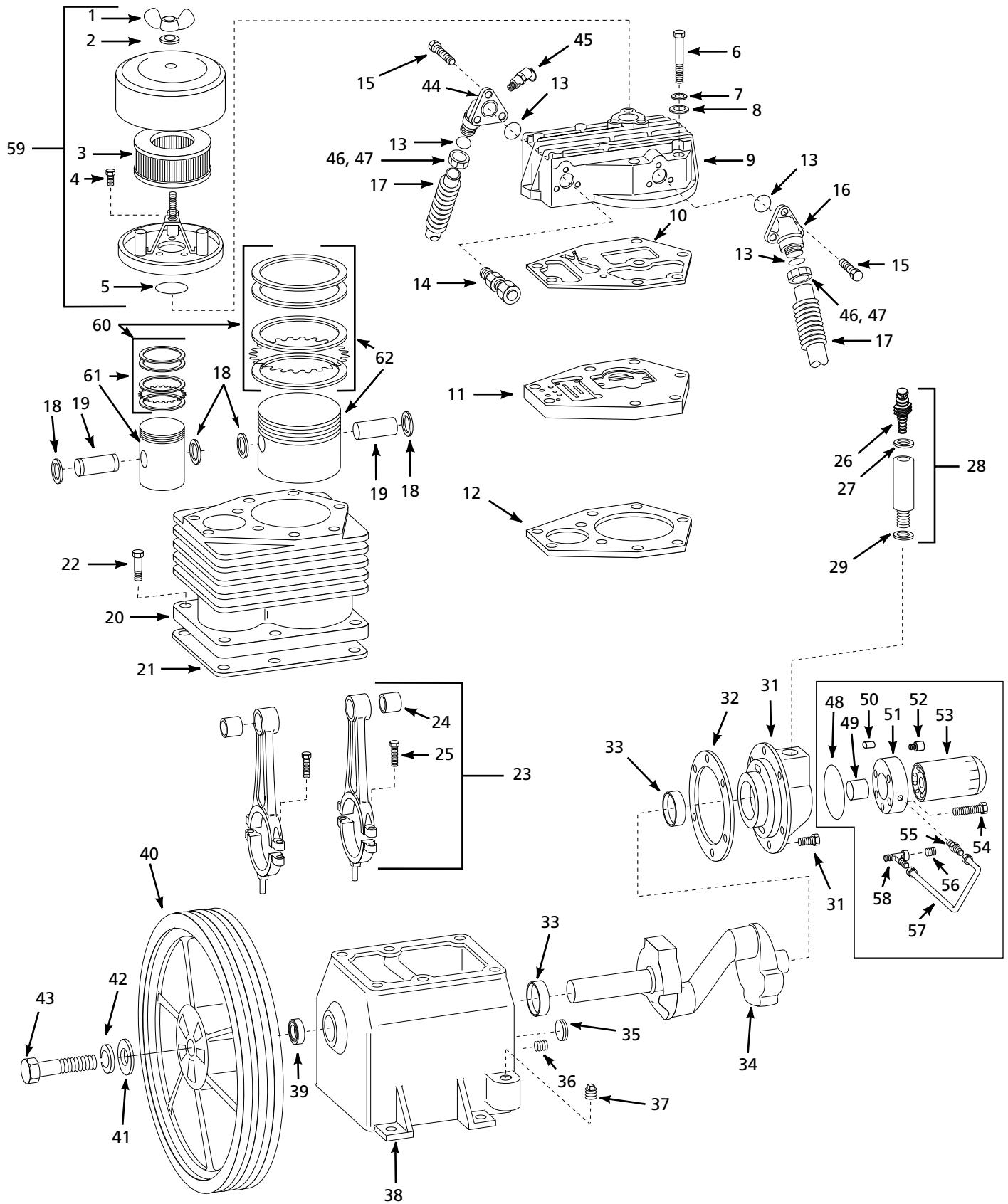

Figure 6

# For Replacement Parts, Call 1-888-636-6628

Please provide following information:

- Model number
- Serial number (if any)
- Part descriptions and number as shown in parts list

Address parts correspondence to:

PowerPro  
 Attn: Parts Department  
 100 Production Drive  
 Harrison, OH 45030

Ref. No.	Description	Part No.	Qty.	Ref. No.	Description	Part No.	Qty.
1	1/4"-20 Wing nut	*	1	37	1/2"-14 NPT Filler plug	ST066400AV	1
2	1/4" Washer	*	1	38	Crankcase assembly	TF050202AJ	1
3	Filter element	TF060504AV	1	39	Oil seal	ST066900AV	1
4	1/4-20 x 1/2" screw	ST074401AV	3	40	Flywheel	PU011106AV	1
5	O-ring	---	1	41	Washer	ST124200AV	1
6	3/8"-16 x 3 1/2" Screw	ST070684AV	9	42	Lockwasher	ST071012AV	1
7	3/8" Bellville washer	ST158100AV	9	43	1/2"-13 Screw	TX034700AV	1
8	3/8" Plain washer	ST057700AV	9	44	Tube fitting	TF060403AJ	1
9	Cylinder head	TF060101AG	1	45	Safety valve	V-208900AV	2
10	1 Head gasket	TF060300AV	1	46	Tube nut	ST072315AV	1
11	Valve plate assembly	TF059700AJ	1	47	Ferrule	TF064400AV	1
12	1 Gasket, cylinder to valve plate	TF061301AV	1	48	Seal	TF202400AV	1
13	1 O-ring	ST070186AV	6	49	Oil Pump	TF202100AV	1
14	1/2" NPT x 3/4" Comp. fitting	ST072025AV	1	50	Drive pins	ST119204AV	1
15	1/4"-20 x 3/4" Screw	ST120200AV	8	51	Oil filter housing	TF201800AJ	1
16	Tube fitting	TF060402AV	1	52	Oil filter reducer fitting	TW013200AV	1
17	Intercooler	TF002000BH	1	53	Oil filter	TF202700AV	1
18	Retaining ring	ST059400AV	4	54	Bolt	ST070808AV	3
19	Piston pin	TF000500AV	2	55	Fitting	ST049600AV	1
20	Cylinder	TF058000AG	1	56	1/4"-18 NPT Drain plug	ST022000AV	1
21	1 Gasket, cylinder to crankcase	XA006200AV	1	57	Oil tube	TF202600AP	1
22	3/8"-24 x 1" Hex head screw	ST067200AV	6	58	Pipe tee	ST160600AV	1
23	Connecting rod assembly	TF057800AJ	2	<b>REPLACEMENT KITS AND ACCESSORIES</b>			
24	Needle bearing	ST051100AV	2	59	Filter kit (Incl. Ref. #1-5)	TF060500AV	1
25	5/16"-18 x 1 1/2" Socket head screw	*	4	60	Ring kit	TF006900AJ	1
26	Breather cap	VT041702AV	1	61	High pressure piston assembly	TF002300AJ	1
27	O-Ring	ST164402AV	1	62	Low pressure piston assembly	TF002400AJ	1
28	Breather tube assembly with cap (Only available as complete assembly)	TF057601AJ	1	1	Gasket kit	TF061600AJ	1
29	O-ring	ST070176AV	1	s	++ Threaded air intake adapter (not shown)	TF060502AV	1
30	16-18 x 3/4" Socket screw	ST070802AV	6	t	++ Threaded air filter kit	ST073902AV	1
31	Bearing cap	TF060900AG	1	(*)	Standard hardware item, available locally		
32	1 0.015" Gasket	XA006102AV	1	(s)	Optional adapter kit provides 1" NPT threads at pump head, Requires piping between pump and filter kit ST073902AV		
33	Ball bearing	ST129200AV	2	(t)	Filter kit required for optional adapter kit TF060502AV		
34	Crankshaft w/bearings	TF053701AJ	1	(++)	Optional		
35	Oil level gage	TF050101AV	1				
36	1/4"-18 NPT Drain plug	ST022000AV	1				

### TORQUE VALUES

Ref No.	Description	Torque
6	3/8"-16 Screw, head	42 ft. lb.
22	3/8"-24 Screw, cylinder	15 ft. lb.
25	5/16"-18 Screw, connecting rod	14 ft. lb.
30	5/16"-18 Screw, bearing cap	14 ft. lb.
43	1/2" Torque screw, flywheel	50 ft. lb.