

**HANDBOOK
OPERATING AND SERVICE
INSTRUCTIONS**

**MANSFIELD & GREEN
PNEUMATIC DEAD WEIGHT TESTER**

MODEL RK – PRESSURE TESTER

**FOR REPAIR AND RECALIBRATION
RETURN TO**



AMETEK®
TEST & CALIBRATION INSTRUMENTS

8600 SOMERSET DR., LARGO, FL 33773

AMETEK

TEST AND CALIBRATION INSTRUMENTS DIVISION
8600 SOMERSET DR., LARGO, FL 33773



Model RK Pressure Tester

TABLE OF CONTENTS

- 1.0 DEAD WEIGHT TESTING INTRODUCTION
 - 1.1 Correction Factors
 - 1.2 Recommended Recertification Procedures
 - 1.3 Material Necessary for Recertification
 - 1.4 Packaging Instructions

- 2.0 MODEL RK PNEUMATIC DEADWEIGHT TESTER
 - 2.1 Model Description
 - 2.2 Assembly and Set Up Instructions
 - 2.3 Operating Instructions
 - 2.4 Maintenance and Trouble Shooting

1.0 DEADWEIGHT TESTING, INTRODUCTION

The deadweight tester is one of the few instruments that can be used to generate pressure in terms of the fundamental units of force and area. Since only the fundamental units of force and area are involved for measurements, the deadweight tester need not be continuously referenced to another pressure instrument for its calibration accuracy. Deadweight testers are thus considered primary laboratory pressure standards.

Construction of deadweight testers varies as to the methods of loading weights, rotating or oscillating the piston to reduce friction, and the design of the piston and cylinder. The Mansfield and Green Pneumatic Dead Weight Testers employ a unique method of operation. Clean, dry air or nitrogen is supplied from a built in flow regulator to an equalizing annulus and from there under the ball to the output port. The ball, with weight hanger and weights, floats on a film of air.

1.1 CORRECTION FACTORS

It is obvious that error in pressure determinations can result from any uncertainty of the mass of the loading weights and from the measurement of the effective area of the ball and nozzle. Other sources of error may not be so easily recognized. Such sources include the air buoyancy of the weights, gravity, thermal expansion and elastic deformation of the ball and nozzle, and the air heads involved. All of these corrections with the exception of local gravity (except when specified), thermal expansion, and air head have been corrected on the testers as shipped by Mansfield & Green.

The following technique is suggested to compute corrected tester output pressure readings:

A. Gravity

The value of local gravity can differ by more than 0.2% at different locations in the United States. As pressure is defined as "force per unit area", the mass values must be converted to force values. To accomplish this, the acceleration of gravity must be used. The acceleration of local gravity may be determined by having a gravitational survey made of the local area with a gravimeter or by contacting the National Oceanic and Atmospheric Administration, U.S. Department of Commerce. Once the local value of gravity is known, the pressure may be corrected using the following equation.

$$P_G = \frac{G}{G_W} \times P_N$$

Where:

- P_G — tester output pressure corrected only for gravity
- G — local gravity
- G_W — gravity value for which the tester is calibrated
- P_N — pressure value of weights applied

B. Temperature

If the coefficient of expansion of the ball and nozzle is positive the effective area will increase with increasing temperature resulting in a corresponding decrease in pressure. Corrections can be made using the following formula.

$$P_T = \frac{P_G}{1 + 1.67 \times 10^{-5} (T - 23^\circ \text{C})}$$

Where

P_T = Tester output pressure corrected for gravity and temperature

T = Ambient temperature ($^\circ\text{C}$)

C. Air Head

When pressurized, a correction is required only when the gage height or reference plane of the unit being calibrated is either higher or lower than that of the pneumatic tester. The reference plane of the pneumatic testers is at the top of the nozzle. Heights above the reference plane are negative, while heights below the reference plane are positive. Corrections can be made using the following formula.

$$P_A = P_T (1 + H \times 2.84 \times 10^{-6})$$

Where

H = Air head (inches)

P_T = Tester output pressure corrected for gravity and temperature

P_A = Tester output pressure corrected for gravity, temperature, air head

SECTION 1.2 RECOMMENDED RECERTIFICATION PROCEDURES

1.0 INTRODUCTION

All deadweight pressure testers produced by AMETEK, MANSFIELD & GREEN PRODUCTS are tested and certified in the M & G laboratory for accuracy of pressure produced, with results traceable to the National Institute of Standards Technology.

This accuracy can degrade with wear resulting from continued use and/or accidental damage. AMETEK, MANSFIELD & GREEN PRODUCTS recommends all instruments be periodically retested for accuracy of pressure produced. Testers returned to AMETEK, MANSFIELD & GREEN PRODUCTS will be "tested and (re)certified for accuracy traceable to NIST" or "tested and (re)certified with data furnished traceable to NIST" if tester is in operable condition.

1.2 FREQUENCY OF RECERTIFICATION

Frequency of recertification of a pneumatic deadweight tester is a precautionary measure that is undertaken by each user to assure that the device is functioning accurately and has

not worn in such a way as to produce inaccurate pressure. Many different factors can contribute to malfunction and wear. No standard period of recertification is appropriate for every application. If the device is used for portable service in dirty or dusty environment, frequent recalibration is appropriate. Infrequently used instruments used only under laboratory conditions need only be calibrated infrequently.

M & G has found that the input flow rate to the tester for specific output pressure is the best measure of operation of the tester. A flow meter capable of reading in Standard Cubic Feet per Hour is placed in the input line prior to the tester. The tester is cycled through several output pressures within the range and the flow rate noted. If the flow rate for a given pressure changes significantly, wear or malfunction is indicated.

Formal recertification should be done at regular intervals by cross-floating the tester within a pressure laboratory. M & G Laboratory can provide actual performance data which includes the effective operating area of the ball as well as the mass of each weight.

M & G suggests that users with unknown history of usage with pneumatic deadweight testers consider conducting flow rate tests monthly and have the testers recertified annually. This annual recertification should include the performance data. As the user accumulates a history of usage and wear, the recertification cycle can be adjusted accordingly.

1.3 MATERIAL NECESSARY FOR RECERTIFICATION

The entire tester and weight set must be returned to M & G for recertification.

1.4 PACKAGING INSTRUCTIONS

All parts returned to M & G must be securely packaged to preclude damage in shipping.

Testers should be returned in their normal cases and the cases packaged to prevent damage in shipping. Weights should be individually packaged in such a manner to preclude shipping damage.

2.0 MODEL RK PNEUMATIC DEADWEIGHT TESTER

2.1 MODEL DESCRIPTION

The Model RK Tester is a self-regulating, primary pressure standard with a pressure capacity to 300 PSIG. This instrument operates on the dead weight principle using only fundamental units of force and area. Pressure equals the weight force divided by the effective area of the ball.

The Model RK Tester contains an integral weight storage compartment for ranges to 50 PSIG or equivalent within the cast metal base which houses the workings of the instrument. An extra weight storage case is provided to house the 50 PSI and 400 KPa weights. This instrument is available with accuracies of .015% (.025% below 1 PSI and .015% at 1 PSI and above) and .025% and .05% of indicated reading with stainless steel weights. Standard model testers and weights supplied with each instrument are tabulated on Table 1.

2.2 ASSEMBLY AND SET UP INSTRUCTIONS

A. BALL and NOZZLE

Check the ceramic ball and the nozzle for cleanliness. Carefully remove the nozzle by pulling it upward while twisting it to overcome the friction of the O ring seal. Cup one hand over the top (beveled end) of the nozzle and push from the bottom of the nozzle to remove the ball.

If the ball tends to stick when being inserted, DO NOT FORCE IT as this may cause serious damage to the nozzle. Never scrape the nozzle and associated parts with a hard object or use anything that is abrasive or that will remove material from the parts. It is recommended that the ball and nozzle be frequently cleaned with a residue free solvent such as freon.

It is also recommended that the ball and nozzle be kept in place at all times, except when necessary for cleaning. This helps to prevent dirt from getting into the ball and nozzle assembly.

B. LEVELING

For proper operation, the tester should be placed on a support that is solid and free from vibration.

Leveling is accomplished by adjusting the two leveling screws on the end of the tester base which is on the operators left when facing the operating valves. The third foot, on the right end of the base, is an adjustable pivot. A bull's eye level is mounted on top of the tester. This level has been carefully adjusted at the factory.

CAUTION: Do not tamper with the setting of this level.

TABLE I - MODEL RK PNEUMATIC DEAD WEIGHT TESTERS

MODEL	RANGE	MINIMUM INCREMENT	WEIGHT SET
RK-100WC-SS	4-104" H ₂ O	1" H ₂ O	Table 2A
RK-300WC-SS	4-314" H ₂ O	1" H ₂ O	Table 2A
RK-600WC-SS	4-614" H ₂ O	1" H ₂ O	Table 2A
RK-1100WC-SS	4-1114" H ₂ O	1" H ₂ O	Table 2A
RK-1600WC-SS	4-1614" H ₂ O	1" H ₂ O	Table 2A
RK-50-SS	1-51 PSI	1 PSI	Table 2B
RK-100-SS	1-101 PSI	1 PSI	Table 2B
RK-200-SS	1-201 PSI	1 PSI	Table 2B
RK-300-SS	1-301 PSI	1 PSI	Table 2B
RK-200N-SS	1-211 kPa	1 kPa	Table 2C
RK-400N-SS	1-411 kPa	1 kPa	Table 2C
RK-800N-SS	1-811 kPa	1 kPa	Table 2C
RK-1200N-SS	1-1211 kPa	1 kPa	Table 2C
RK-2000N-SS	1-2011 kPa	1 kPa	Table 2C
RK-500CM-SS	10-510 CM H ₂ O	10 CM H ₂ O	Table 2D
RK-1000CM-SS	10-1010 CM H ₂ O	10 CM H ₂ O	Table 2D
RK-2000CM-SS	10-2010 CM H ₂ O	10 CM H ₂ O	Table 2D
RK-3000CM-SS	10-3010 CM H ₂ O	10 CM H ₂ O	Table 2D
RK-4000CM-SS	10-4010 CM H ₂ O	10 CM H ₂ O	Table 2D
RK-100H-SS	1-112" HG	0.1" HG	Table 2E
RK-300WC/30-SS	4-314 H ₂ O	1" H ₂ O	Table 2G
	1-31 PSI	1 PSI	Table 2G
RK-2B-SS	.01-2 BAR	.01 BAR	Table 2F
RK-4B-SS	.01-4 BAR	.01 BAR	Table 2F
RK-8B-SS	.01-8 BAR	.01 BAR	Table 2F
RK-12B-SS	.01-12 BAR	.01 BAR	Table 2F
RK-20B-SS	.01-20 BAR	.01 BAR	Table 2F

TABLE 2A - MODEL RK PNEUMATIC DEADWEIGHT TESTER
Pressure in Inches of Water @ 20° C*

MODEL NUMBER	WEIGHT CARRIER & BALL (Inches of H ₂ O)	WEIGHTS FURNISHED PER PRESSURE INCREMENT								
		1" H ₂ O	2" H ₂ O	5" H ₂ O	10" H ₂ O	20" H ₂ O	50" H ₂ O	100" H ₂ O	200" H ₂ O	500" H ₂ O
RK-100WC-SS	4" H ₂ O	1	2	1	9					
RK-300WC-SS	4" H ₂ O	1	2	1	1	2	1	2		
RK-600WC-SS	4" H ₂ O	1	2	1	1	2	1	1	2	
RK-1100WC-SS	4" H ₂ O	1	2	1	1	2	1	1	2	1
RK-1600WC-SS	4" H ₂ O	1	2	1	1	2	1	1	2	2
Part Number	K-2064	K-2067-11	K-2067-2	K-2068-2	K-2068-1	K-2069-8	K-2069-5	K-2060-4	K-2061-3	K-2061-4

* Calibration to 80°F per AGA Standards is available on special order.

TABLE 2B – MODEL RK PNEUMATIC DEADWEIGHT TESTER
Pressure in Pounds per Square Inch

MODEL NUMBER	WEIGHT CARRIER & BALL (PSIG)	WEIGHTS FURNISHED PER PRESSURE INCREMENT					
		1 PSI	2 PSI	5 PSI	10 PSI	20 PSI	50 PSI
RK-50-SS	1 PSI	1	2	1	2	1	
RK-100-SS	1 PSI	1	2	1	2	1	1
RK-200-SS	1 PSI	1	2	1	2	1	3
RK-300-SS	1 PSI	1	2	1	2	1	5
Part Number	K-2066	K-2059-10	K-2059-1	K-2060-6	K-2061-1	K-2065-1	K-2062-4

TABLE 2C – MODEL RK PNEUMATIC DEADWEIGHT TESTER
Pressure in Kilopascals

MODEL NUMBER	WEIGHT CARRIER & BALL (KPa)	WEIGHTS FURNISHED PER PRESSURE INCREMENT								
		1 KPa	2 KPa	5 KPa	10 KPa	20 KPa	50 KPa	100 KPa	200 KPa	400 KPa
RK-200N-SS	1 KPa	1	2	1	1	2	1	1		
RK-400N-SS	1 KPa	1	2	1	1	2	1	1	1	
RK-800N-SS	1 KPa & 2 KPa	1	2	1	1	2	1	1	1	1
RK-1200N-SS	1 KPa & 2 KPa	1	2	1	1	2	1	1	1	2
RK-2000N-SS	1 KPa & 2 KPa	1	2	1	1	2	1	1	1	4
Part Number	K-2067-2	K-2064-3	K-2058-3	K-2059-2	K-2059-3	K-2060-1	K-2061-5	K-2061-6	K-2065-2	K-2062-3

TABLE 2D – MODEL RK PNEUMATIC DEADWEIGHT TESTER
Pressure in Centimeters of Water @ 20° C

MODEL NUMBER	WEIGHT CARRIER & BALL (CM. of H ₂ O)	WEIGHTS FURNISHED PER PRESSURE INCREMENT							
		10 CM H ₂ O	20 CM H ₂ O	50 CM H ₂ O	100 CM H ₂ O	200 CM H ₂ O	500 CM H ₂ O	1000 CM H ₂ O	
RK-500CM-SS	10 CM H ₂ O	1	2	1	1	2			
RK-1000CM-SS	10 CM H ₂ O	1	2	1	2	1	1		
RK-2000CM-SS	10 CM H ₂ O	1	2	1	2	1	1	1	
RK-3000CM-SS	10 CM H ₂ O	1	2	1	2	1	1	2	
RK-4000CM-SS	10 CM H ₂ O	1	2	1	2	1	1	3	
Part Number	K-2064-1	K-2068-4	K-2058-4	K-2059-6	K-2059-7	K-2060-5	K-2061-8	K-2061-9	

TABLE 2E – MODEL RK PNEUMATIC DEADWEIGHT TESTER
Pressure in Inches of Mercury @ 20° C

MODEL NUMBER	WEIGHT CARRIER & BALL (CM. of H ₂ O)	WEIGHTS FURNISHED PER PRESSURE INCREMENT								
		.1" Hg	.2" Hg	.5" Hg	1" Hg	2" Hg	5" Hg	10" Hg	20" Hg	50" Hg
RK-300H-SS	1" Hg	1	2	1	1	2	1	1	2	1
Part Number	K-2070	K-2057-4	K-2057-9	K-2058-5	K-2058-5	K-2059-4	K-2060-2	K-2060-3	K-2061-2	K-2065-3

TABLE 2F – MODEL RK PNEUMATIC DEADWEIGHT TESTER
Pressure in BARS

MODEL NUMBER	WEIGHT CARRIER & BALL (BARS)	WEIGHTS FURNISHED PER PRESSURE INCREMENT								
		.01 BAR	.02 BAR	.05 BAR	.10 BAR	.20 BAR	.50 BAR	1.0 BAR	2.0 BAR	4.0 BAR
RK-2B-SS	.01 BAR	1	2	1	1	2	1	1		
RK-4B-SS	.01 BAR	1	2	1	1	2	1	1	1	
RK-8B-SS	.01 BAR	1	2	1	1	2	1	1	1	1
RK-12B-SS	.01 BAR	1	2	1	1	2	1	1	1	2
RK-20B-SS	.01 BAR	1	2	1	1	2	1	1	1	4
Part Number	K-2064-2	K-2068-3	K-2058-3	K-2059-2	K-2059-3	K-2060-1	K-2061-5	K-2061-6	K-2065-2	K-2062-3

TABLE 2G – MODEL RK PNEUMATIC DEADWEIGHT TESTER
Pressure Ranges in Inches of Water at 20° C and Pounds per Square Inch

MODEL NUMBER	WEIGHT CARRIER & BALL (Inches of H ₂ O)	WEIGHTS FURNISHED PER PRESSURE INCREMENT						
		1" H ₂ O	2" H ₂ O	5" H ₂ O	10" H ₂ O	20" H ₂ O	50" H ₂ O	100 H ₂ O
RK-300WC/30SS	4" H ₂ O	1	2	1	1	2	1	2
Part Number	K-2064	K-2057-1	K-2068-4	K-2064-2	K-2068-1	K-2059-8	K-2059-5	K-2060-4
		1 PSI	2 PSI	5 PSI	10 PSI			
RK-300WC/30SS	1 PSI	1	2	1	2			
Part Number	K-2066	K-2059-10	K-2059-1	K-2060-6	K-2061-1			

TABLE 2H
SPECIAL ALUMINUM LOW PRESSURE WEIGHT SETS

WEIGHT SET NUMBER RWS-0.1 WC Part No.	WEIGHTS FURNISHED IN PRESSURE INCREMENTS (IN/H ₂ O)				
	.9" H ₂ O	.8" H ₂ O	.7" H ₂ O	.6" H ₂ O	.5" H ₂ O
	Qty: 1	Qty: 1	Qty: 1	Qty: 1	Qty: 1
	K-2063-7	K-2063-6	K-2063-5	K-2063-4	K-2063-11
WEIGHT SET NUMBER RWS-0.1 P.S.I. Part No.	WEIGHTS FURNISHED IN PRESSURE INCREMENTS (PSI)				
	.5 P.S.I.	.2 P.S.I.	.1 P.S.I.		
	Qty: 1	Qty: 2	Qty: 1		
	K-2068-8	K-2068-1	K-2067-13		
WEIGHT SET NUMBER RWS-1CM Part No.	WEIGHTS FURNISHED IN PRESSURE INCREMENTS CM/H ₂ O				
	5 CM/H ₂ O	2 CM/H ₂ O	1 CM/H ₂ O		
	Qty: 1	Qty: 2	Qty: 1		
	K-2069-1	K-2063-8	K-2063-3		
WEIGHT SET NUMBER RWS-0.1 kPa Part No.	WEIGHTS FURNISHED IN PRESSURE INCREMENTS (kPa)				
	.5 kPa	.2 kPa	.1 kPa		
	Qty: 1	Qty: 2	Qty: 1		
	K-2069-2	K-2063-2	K-2063-1		
WEIGHT SET NUMBER RWS-.001 BAR Part No.	WEIGHTS FURNISHED IN PRESSURE INCREMENTS (BAR)				
	.005 BAR	.002 BAR	.001 BAR		
	Qty: 1	Qty: 2	Qty: 1		
	K-2069-2	K-2063-2	K-2063-1		

TABLE 21 — MODEL RK PNEUMATIC DEADWEIGHT TESTER
Pressure in Kg/cm²

MODEL NUMBER	WEIGHT CARRIER & BALL - Kg/cm ²		WEIGHTS FURNISHED PER PRESSURE INCREMENT								
			.01 kg/cm ²	.02 kg/cm ²	.05 kg/cm ²	.1 kg/cm ²	.2 kg/cm ²	.5 kg/cm ²	1 kg/cm ²	2 kg/cm ²	4 kg/cm ²
RK-4M-SS	.01 Kg/cm ²	--	1	2	1	1	2	1	3	-	-
RK-8M-SS	--	.02 Kg/cm ²	1	2	1	1	2	1	3	-	1
RK-20M-SS	.01 Kg/cm ²	.02 Kg/cm ²	1	2	1	1	2	1	1	1	4
PN	K-2064-3	K-2067-3	K-2069-7	K-2068-7	K-2069-14	K-2069-13	K-2060-7	K-2061-10	K-2061-7	K-2065-6	K-2062-5

C. CONNECTION

Connect a supply of instrument quality air or nitrogen per ISA Quality Standard 7.3 "Quality Standard for Instrument Air" to the connection marked "Inlet". Use of gases with other density will affect the accuracy of the tester. Gases used with the tester must also be compatible with the materials used for construction. M & G can assist users, on request, to evaluate alternate gases.

When using the tester through the full range, control the supply pressure to 50 PSI minimum but not to exceed 450 PSI. For special applications, the supply pressure should be set at a value which is at least 50% greater than the required maximum output pressure of the tester. For example, if the tester is used to produce an output pressure of 100 PSI, the supply pressure should be at least 150 PSI. At no time should the supply pressure be below 50 PSI.

Connect the instrument to be tested to the connection marked "Output". The tester input and output connections are 1/8" NPT female. The user can attach adapter fittings to convert the tester to any convenient instrument quality fittings.

The accuracy of this tester is seriously undermined by leaks in the output connections and/or the instrument being calibrated. To check, load the tester so as to apply a pressure to a pressure indicating instrument and then, closing the tester output valve. If the pressure indicated by the instrument being calibrated (or auxiliary gauge) is retained, it is safe to assume there are no leaks. If the indicated pressure degrades, a leak is indicated.

CAUTION

Under no circumstances should any mercury or corrosive fluids be permitted to get into the tester. When the tester is used in connection with an instrument or pressure system that contains a liquid, a suitable safeguard such as a trap or float type manometer check valve should be installed in the tester output line to prevent fouling of tester components.

2.3 OPERATING INSTRUCTIONS

- A. Connect a suitable supply line to the fitting marked "inlet" and admit a regulated pressure of at least 50 PSIG and no greater than 450 PSIG. The inlet valve should be in the "off" position until an output pressure is desired.

- B. For pressures below 100 PSIG the inlet valve should be in the "low pressure" position. In the "off" position, there will be no output pressure. For pressures above 100 PSIG the inlet valve should be in the "high" pressure position.
- C. With the inlet valve on the low pressure setting and the output valve in the "off" position, place the weight carrier over the ball. For a standard Inches of Water, Centimeters of Water and Kilopascal testers, the weight carrier will produce the specified output pressure. For standard PSI and Inches of Mercury tester, the converter ring is placed over the weight carrier to produce the specified output pressure.
- D. With the valves set in the above positions and the above weights installed, the ball will float supporting the weights. In this position the output pressure will be 1 PSIG. It is not necessary to spin the weights of the Air Dead Weight Tester to overcome friction. Excessive rotary motion may affect the accuracy of the instruments.

After the tester is set up the weights may be given a slow rotary motion. Weights should rotate freely without abrupt stopping if everything is in proper order. If this is not the case, see par. C. of Section 2A "Maintenance". DO NOT SPIN THE WEIGHTS UNLESS THE BALL IS FLOATING.

- E. Turn the tester outlet valve to the "Output" position. The instrument to be tested is now being pressurized.

CAUTION: It is necessary for the tester to fill the internal cavity of the instrument and the connection lines with pressure before any calibration can be started. The tester ball and weights will fall during this filling phase, but will rise to the operating level after the filling is completed.

- F. If a zero PSIG output pressure is desired for calibration purposes it may be obtained by putting the output valve in the "vent" position. This allows all pressure downstream of the tester to be vented. The tester internal pressure will not be vented.

2.4 MAINTENANCE AND TROUBLE SHOOTING

- A. Cleaning the output restriction: Remove, from under the ceramic ball, with a screw driver. Use a 1/32" drill or a piece of 22 gauge wire to clear out any obstruction.
- B. Clearing the tester of liquid:
 1. Remove the weights and weight carrier from the tester, leaving the ball in place.
 2. Connect an air supply to the tester.
 3. Disconnect the output line.
 4. Open both valves.
 5. While holding the ball from falling out, tilt the tester back so that the output connection is pointing downward.
 6. Pressure the ball into its socket to provide an output of pressure sufficient to purge the tester.
 7. Clean the ball, nozzle and nozzle body thoroughly.

C. Correcting for poor rotation of weights:

1. Check cleanliness of ball and nozzle as described in Section 2.2a.
2. Make sure tester is properly leveled.
3. Isolate tester from environmental vibrations or relocate tester.
4. Check for adequate air supply.

D. The accuracy of this tester is seriously undermined by leaks in the output connections and/or instrument being calibrated. The following test procedures are recommended to assure leak free operation.

1. Leaks in output connections

Load the tester so as to apply a pressure to the instrument being calibrated. Close the tester output valve.

If pressure indicated by instrument being calibrated holds, it is safe to assume there are no leaks between the tester and instrument.

2. Leaks internal within tester

Place 5/16" O.D. O ring under the ball in the spherical socket of the cylinder core (Caution: do not cover the output restriction).

Raise nozzle vertically on the core a distance equal to the O ring cross section.

Replace ball in nozzle, place carrier on ball and load carrier with weights for maximum tester output pressure.

Close tester inlet valve.

If pressure indicated by the instrument being calibrated holds, it is safe to assume no leaks within the tester.

WARNING

Leak check should be done in the order described, otherwise the source may not be accurately identified.

DO NOT ATTEMPT TO REPAIR INTERNAL LEAKS. RETURN THE TESTER TO AMETEK, MANSFIELD & GREEN PRODUCTS FOR REPAIR OR THE WARRANTY IS VOID.

E. Replacing the Nozzle O Ring

Remove the ball and nozzle and the nozzle O ring (10-90181). The replacement O ring should be wiped clean with a lint free cloth and placed within the groove in the nozzle body. Do not lubricate the O ring with any oil or grease. Clean the ball and nozzle as described in Section 2.2a and reassemble.

2.5 ILLUSTRATED PARTS BREAKDOWN

The Model RK Tester is carefully tested for both internal leakage and accuracy of output pressure prior to shipping from Mansfield and Green. No internal adjustments and/or alterations may be made or the Warranty is voided. If the tester is malfunctioning and the external adjustments described in Section 2.4 do not cure the problem, it must be returned to Mansfield and Green for repair.

The Illustrated Parts Breakdown for the Model RK Tester is shown on Figure 1.

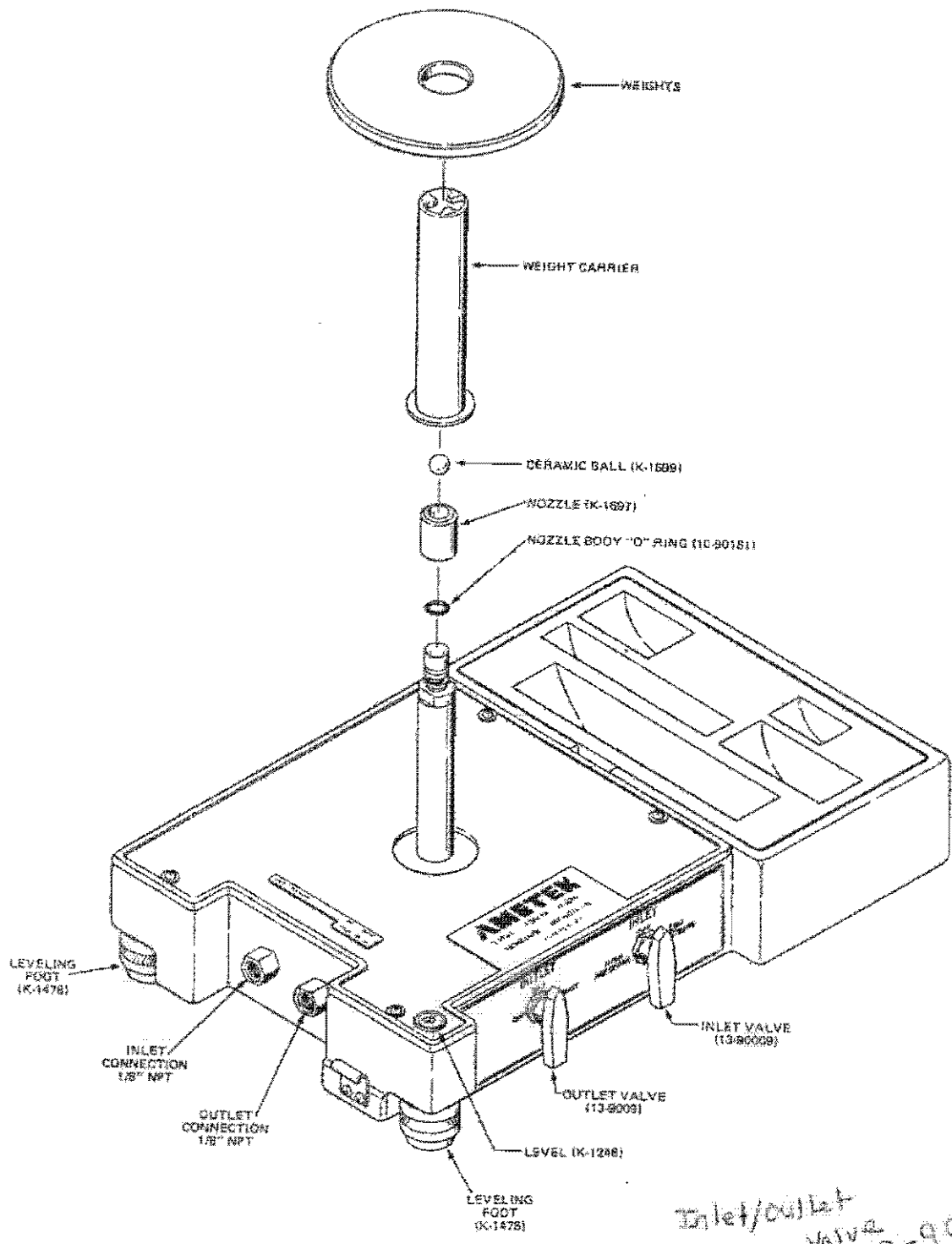

METEK

U.S. GAUGE DIVISION • MANSFIELD & GREEN PRODUCTS • 8600 SOMERSET DR., LARGO, FL 33773

CODE IDENT NO.	REVISIONS	DATE	APPROVED	PNEUMATIC PRESSURE TESTER ILLUSTRATED PARTS BREAKDOWN FIGURE I
92456				