

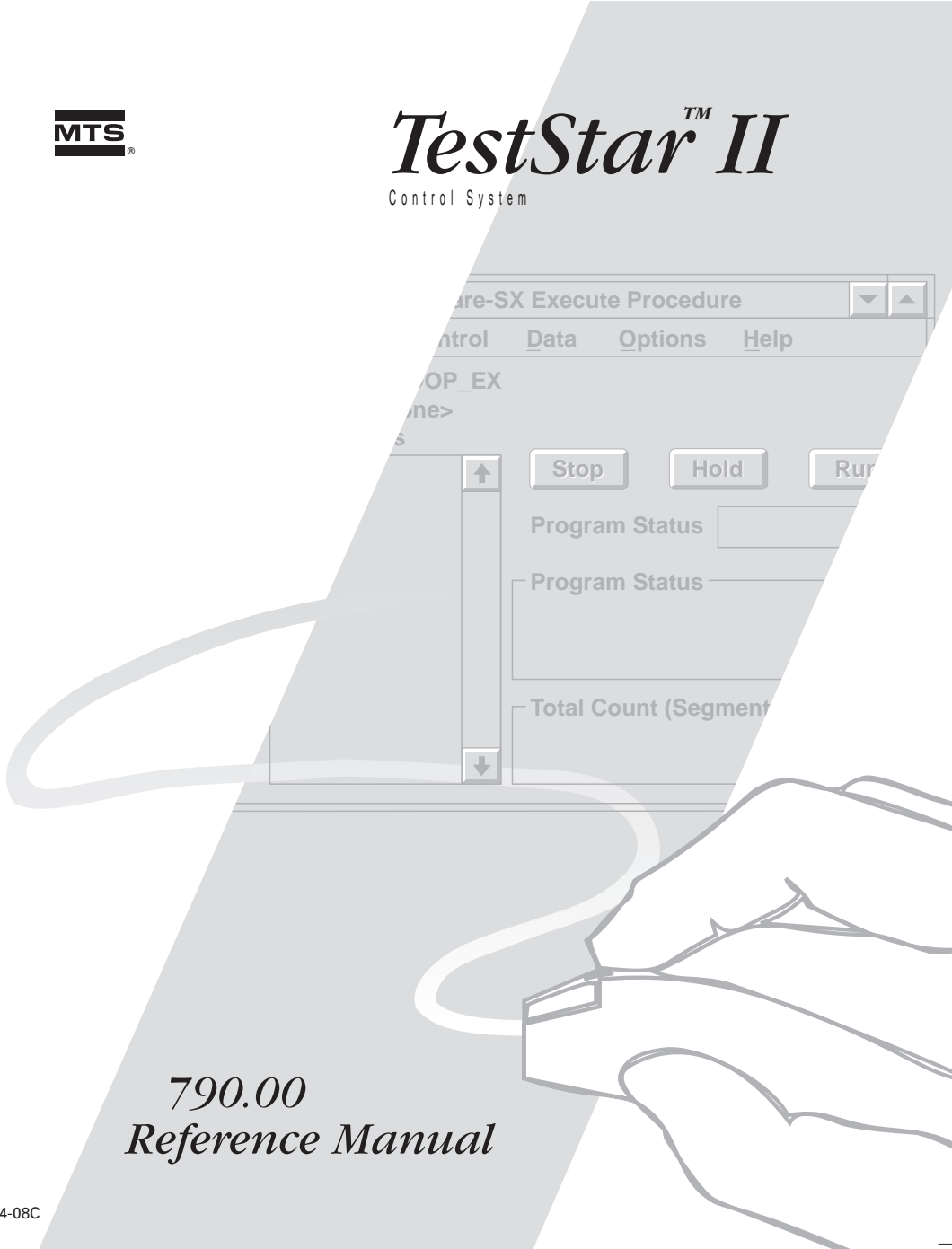

TestStarTM II

Control System



*790.00
Reference Manual*

Proprietary data

This manual, and the software it describes, are both copyrighted, with all rights reserved. Under the copyright laws, neither this manual nor the software may be copied, in whole or part, without written consent of MTS Systems Corporation, except in the normal use of the software or to make a backup copy of the software. The same proprietary and copyright notices must be affixed to any permitted copies as are made for others, whether or not sold, but all of the material purchased (with all backup copies) may be sold, given, or loaned to another person. Under the law, copying includes translating into another language or format. This software may be used on any computer, but extra copies cannot be made for that purpose.

Copyright information

© 1997 MTS Systems Corporation. All rights reserved.

Trademark information

MTS is a registered trademark of MTS Systems Corporation.
TestStar and TestWare-SX are trademarks of MTS Systems Corporation.
IBM and OS/2 are registered trademarks of International Business Machines.
Microsoft and Windows NT are registered trademarks of Microsoft Corporation.

Publication information

The following is the history of this manual.

SOFTWARE RELEASE	MANUAL NUMBER	PUBLICATION DATE
Release 1.1A	150194-01A	April 1991
Release 1.2A	150194-02A	September 1991
Release 1.3A	150194-02B	February 1992
Release 1.4A	150194-03A	July 1992
Release 2.0A	150194-04A	December 1993
Release 2.0B	150194-05A	April 1994
Release 3.0A	150194-06A	January 1995
Release 3.1A	150194-07A	September 1995
Release 3.1A	150194-07B	January 1996
Release 4.0A	150194-08A	October 1996
Release 4.0C	150194-08B	May 1997

Table of Contents

Preface 9

Other Manuals	10
Safety Precautions	11
General Safety Guidelines	12
Safety Guidelines to Follow While Operating the Equipment	15
Load Units and Other Crush Point Hazards	16
Avoiding Hazardous Actuator Movement	17
Guidelines For Installing Specimens	19
Checking the Hardware Setup	20
Installation and Modification Guidelines	21
Supervising the System	22
The Importance of Proper Maintenance	23
Hazard Conventions Used in This Manual	25
How to Obtain Technical Assistance	26
What to Expect When You Call	27

Chapter 1 Introduction 33

How to Use This Manual	34
Window Controls	37
Abbreviations	45
Introducing the TestStar Software	46
Starting TestStar	48
Main TestStar Window	49
Using TestStar Configuration Files	50
Using the Fault Status Window	52
Clearing a Detector	54
Clearing an Interlock	56
Using On-line Help	59
Using the Load Unit Control Panel	61
Main Module Controls and Indicators	62
Control Channel Modules	66

Chapter 2 File Menu 71

Open Window	72
Save Window	74
Select Font Window	76
Print Preview Window	77

Chapter 3 Edit Menu 83

Input Signals	85
Edit Input Signals Window	88
AC & DC Conditioner Signal Type	90
External Signal Types	91
Calculation Signal Types	93
Assign Sensor Window	96
Define External Sensor Window	97
Output Signals	99
Edit Output Signals Window	101
Analog Bus	103
Readout	105
Programmable Output	109
Control Channels	110
Edit Control Channels Window	112
Control Modes	116
Edit Control Modes Window	117
PIDF Control Mode	118
Channel Limited Channel Control Mode	120
Cascade Control Mode	121
Calculation Constants	122
Detector Actions	124
Edit Detector Actions Window	126
Hold Actions	127
Ramp Actions	128
Load Path Stiffness	129
Edit Load Path Stiffness Window	130
LUCP Display	131
Toolbar	133
Configure Toolbar Window	134
Meters	136
Meter Definition Window	137
Timed Data	138

- Peak/Valley Data 139
- Span/Mean Data 140
- Max/Min Data 141
- Scope 142

Chapter 4 Adjust Menu 147

- Input Signals 148
 - Adjust Input Signals Window 149
 - Set Zero Scroll Range Window 156
 - Shunt Cal Window 157
- Tuning 159
 - Tune PIDF Window 161
 - Auto Tuning 163
 - Tune CLC Window 164
 - Tune CASC Window 167
 - Set Scroll Range Window 169
- Adjust Compensators 170
 - Error Detectors 174
- Underpeak Detectors 177
- Adjust Drive 180
 - Adjusting 252 and Dual 252 Valves 181
 - Adjusting 256 and 257 Valves 184

Chapter 5 Display Menu 189

- Display Input Signals 190
- Display Detector Actions 193
 - Display Meters 196
- Display Scope 198
 - Set Scroll Range Window 200
 - Scope Display Options Window 201

Chapter 6 Function Generator 205

- Function Generator Window 206
 - Set Mean Scroll Range 211
 - Set Amplitude Scroll Range 212
 - Set Frequency Scroll Range 213
- Command Menu Options Window 214
- Count Menu Option Window 220
- Home Menu Option Window 222
- Designing a Test Program 224

Chapter 7 System Administration 231

- System Administration Window 233
 - New/Edit User Window 235
 - Application Access Window 237
 - New/Edit Application Window 238
 - User Access Window 239
- Creating a New User 240

Chapter 8 Unit Assignment Set Editor 245

- Unit Assignment Set Editor Window 248
 - Open Unit Assignment Set Window 250
 - Save Unit Assignment Set Window 251
 - Delete Unit Assignment Set Window 252
 - Assign Default Unit Assignment Set Window 253
- Defining a Unit Assignment Set 254

Chapter 9 Tuning 259

- About Tuning 260
 - About Control Modes 265
 - About the Tuning Controls 270
 - About the Tuning Program 274
 - About the Servovalve 276
 - About Specimens 277
 - Monitoring Waveforms 278
- Auto-tuning 281
 - Auto Tuning the First Control Mode 283
 - Auto Tuning Additional Control Modes 285
- Tuning Procedure 288

Appendix 294

- Firmware Error Codes 295
- Digital Controller Error Codes 303
- Servo Loop Update Rate 309
- Debug Options 311
 - Debug Options Window 312
 - Select Output Log File Window 313
- Bypassing the Login 315
- Load Path Stiffness Editor 317
 - Using the Load Path Stiffness Editor 319

Index 323

Preface

Note While the formal name for this product is TestStar II, throughout this manual we use TestStar and TestStar II interchangeably.

What this manual does

This manual provides detailed information about TestStar windows and menus. It is intended to serve as a continuing reference when you need to know detailed information about a specific subject. This manual also includes references to other chapters or manuals where related information may be found.

What this manual does not do

This manual does not provide detailed operating instructions to run a test. It is your responsibility to ensure that all test methods you use are accurate and safe.

What you need to know

TestStar is available for both IBM OS/2 and Microsoft Windows NT operating systems. You need to have a reasonable knowledge of your operating system before attempting to use this manual. You should know how to open and close windows, manage files, and so on.

- ◆ TestStar Version 3.1 use Operating System/2™ (OS/2®), Warp 3.0.
 - ◆ TestStar Version 4.0 and newer use Microsoft® Windows NT®.
-

Who should use this manual

This manual is designed for anyone who wants detailed information about any TestStar feature and functions.

Other Manuals

This manual is part of a set of TestStar manuals that describe TestStar (which is a part of a complete testing system). The following describe the TestStar, TestWare®-SX, and MTS system manuals.

- ◆ The **TestStar Installation Manual** (p/n 150194-xxx) describes how to install TestStar and how to use the utility programs such as sensor calibration, and system administration to establish the initial data base.
- ◆ The **TestWare®-SX Application Manual** (p/n 150197-xxx) describes a general purpose application for TestStar. This includes function generation, data acquisition, event detection, and external control features.
- ◆ The optional **C Programming Reference Manual** (p/n 150195-xxx) describes how to interface with TestStar using a high-level programming language.
- ◆ The **Product Information Manual** contains tabbed sections that describe the hardware components included with your system, such as your load unit and grips. This manual is primarily about hydro-mechanical products.
- ◆ The **Assembly Drawings Manual** contains tabbed sections that contain engineering drawings and part lists of many of the hardware components covered in the Product Information manual. This manual helps you to service your equipment and is useful for MTS Service Engineers if they service your equipment.
- ◆ The optional **TestStar A to Z** manual (p/n 150371-xxx) is an encyclopedia of testing. It describes testing terminology, concepts, and topics—from Actuators to Zeroing sensors.
- ◆ You may also have other manuals for components included with your system that are not manufactured by MTS, such as a printer manual or video monitor manual.

Safety Precautions

WARNING

Improper system installation, operation, or maintenance can result in hazardous conditions that can cause severe personal injury or death, and damage to equipment or a specimen.

Read these Safety Precautions before you use the equipment.

It is very important that you remain aware of hazards that apply to your test system. These Safety Precautions describe hazards that apply to your test system, and offer suggestions for avoiding hazards.

Overview

This chapter contains general operating safety techniques and precautions for operators of materials test systems.

Because each test system is configured for a unique application and operates within a unique environment, it is important to review these guidelines while considering your test system to ensure that the specific operating environment and operating procedures do not result in hazardous situations. Although complete elimination of hazards may not be possible, use the following guidelines to identify hazards so that appropriate training, operating procedures, and safety equipment can be set up.

Common sense and a thorough knowledge of a specific system's operation and capabilities usually suggest the appropriate approach to system operation safety. Therefore, proper safety practices should begin with operator training. Operators should have had prior schooling and training on similar systems. (MTS has training classes that cover servo-hydraulic operating theory, system operating procedures, and system maintenance techniques.) In addition, you should gain an understanding of system functions by studying the various instructions and manuals supplied with the test system.

General Safety Guidelines

Preface

The following safety guidelines are applicable to most test systems. As you read each item listed below, consider how it applies to your system. This can help to produce safer operating practices. If you have any questions, contact an MTS representative.

Know safety placards, read the manuals

Locate, read, and follow all instructions on equipment safety placards. Placard location is typically described in the installation section of the hydro-mechanical product manuals.

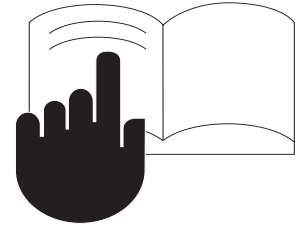

Know emergency stops

Know where all of the system **Emergency Stop** buttons are located so that you can stop the system quickly. **Emergency Stop** buttons have striping like the sample shown here.



Know potential crush points

Know where the potential load unit pinch and crush points are and take appropriate safety precautions. Refer to the discussion on crush point hazards.

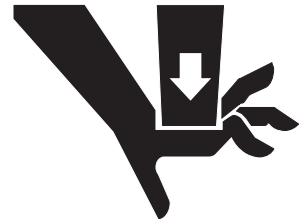

Know system interlocks

System interlock devices should always be used and properly adjusted as described in this manual. Test all interlock devices for proper operation immediately before a test. Never rely on interlock devices to protect you. These devices are designed to minimize the chances of accidental damage to test specimens or to equipment.

Do not bypass the interlock chain

Do not use any interlock reset to bypass the interlock chain while attempting to start the hydraulic power supply. Doing this could cause the hydraulic pressure to be applied regardless of the interlock condition.

Do not disturb sensors

Do not bump, wiggle, adjust, disconnect, or otherwise disturb a sensor (e.g., an extensometer) when hydraulic pressure is applied and the system is operating under control from that sensor.

Ensure secure cable connections

Do not change any cable connections with electrical power or hydraulic pressure applied. Changing cable connections with the system operating can result in an open control loop condition. An open control loop condition can cause rapid unexpected system response resulting in severe personal injury or death or damage to equipment. Also ensure all cables are connected if you make any changes in the system configuration.

Stay Alert

Avoid long periods of unvarying or monotonous work tasks that can contribute to accidents and hazardous situations. Familiarity with the working environment can lead you to overlook potential hazards in that environment.

Stay clear of moving equipment

Keep clear of moving mechanical linkages. Also stay clear of connecting cables and hoses that move along with the specimen or equipment. Objects may get tangled or dragged along with moving equipment. Serious injury can be inflicted by very high forces that can be produced. These forces could pinch, cut, or crush anything in the path of the moving equipment.

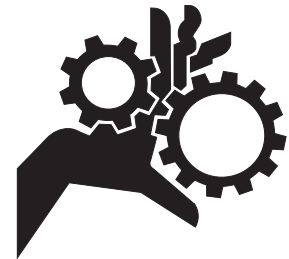
**Be aware of electrical hazards**

To minimize potential electrical shock hazards while the system electrical power is turned on, avoid touching exposed wiring or switch contacts.



Use eye protection

Use adequate eye protection when working with high-pressure hydraulic fluid or explosive specimens, and in circumstances during which anything peculiar to the specimen setup could break apart and cause eye injury.

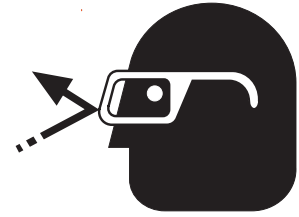

Have first aid available

Accidents happen even to careful people. Arrange scheduling so that a properly trained person will be close by at all times to render first aid.

Practice good housekeeping

Keep work area floors clean. Hydraulic fluid spilled on any type of flooring results in a dangerous, slippery surface.

Keep bystanders away

Keep bystanders at a safe distance from all equipment. Never allow bystanders to touch specimens or equipment while the test is running.

Wear proper clothing

Do not wear neckties, shop aprons, loose clothing, or long hair that could get caught in equipment and create a potentially injurious situation.

Safety Guidelines to Follow While Operating the Equipment

- | | |
|--|--|
| Know proper system operation | Do not make mechanical or electrical adjustments to system components unless you know exactly how the adjustment will affect system operation. Consult your MTS representative when in doubt about any adjustment procedure. |
| Know results of using system controls | Do not make any unnecessary adjustments during operation of the system. To avoid erratic or unexpected system response, do not make any adjustments while the system is operating unless specifically instructed to do so. |
| Know crosshead lift and lock controls | Unlock the crosshead only with high hydraulic pressure applied. Do not adjust the lift controls when the crosshead is locked. |
| Know when to turn on hydraulics | Turn off hydraulic power except for those times that it is necessary for specimen setup or to run the test. Do not have hydraulic power on when making changes to the system configuration. |
| Know system control electronics | Have a thorough knowledge of the control electronics before turning on hydraulic power. Always follow the recommended operational procedures to turn on hydraulic power—failure to do so can cause the actuator to move rapidly and unexpectedly. |
| Know system hydraulic configuration | Some test sites have multiple test stations served by one hydraulic power supply. Understand how these units are interconnected before turning on hydraulic power. |
| Check system cabling | Check the cabling to the system sensors and servovalve. If the feedback or servovalve signal is lost for any reason (such as the connector coming loose or not connected, or the cable is damaged), the resulting signal loss will cause the actuator piston to move at maximum force and maximum velocity until it reaches a mechanical limit. Anything in its path (including you) could be crushed. |
| Make a trial run | Before operating the system for the first time, make a trial run through the desired test by locating the window controls involved without actually performing the adjustment or turning on hydraulic power. |

Load Units and Other Crush Point Hazards

It is especially important to stay clear of any potential crush points when the system is operating. Know where the crush points are in your system and protect yourself and others from those crush points with appropriate safety devices. The following paragraphs describe crush points and precautions to take while working around crush points. These paragraphs apply to most testing and production systems.

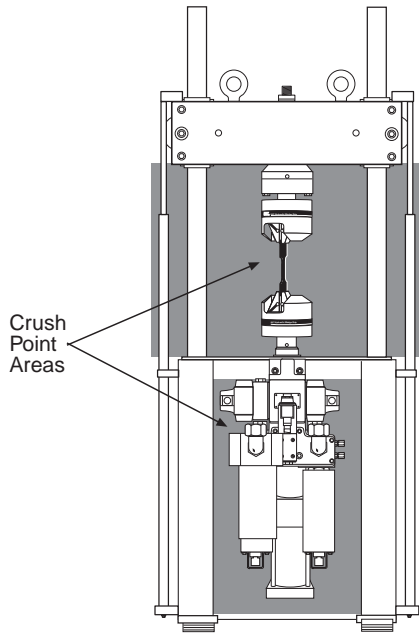

- ◆ Keep clear of any mechanical linkage that moves within a closed area. If the linkage should move (when the system starts or due to mechanical failure), very high forces can be present that could pinch, cut, or crush anything in the path of linkage movement.
 - ◆ Never allow any part of your body to enter the path of machine movement or to touch moving machinery, linkages, hoses, cables, specimens, etc. These present serious crush points or pinch points.
 - ◆ A crush point exists between the platen and crosshead on load units where the actuator piston rod and specimen move. Another potential crush point exists where the lower end of the actuator piston rod extends below the platen and the bottom of the load unit/load frame.
-

Avoiding Hazardous Actuator Movement

The high forces and rapid motions that are usually present in testing systems can produce destructive forces from unexpected or uncontrolled actuator response.

CAUTION

Several things can cause unexpected actuator movement.

The possible combinations of system hardware and software settings make it impossible to predict conditions that produce unexpected actuator movement.

Some conditions can cause an actuator to slam to its mechanical limit, smashing anything in its path. Some conditions can cause an actuator to react so slowly to a command it may appear not to be working. And some conditions can cause the actuator to dance in an unstable fashion while making an obnoxious noise.

Following are safety precautions for you to take:

- ◆ If the control mode feedback signal is interrupted during operation (e.g., if a sensor or servovalve cable is disconnected or breaks), the digital controller senses an error and causes the actuator to attempt to correct the error by stroking at maximum force and maximum velocity until it reaches an internal limit or external mechanical obstruction (e.g., tools, specimens, hands). The full force of the actuator will be applied to that limit or obstruction. (A selectable operating range does not reduce the force capability, it only increases the sensitivity of the electronic components.) To avoid a control mode feedback signal loss, protect sensor cables from damage, and never connect or disconnect any cable with electric or hydraulic pressure applied. If the feedback signal is lost, remove hydraulic pressure immediately. An open control loop also results if the cable from the digital controller to the servovalve is disconnected or broken while hydraulic pressure is applied.
- ◆ The composite command signal for the servo control loop may consist of several program inputs. If one of these inputs is suddenly changed while hydraulic pressure is applied, the servo control loop will sense a large instantaneous error and the actuator will respond accordingly. Do not make any program changes unless you know exactly how the change will affect operation.

- ◆ An unexpected actuator stroke or excessive actuator force can result from over programming. The composite command to the servo control loop is the algebraic sum of the Function Generator window's **Mean Level** and **Amplitude** inputs; either can program $\pm 100\%$ of the system's force-producing capability. For example, in most systems, a ± 10 volt signal produces full system response: if the input to the controller is a ± 10 -volt sine wave and **Amplitude** is adjusted to the maximum setting, any mean level offset introduced by the **Amplitude** control causes the command to exceed the capabilities of the system. When determining program commands, make sure to avoid over programming.
 - ◆ Many systems contain hydraulic accumulators that store enough energy to temporarily operate the actuator at full force capacity when the hydraulic pressure is shut off. For this reason, the usual interlock devices will not prevent hazardous actuator stroking.
 - ◆ The failure or shutoff of electrical power to the testing system while hydraulic pressure is applied will cause considerable, unpredictable actuator reaction due to stored energy in the accumulators and irregular pump shutdown. Under these conditions, the actuator will generally stroke at maximum force and maximum velocity in either direction or, if a specimen is attached, apply full tensile or compressive force (i.e., positive or negative acceleration). Ensure that electrical power connections are not interrupted during test system operation.
 - ◆ Do not use any interlock reset to bypass the interlock chain and attempt to start the hydraulic power supply. Doing this will cause the hydraulic power supply to start and hydraulic pressure will be applied regardless of the interlock condition. The error detector may be adjusted to trip whenever a large error is present, preventing the continued application of hydraulic pressure.
-

Guidelines For Installing Specimens

Because you are very close to or in contact with the system force train during specimen installation, this procedure can be the most hazardous part of system operation. Because it is usually necessary to have hydraulic power turned on, follow all of the instructions in this manual in addition to the following:

- ◆ Clear the work area, especially near system crush points.
 - ◆ Ensure that the servo control loop is properly phased and stable (refer to the TestStar Installation Manual for procedures). Be particularly alert for phase or control reversal if the system setup has been modified since the previous operation. If operating the system in force or strain control, adjust the gain control to a value known by experience to be stable for the particular specimen in use.
 - ◆ Use extreme caution when handling or supporting the specimen so that fingers and hands are never exposed to potential crush points during specimen installation. Use tongs to handle the specimen.
 - ◆ To move the crosshead on load units not equipped with hydraulic lifts, support the crosshead using a lifting device capable of supporting the crosshead weight plus the weight of any fixtures and grips. Remove any slack from the crane cable or chain before unlocking the crosshead.
 - ◆ A hazardous situation exists when air becomes trapped inside the lift cylinders on load units equipped with hydraulic lifts. Trapped air can cause erratic movement of the crosshead when the lift controls are operated. After installation, or if the crosshead does not move smoothly, bleed the lift cylinders as directed in the load unit product manual. Stay clear of the lower platen and the crosshead when operating the lift controls.
-

Checking the Hardware Setup

Always determine the necessary hardware configuration required for the test to be performed. Make all necessary changes to the configuration before applying electrical power or hydraulic pressure.

Check for hardware configuration changes

Due to the comprehensive nature of the system's testing capabilities, different types of tests may require changes in the hardware configuration to accommodate specific desired test results. Examples of hardware configuration changes include:

- ◆ Changing from one extensometer to another.
 - ◆ Changing from a high-capacity force sensor to a low-capacity force sensor.
 - ◆ Changing the sensor cartridge for higher or lower resolution testing.
 - ◆ Changing between servovalves on dual servovalve manifolds.
-

When you have multiple force sensors

If the system is configured to use more than one force sensor (e.g., typically, one with a force rating equal to system capability and another with a lower force rating), additional considerations may be necessary to protect the low capacity force sensor from damage. Using a force sensor rated below the maximum capability of the system is basically the same as changing a sensor cartridge. It does not reduce the full force capability of the hydraulic actuator. It only increases the sensitivity of the electronic control and readout components.

Installation and Modification Guidelines

The following installation and modification guidelines recommend design practices and modified system setup considerations that should be observed to minimize system operating hazards. Even when using the system for the first time and setup changes seem unlikely, a thorough understanding of the following guidelines will help in understanding system operation:

- ◆ Tests often operate for extended periods with no supervision and may attract spectators. This combination requires that any test laboratory setup provide adequate protection for bystanders as well as for system operators.
 - ◆ Be sure to study the manuals to gain sufficient knowledge of system operation, and service and modification procedures.
 - ◆ Refer to the TestStar Installation Manual for information about emergency stop connections on the digital controller rear panel.
 - ◆ A competent engineer should be responsible for system installation or modification. The engineer must consider how changes to an existing facility or system might affect safety and reliability.
-

Supervising the System

The engineer responsible for any installation, modification or alteration to a test system should consider the following precautions:

- ◆ Protect all system hoses and cables from sharp or abrasive objects that could cause hose or cable failure. Route hoses and cables away from areas that expose them to possible damage.
 - ◆ To avoid thrashing and subsequent deterioration, hydraulic pressure hoses should be anchored to the ground or tied to a corresponding return line within two feet of the flow outlet end. As an alternative, hoses can be run in trenches or other protected areas. Design enough fittings into a system to allow for the accommodation of dimensional errors without placing severe strains on the fittings or tube ends. Be sure to use appropriately rated fittings from a reputable manufacturer. Pressure line hoses for normal hydraulic service should have a burst pressure at least four times the operating pressure.
 - ◆ Ensure all operators are familiar with any changes to the test system and provide training on how the changes affect operation and maintenance.
-

The Importance of Proper Maintenance

Proper maintenance is important to system operating safety. Without good maintenance practices, system reliability and safety degrades to the point where potential hazards can become extreme dangers. Study the manuals and the following paragraphs before beginning any type of system maintenance.

- ◆ Service must be done only by qualified persons.
- ◆ The service procedures in the individual product manuals are effective ways of maintaining the units. Read the procedures before you start working on a unit, then follow them carefully. In other words, don't get inventive.
- ◆ Use only designated MTS replacement parts. Parts not approved by MTS can adversely affect safety in addition to degrading reliability, increasing maintenance downtime, and voiding warranty coverage.
- ◆ Perform all calibration procedures in the TestStar Installation Manual to avoid improper signal scaling. Electronic signals between system components interact to operate the entire system.
- ◆ Systems that use pneumatic devices (e.g., accumulators, certain tandem and high-rate actuators) contain high-pressure gas that is very hazardous if improperly handled or poorly maintained. Read all gas cylinder labels to properly identify the type of accumulator and the type of gas used.
- ◆ Follow all accumulator charging instructions given in the manuals. When charging accumulators, use only dry nitrogen. (Dry nitrogen can be labeled "oil pumped" or "dry water pumped.") Do not use oxygen in place of nitrogen. If oxygen comes in contact with hydraulic fluid (e.g., if an accumulator bladder ruptures or leaks), a highly explosive condition will exist. When in doubt about any nitrogen charging procedure or about any type of accumulator, consult MTS Systems Corporation (refer to the Preface for information on technical assistance).
- ◆ Protect electrical cables from spilled hydraulic fluid and excessive temperatures that can cause cable hardening and can eventually result in cable failure. Clean spilled hydraulic fluid from cables as soon as possible.

- ◆ Inspect all cables for cuts, exposed wires, or other types of possible damage prior to system operation. Cable connectors must be securely plugged into their respective receptacles. Inspect each cable where it enters the cable connector for signs of excessive flexing (broken insulation) or exposed wires.
 - ◆ Remove all system power before replacing any cable found to be defective. Ensure that all cables have appropriate strain relief devices installed at the cable and near the connector plug. Do not use the connector plug as a strain relief.
 - ◆ Thoroughly inspect hoses for blisters, cuts, or other damage prior to system operation. Any weakening of the wire wrapping or reinforcing should be considered cause for hose replacement. While the system is operating, inspect all hoses and cables to ensure that there is no excessive thrashing, bending, or chafing that could cause cable or hose damage.
 - ◆ Flush the hydraulic system immediately after any of the system's piping (i.e., hoses, hard lines, servovalve, hydraulic power supply components, etc.) has been replaced or its configuration has changed.
 - ◆ Special safety considerations are necessary when operating a system that contains fire-resistant hydraulic fluid. These fluids are usually toxic and can present a lethal situation if fluid is accidentally swallowed or if a sufficient amount of fluid is absorbed through the skin. Avoid breathing the vapor or mist from these fluids, do not eat or smoke while working with these fluids, and practice absolute personal cleanliness when working with these fluids. Do not mix fire-resistant fluids with petroleum-based fluids. Also, do not add fire-resistant fluids to systems incompatible with these types of fluids (doing so will destroy seals and severely damage the equipment).
-

Hazard Conventions Used in This Manual

The following techniques are used to highlight special types of information.

WARNING

Warnings alert you that something hazardous can occur if you do not follow the instructions carefully. Physical injury to you or to the machine (or both) will likely be severe.

The plain (unbolded) text below the initial bolded sentence gives you additional instructions about how to avoid the hazard.

CAUTION

Cautions alert you that something hazardous can occur if you do not follow the instructions carefully. However, the personal injury or equipment damage will likely be moderate.

Cautions are also used for procedures that can cause loss or corruption of computer programs or data.

NOTE

Notes are used to point out especially important information that you should know before performing an operation, but failure to do so is not likely to result in a hazard.

Boldface text

Boldface terms such as **Emergency Stop** are direct references to physical controls and indicator labels on the test system.

How to Obtain Technical Assistance

If you have any questions about an MTS system or product, contact the MTS corporate service center.

Note Review the following pages for information about what to expect when you contact us.

Address

MTS Systems Corporation
Service Support Group
Technical Support Department
14000 Technology Drive
Eden Prairie, Minnesota 55344-2290

Telephone

In the United States (all 50 states) HELPLine (800) 328-2255

Outside U.S.

Contact your local service center

Telex

29-0521

Fax

Technical support questions (612) 937-4766

General questions

(612) 937-4515

Internet

E-mail

Info@mts.com

Internet Home Page

<http://www.mts.com>

What to Expect When You Call

Your call will be registered by a HELPLine agent. The agent will ask for your site number. If you do not have an MTS site number or do not know your site number, you should contact your MTS sales engineer.

The HELPLine agent may also ask to verify the following information:

- ◆ Your company's name
- ◆ Your company's address
- ◆ Your name and the telephone number where you can normally be reached.

If you have called before regarding this problem, we can recall your file. You'll need to tell us the following:

- ◆ The MTS work order number.
 - ◆ The name of the person who helped you.
 - ◆ Be prepared to respond to questions when interfacing with MTS technical support personnel. We may ask you to perform certain tasks so we can locate the source of the problem.
-

Before you call

Prepare the following information before you call HELPLine support to prepare for the troubleshooting process.

Know your site number and system number.

Describe the problem you are experiencing:

- ◆ How long has the problem been occurring?
- ◆ Can you reproduce the problem?
- ◆ Were any hardware changes made to the application or system operating software before the problem started?

Have the following information available:

- ◆ If relevant, print-outs of configuration files, and test procedures.
- ◆ The type or model number of your test frame, load unit, etc.

- ◆ The type of model number of your controller
- ◆ Model number and size of your hydraulic service manifold
- ◆ Serial number of any suspect component

If you are experiencing a computer problem, please have the following information available:

- ◆ Manufacturer's name
- ◆ Manufacturer's model number
- ◆ Type of system memory
- ◆ Amount of system memory
- ◆ Floppy drive information (model number, size, and capacity)
- ◆ Hard drive information (model number, size, and capacity)
- ◆ Manufacturer of printer/plotter and model number
- ◆ Mouse information (bus, serial; connected to what port?)
- ◆ Graphics board information (manufacturer and model)
- ◆ What other boards are installed in the computer?
- ◆ Is the system part of a network?

If you are experiencing a software problem, please have the following information available:

- ◆ Operating software information
 - What type of operational software are you running?
 - What version level of operating system is running?
 - What window type is used?
- ◆ Application software information:
 - What applications are you running? (MultiPurpose TestWare, etc.)
 - Know the version of each software application involved.

Other software being used:

- ◆ What other software was running when the problem was encountered? This could include such things as screen savers, keyboard enhancers, and print spoolers.
 - ◆ Know the name and version of each software program involved.
-

While on the phone**Prepare yourself for troubleshooting while on the phone:**

- ◆ Try to call from a telephone close to the system so that you can conduct some active testing over the phone.
- ◆ Have the original operating and application software disks available.
- ◆ If you are not familiar with all aspects of the operation of the equipment, have the necessary people available to assist you.

Prepare yourself in case a call back is required:

- ◆ Remember to ask for the work order number.
 - ◆ Record the name of the person who helped you.
 - ◆ Make sure you are able to write down any specific instructions to be followed, such as data recording or performance monitoring.
-



*TestStar II*TM

Control System

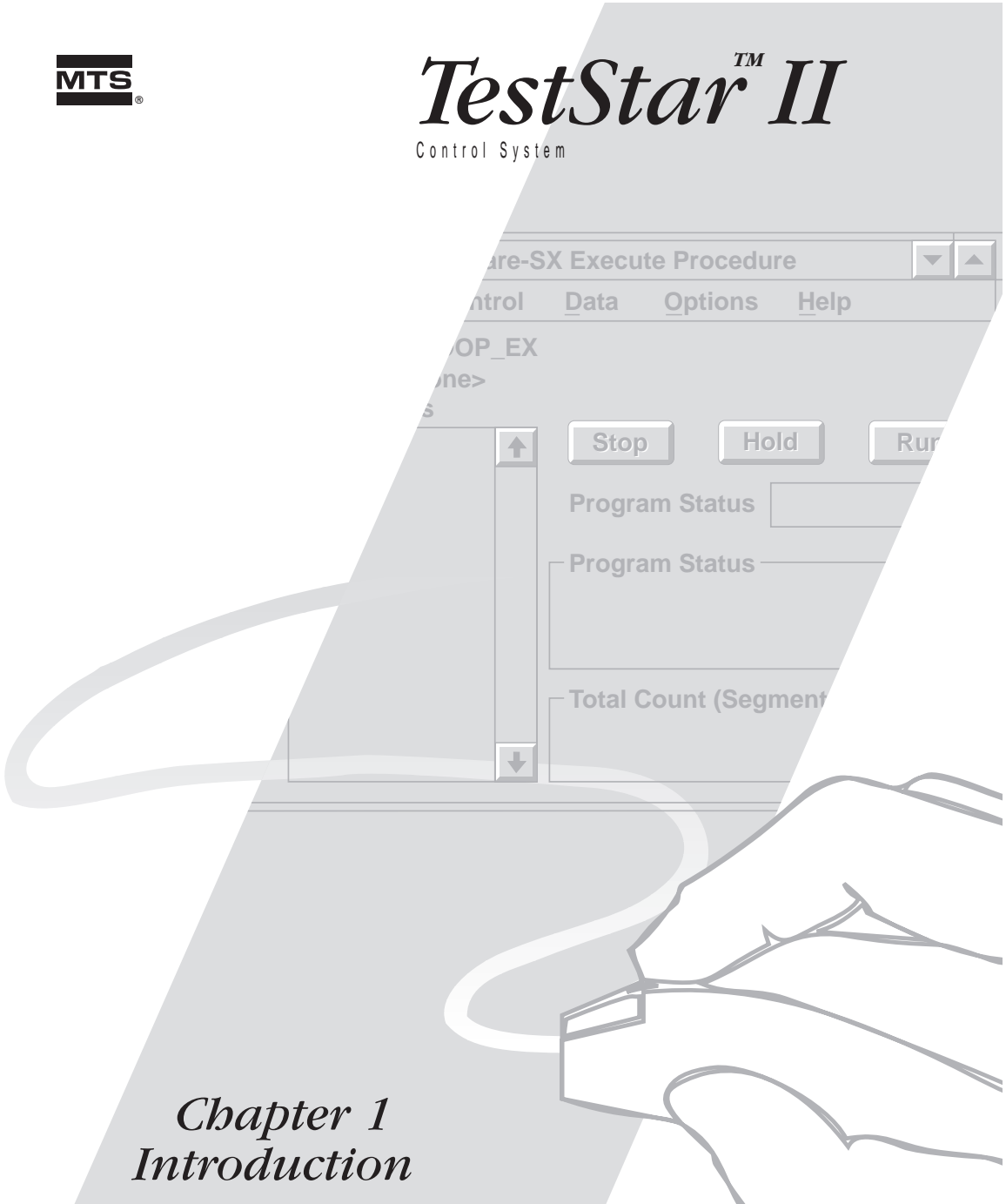

Chapter 1 Introduction

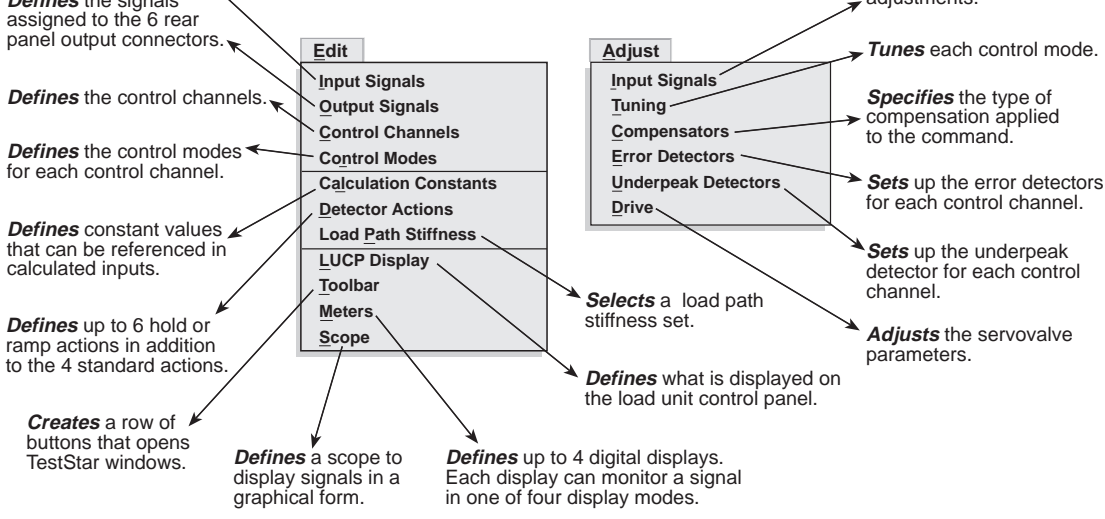
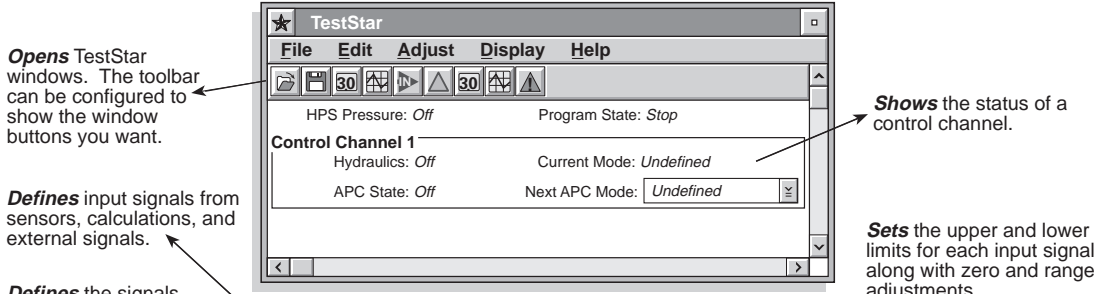
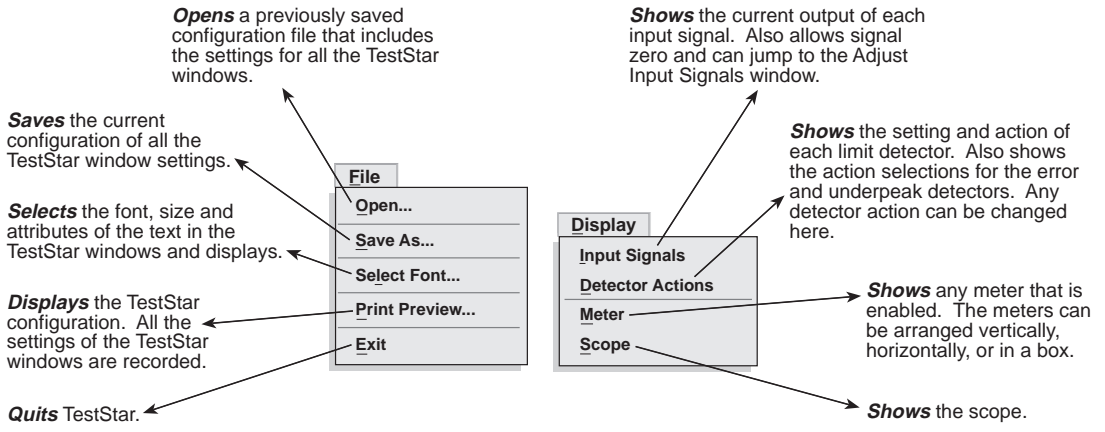

Chapter 1

Introduction

WARNING

Read the Safety Precautions in the Preface of this manual before you use the equipment.

The Safety Precautions portion describes hazards that apply to test systems and offers suggestions for avoiding hazards.

MTS test systems are powered by high-pressure hydraulic fluid. High-pressure hydraulic fluid is potentially dangerous. It is very important that you remain aware of hazards that apply to a test system.

Contents

How to Use This Manual	34
Window Controls	37
Abbreviations	45
Introducing the TestStar Software	46
Starting TestStar	48
Main TestStar Window	49
Using TestStar Configuration Files	50
Using the Fault Status Window	52
Clearing a Detector	54
Clearing an Interlock	56
Using On-line Help	59
Using the Load Unit Control Panel	61
Main Module Controls and Indicators	62
Control Channel Modules	66

How to Use This Manual

If you intend to read this manual from beginning to end, you will discover that it is really a sleeping aid. But, if you want to find a specific piece of information, you will find that it is more than adequate.

As you have probably noticed, the chapters are arranged by the TestStar menus and the support programs. Each chapter is organized according to a menu selection. Many of the TestStar windows change according to your selections, each window variation is documented.

For example, when you select a Mode Definition Type in the Edit Control Channels window, new controls are added to the bottom of the window. The controls to define the different types of control modes (the Mode Type selections) differ from each other.

Types of information

The information in this manual can include any combination of the types of information shown below.

Don't forget the index!

Random Topics

How It Works

Works

More Information

Detector Actions

A detector action is an event that occurs when conditions of a detector are true. This is also called a detector fault.

- Four standard actions are always available.
- You can define up to six hold or ramp/hold actions.
- The detector actions are available for all TestStar detectors.

Defining actions

You need to know the following before you define an action.

- How do you want the actuator to be controlled when a detector action occurs?
 - What control mode is the best to prevent specimen damage or control actuator movement when a detector action occurs?

For example: if the specimen breaks and force control is used, the actuator continues to move until the required force is detected. But a length control mode can still ramp or hold the actuator when the specimen is broken.

How it works

The following are the four standard actions available for every detector.

- Disabled**—turns the detector off.
- Indicate**—displays a message in the Fault Status window that the detector has been triggered.
- Hydraulics Off**—turns off the hydraulic pressure and displays a message in the Fault Status window.

More information

Cabling *Installation Manual (3)*
Setting limits to input signals *Adjust Menu (4)*

Toolbar Button

Title

Prerequisites

Sample Window

Basic Explanation

Detailed Explanation

Using the Window

Edit Detector Actions Window

Prerequisite

Custom-defined actions stop the test program. You can continue the test by pressing the Run button. You must define the input signals before defining the control modes for a control channel.

Use this window to define up to 6 detector actions.

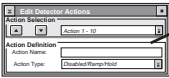

Window controls

Control	Function
Action Selection	Selects an action to define. Actions 1 - 4 are predefined and cannot be changed.
Action Name	Names the detector action. The name you enter is used throughout TestStar to identify this action.
Action type	Specifies a ramp or a hold action. Controls needed for the selection are added at the bottom of the window.

Standard actions

The first four actions cannot be changed and are identified. TestStar software installation. Each control channel has a valve driver module. test by pressing the Run switch (LUCP) or the select run.

Using the window

- Select a dot location or calculated input in the Signal Selection area. This selection determines the Signal Type selection.
- Enter a Signal Name if you want; otherwise, the text will be used.
- Select a Signal Type. Most of the time a single selection is available.

Don't forget the index

When in doubt use the index. It contains entries for both this Reference manual and the Installation manual. Index listings for the Installation manual are preceded with the letters IN and RE for this manual.

Toolbar button

Any menu or window that can be directly accessed from the toolbar has its associated button displayed with the menu or window title. All TestStar windows can be accessed from a menu or the toolbar. See the Configure Toolbar window for more information.

Titles

Each description is titled with the name of a menu selection or a name of a window. Menu titles are also shown next to the page number at the bottom of the page. Following the title is a brief paragraph explaining what the menu (or window) is used for.

Prerequisites

Sometimes a window requires another function (or functions) to be completed before you can use the window. This section lists those requirements.

Sample window

Each window is illustrated in its generic form (that is, usually no values are shown). This serves as a guide when you are using this manual without an operational work station in front of you. Words shown in italics are generic names describing a selection.

Basic explanation

This category of information gives a concise explanation of the various controls available in the window. The descriptions are intentionally kept brief to serve as memory joggers (for experienced users) or as a quick introduction (for the novice). Most of these descriptions have a table that describes each parameter and selection.

Detailed explanations

Some items in the Basic Explanation table require additional explanation. These paragraphs provide extended descriptions to provide the necessary details.

Using the window

Many of the TestStar windows can be completed intuitively – that is, there is a logical progression (such as from the top to the bottom). However, some windows require that you work through them in a specific order or that certain selections require additional considerations.

More information

More information consists of a list of related topics that include an italicized title of the window, menu, or topic where related information is located along with the chapter number in parentheses.

A related topic...

...can be found in chapter (1)

How it works

Sometimes it is helpful to describe how a feature works to understand what it does. This kind of information helps you sound more intelligent when someone asks you what you are doing.

Random topics

Random topics are usually found at the beginning of a main topic (such as an overview of a menu selection) or the beginning of a chapter. This kind of topic may pose questions or offer suggestion so you can determine why you want to use a feature. These topics can also provide information to help you choose from the available selections. Information that is common for all selections may also be described.

Window Controls

This sample window shows the types of controls you will see in the TestStar windows. The following describes the controls shown.

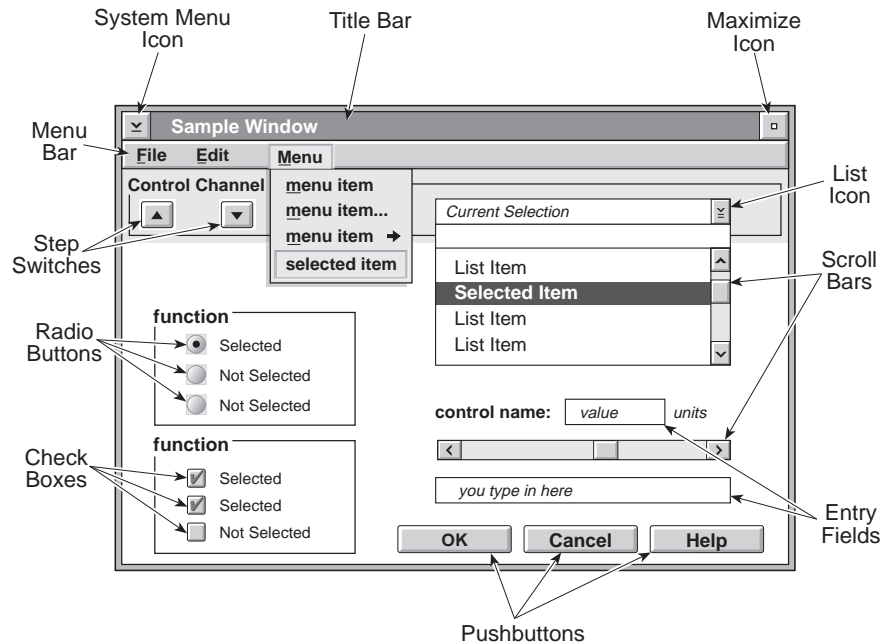

Using a mouse

The left and right mouse buttons can have different functions. In TestStar, unless otherwise noted, all mouse activity (selecting, single and double-clicking) uses the left mouse button. Most functions are easier to use with the mouse.

Using the keyboard

The keyboard can emulate the mouse functions. The keyboard can be useful for menu and list selections.

- | | |
|----------------------|---------------------------------------|
| ◆ Alt + Esc | move between windows |
| ◆ Tab | step between window controls |
| ◆ up and down arrows | step up and down a list of selections |
| ◆ Enter | make a selection |
| ◆ Alt + letter | display menu |
| ◆ letter | menu selection or list selection |

Title bar

The title bar shows the name of the window. The title bar may include a small version of the program icon for the System Menu Icon.

The System Menu Icon is primarily used to move, size, or close the window. A single click (from either mouse button) displays a menu of window functions or press the Alt key.

- ◆ Double-click this icon or type Alt and F4 to close the window.
 - ◆ The Minimize Icon changes the window into an icon located in the at the bottom of the screen (or the OS/2 Minimized Window Viewer).
 - ◆ To reopen the window, double-click the minimized icon or:
 - For OS/2, press both mouse buttons to display the Window list and double-click the name of the window.
 - For Windows NT, double-click the desktop to display the Task List and double-click the name of the window.
 - ◆ The Maximize Icon changes the window to fill the entire screen. Press the Maximize Icon again to return the window to its scaled size.
-

Moving around a window

Windows have several controls in them and each one can be used when it is selected or “has focus.” A control that has focus is identified by highlighting it – reverse video for text, an outline around a graphic, a different color, or the appearance of a button being pushed. When an object is selected, it looks different.

For example, selecting a menu in the menu bar makes the name of the menu look like a button being pressed, and the list of menu items is shown.

Using a mouse

Move the mouse until the on-screen pointer is over a control. Press the left mouse button to select the control. You can now use the selected control.

Using the keyboard

Use the Tab key to move between controls. Each time you press the Tab key, the selected control moves to the next control. The sequence of controls assume a starting point in the upper left corner and progresses from left to right and top to bottom. Use the Tab and shift keys to move the selection moves between control groups.

Menu bar

Selecting a menu with the mouse highlights the menu name and displays the menu items. Selecting a menu item highlights the item name.

Three types of menu items are used:

- ◆ Menu items with an ellipsis mark (...) indicates that the menu selection displays another window.
- ◆ Menu items with an arrow indicate the menu selection displays another menu.
- ◆ All other menu items perform an action and may display a dialog box.

Some menu or window items may be dimmed (“grayed out”). This indicates either of the following:

- ◆ The item is not available in the application.
- ◆ A prerequisite action has not been performed yet.

Using a mouse... Select the menu name and drag the mouse to highlight a selection.

Using the keyboard... Menus and menu items identify their keyboard access with an underlined letter. Press the Alt and the underlined letter keys to display the menu, then press only the underlined letter of a menu item to activate the selection. The up or down arrow keys can also select a menu item when a menu is displayed. Press enter to activate the selection.

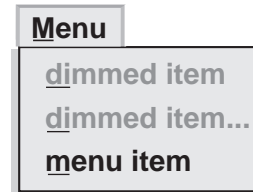
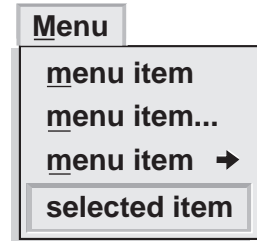

Radio button

A radio button is a small oval next to a selection. A function name accompanies the group of selections you can enable.

You can enable only one of the choices. A filled-in oval indicates the enabled selection.

Using the mouse... Enable a selection by clicking the selection name or the associated radio button; disable the selection by clicking a different selection name or its associated radio button.

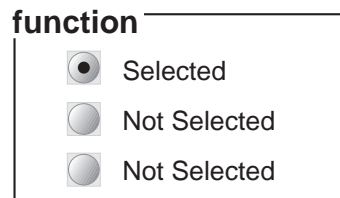

Using the keyboard... Use the Tab key to highlight a selection. Use the space bar to enable the selection. Disable the selection by enabling a different selection.

Check box

A check box is a small box next to an item that can be selected. A function name accompanies the selections you can enable.

You can enable one or more of the selections. A selection is enabled when the check box has an “√”, or “X” in it.

Using the mouse... Enable a selection by clicking the selection name or its associated check box – an appears in the check box. Disable the selection by clicking the selection name or its associated check box and the X disappears from the check box.

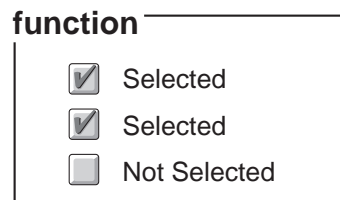

Using the keyboard... Use the Tab key to highlight a selection. Press the space bar to enable the selection. Press the space bar again to disable the selection.

Scroll bar

TestStar uses two types of scroll bars: horizontal scroll bars and vertical scroll bars. Each scroll bar includes a slider box and arrow icons to control scrolling.

Vertical

- ◆ The slider box and arrow icons are grayed out if all information is shown.
- ◆ A vertical scroll bar indicates that a selection field contains more information than can be shown at one time.
- ◆ Use a vertical scroll bar to scroll up and down through a list of selections or text.
- ◆ The slider box controls the portion of information that is shown. The arrow icons step the portion of information up or down one selection.

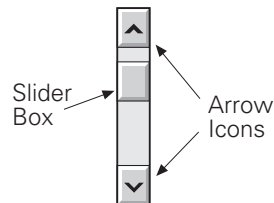

Horizontal

- ◆ Horizontal scroll bars include an entry field above the scroll bar to show a value.



- ◆ Use a horizontal scroll bar like an adjustment to increase or decrease a value.
- ◆ If the name of a horizontal scroll bar is in a pushbutton, the adjustment range of the horizontal scroll bar can be changed

Using a mouse... Drag the slider box until the desired selection or value is displayed. Use the arrow icons to step through the selections or increment the value. For vertical scroll bars, click above or below the slider box to page up or down through the selections.

Using the keyboard... For vertical scroll bars, use the Home and End keys to jump to the top or bottom of the list. Use the Page Up and Page down keys to page through the selections. Use the up and down arrow keys to step through the list one item at a time

Button

A button performs an action or displays a window. The most common buttons are the following:



Pressing an OK pushbutton accepts any changes you have made in a window. Pressing OK in a dialog box acknowledges the statement of the dialog box.



Pressing a Cancel pushbutton returns you to the previous screen without accepting any changes you may have made.



Pressing a Help pushbutton displays a text window that describes the controls and functions of the window containing the Help pushbutton.

Using the mouse... Select the button by clicking on it.

Using the keyboard... Press the letter that corresponds with the underlined letter of the button or use the Tab key to select the pushbutton, then press the Enter key.

Entry field

An entry field is a box where you can type information. To change an existing entry, highlight the entry and press delete or type a new value.

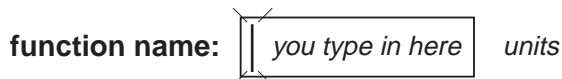

A cursor blinks in an active entry field.

Using the mouse... Select the entry field by clicking on it, then type the entry. Use the OK pushbutton to accept the information you have entered.

Using the keyboard... Use the Tab key to select the entry field, type a value or name into the field, then press the Enter key.

List button

A list button displays a list of selections. The current selection is shown in the box with the list icon. The box may include a scroll bar.

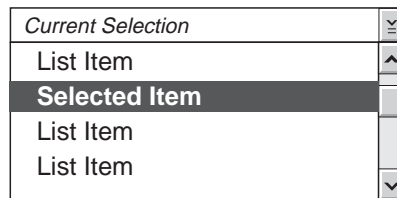

- ◆ Selecting one of the list items makes that selection active.
- ◆ A scroll bar that is “grayed out” indicates that all the possible selections are being displayed.

Using the mouse... Press the list button and highlight your selection. Use the right mouse button to close the list without making a selection.

Using the keyboard.... Use the up or down arrow keys to step through the selection list. You can also type the first letter or two of a selection from the list and it will be selected.

Step switches

The step switches work in conjunction with a list icon. Press the list icon to see the list of selections. The step switches let you step up and down through the selection list.

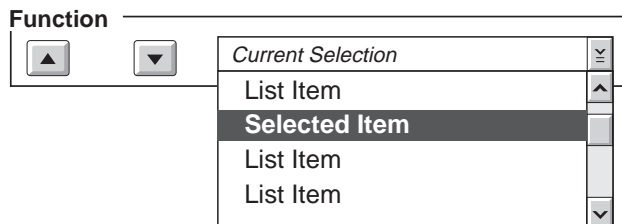

Using the mouse... Press the up or down step switch until the your selection is displayed. Or press the list icon and highlight your selection.

Using the keyboard.... Use the Tab key to select the up or down step switch. Press Enter to step operate the button. You can also type the first letter or two of a selection from the list and it will be selected.

Dialog box

A dialog box is a screen display that requests information from you or requires you to acknowledge information. Typically, it is similar to the box shown below. **Make sure** to read the statement in the box *carefully* before pressing OK – you may be confirming an operation that has an effect opposite to the one you actually want.

TestStar is located in the MTS-TSII folder on the Desktop.

Optional applications like TestWare-SX are also placed in the MTS-TSII folder.

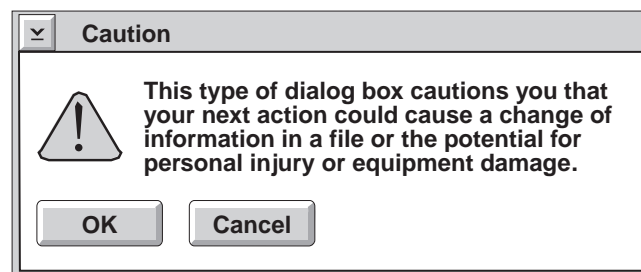
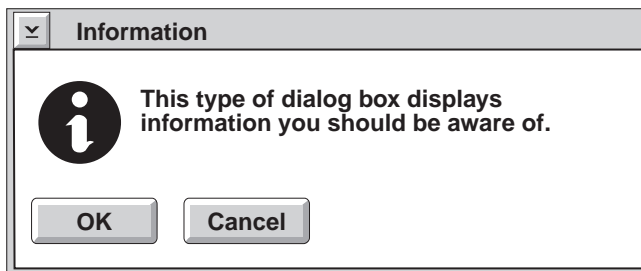
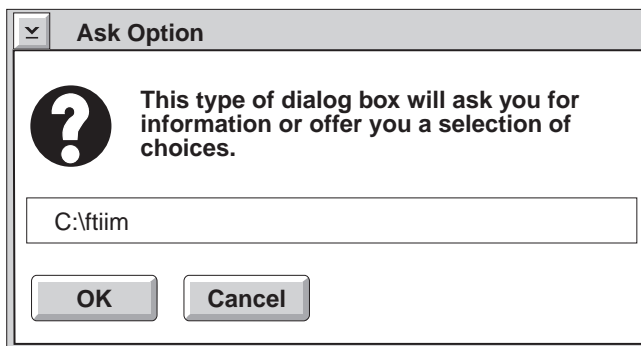

Using the mouse... Press the pushbutton representing your choice.

Using the keyboard.... Type the underlined letter of the pushbutton you want to choose. Use the Esc key to select Cancel.

Abbreviations

Because of screen space limitations, some of the TestStar prompts or labels have names other than the official names of functions or equipment. These shorthand terms are:

SHORTHAND TERM	ACTUAL NAME
APC	Actuator Positioning Control
CLC	Channel Limited Channel (Pod control mode)
CASC	Cascade Control Mode
Cmd	Command
Ctrl	Control key
ESC	Escape key
HPS	Hydraulic Power Supply
HSM	Hydraulic Service Manifold or actuator manifold
PIDF	P – Proportional Gain Control I – Integral Gain Control D – Derivative Gain Control F – Feed Forward Gain Control
Pod or LUC	The Load Unit Control panel mounted to the load unit.
Stroke or Length	Displacement

Introducing the TestStar Software

TestStar software requires the Windows NT (version 3.51 or newer) or OS/2 (version 3.0 or newer) operating system. You should have some knowledge of the operating system to successfully use TestStar.

The OS/2 desk top is shown here.

The Windows NT desk top shows all the icons in a single Program Group.

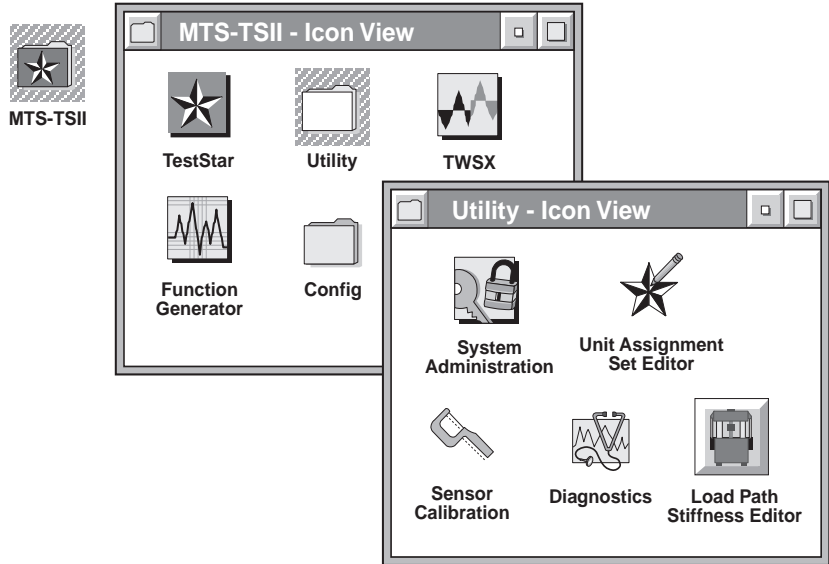

TestStar programs

The TestStar software consists of a number of programs.



TestStar



Function Generator

The TestStar application is the main program that sets up a test and controls the digital controller. Double-clicking this icon starts TestStar by opening the Login window where you must enter a user name and password.

The Function Generator program creates and runs a test command. It can produce simple monotonic or cyclic test commands using triangle, sine, and square waveshapes. See Chapter 6, *Function Generator* on page 205.

**TWSX**

TestWare-SX (TWSX) is an optional, flexible, general-purpose program that combine processes that can produce a test command, acquire data, and can interface with external devices. This application has its own manual.

OS/2 only

**Config**

This folder contains all the TestStar configuration files that you create. Double-clicking a configuration file icon starts TestStar by opening the Login window where you must enter a user name and password. Each test you run should have a TestStar configuration file.

**Administrator**

The Administrator program defines user names, passwords, and their access to the other TestStar applications. See Chapter 7, [System Administration](#) on page 231.

**Unit Assignment Set Editor**

The Unit Assignment Set Editor allows you to define a set of preferred units for the various values used in TestStar. Each dimension can have a preferred set of units assigned. *For example*, you may prefer millimeters or inches for length dimensions. See Chapter 8, [Unit Assignment Set Editor](#) on page 245.

**Sensor Calibration**

The Sensor Calibration program creates or imports sensor calibration data. This program keeps a data base of you calibrated sensors. You can install calibration data for sensors calibrated at MTS Systems. See Chapters 6 - 9 in the Installation manual.

**Diagnostics**

The Diagnostics program checks each hardware circuit card in the digital controller. See Appendix D in the Installation manual.

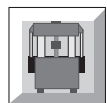
**Load Path Stiffness Editor**

The Load Path Stiffness Editor creates sets of values that compensate for deflection in the load path. This is used with the Model 790.31 Dynamic Characterization process and the Model 790.33 Static Deflections process. See Appendix F, [Load Path Stiffness Editor](#) on page 317.

Starting TestStar

When you double-click the TestStar icon, the Login window appears. If your user name and password are valid, the main TestStar window opens.

- ◆ On new systems, both the User Name and Password are “MTS.”
- ◆ See Chapter 7, *Creating a New User* on page 240, to create user names and assign passwords with the System Administration program.

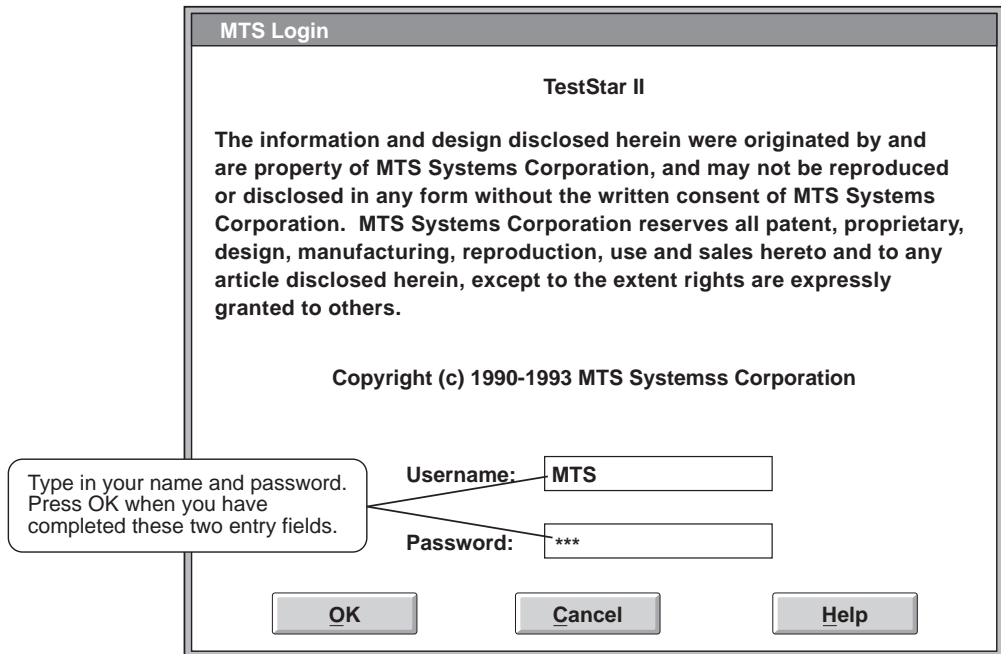

- ◆ The password is not displayed; instead, asterisks are used for password security.
- ◆ The User Name opens a TestStar configuration file. This file can have all TestStar controls and settings set up for a specific kind of test. See “Using TestStar Configuration Files” in this chapter.
- ◆ See Appendix E, *Bypassing the Login* on page 315, for a way to bypass the login procedure.

Main TestStar Window

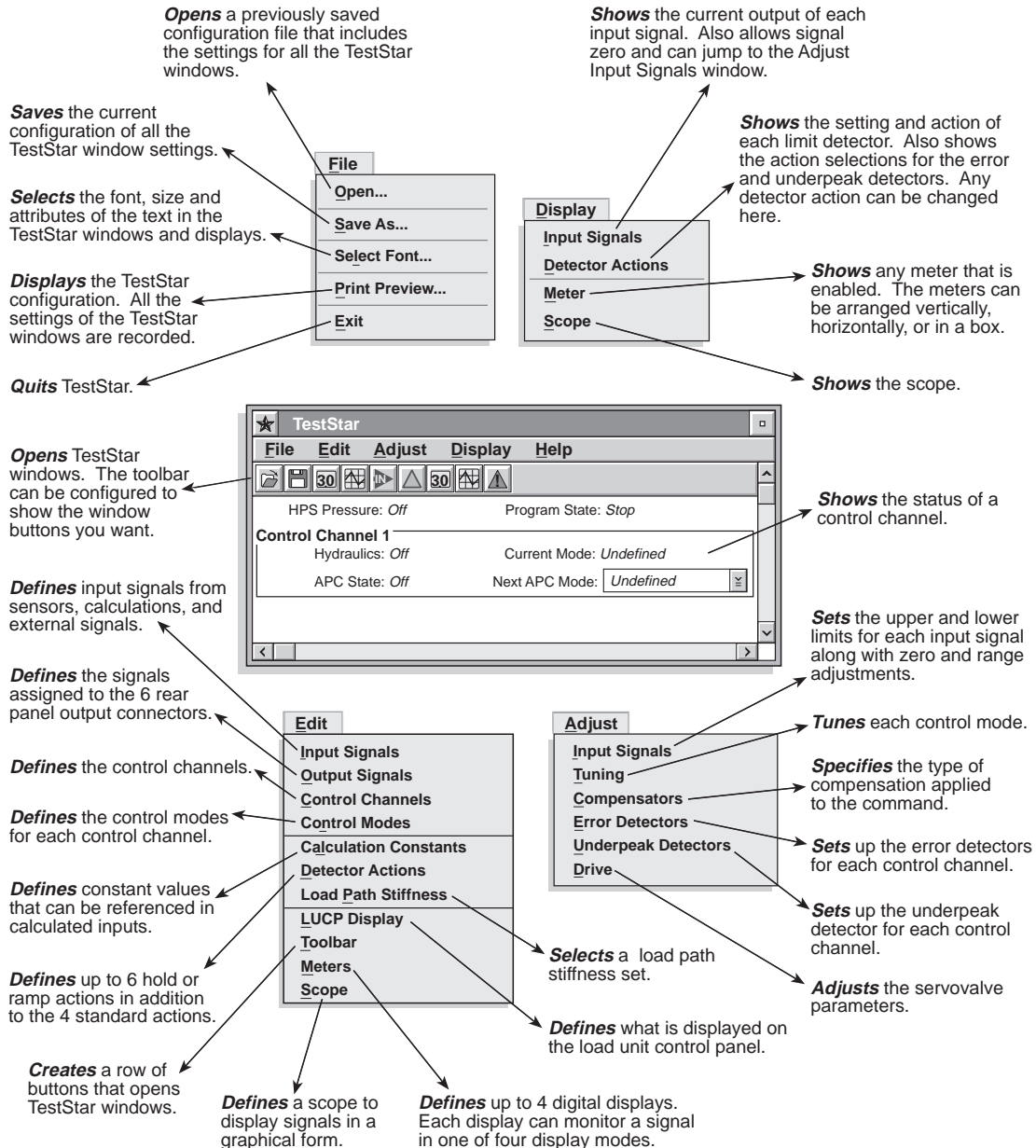

Using TestStar Configuration Files

Predefined settings allow you to completely set up the TestStar controls for a specific test and save those settings as a configuration file.

A TestStar configuration file contains information about every selection you made in every TestStar window. Each type of test you use should have a different configuration file. The configuration file not only saves every TestStar parameter setting, it also includes the size and screen location of every TestStar window.

The configuration file is one the most useful tools in TestStar. It allows you to completely set up TestStar for a specific test, then save all the settings you made. You can later recall those settings when you need to run the same test or a similar test.

Configuration file

The configuration file is saved with a **.TCC** extension that represents TestStar controller configuration. Throughout this manual a TestStar controller configuration file is simply called a configuration file.

The configuration file contains the settings for all the window parameters entered with the Edit, Adjust, and Display menus (even the window positions are recorded).

The configuration file allows you to open TestStar with a set of predefined test parameters. A configuration file is loaded when you log into TestStar; this ensures that the servo loop has known parameters assigned.

You can also open and change the configuration file after you've logged into TestStar. This allows you to recall a file with predefined parameter settings so you don't have to enter them again.

The advantage of configuration files

Although the flexibility of TestStar permits setting up a wide variety of tests, many users need to perform repetitive testing of similar specimens, or else have tests performed by persons relatively inexperienced in materials testing. In either event, these files permit you to store almost all of a specific test's parameters for recall later. In addition, having a configuration file open when you start TestStar ensures that the servo control loop has known parameters assigned.

Define a file for each type of test

Each type of test you use should have its own configuration file. This allows you to recall previous parameter settings so that you don't have to enter them again.

- ◆ Although one normally associates user name with people's names, consider making "user names" the same as test names if your workstation runs different tests. This allows TestStar to automatically match the correct configuration file with a specific test.
-

Each user name has a default configuration file

A system administrator can assign a default configuration file for each user name. This file, along with a unit assignment set, are automatically loaded when you log onto the system. (See the Installation Manual for the procedure.) You can always change the configuration file after you logged into TestStar.

- ◆ If your system has both experienced operators and trainees, consider setting up separate files for the trainees. Doing so can neutralize the possibility of their corrupting existing carefully adjusted files.
-

Using the Fault Status Window

The Fault Status window appears whenever a detector action or a hardware interlock becomes active.

See Clearing a Detector or Clearing an Interlock for procedures to remove the fault from the Fault Status window.



Use this window to identify active detector actions and interlocks.

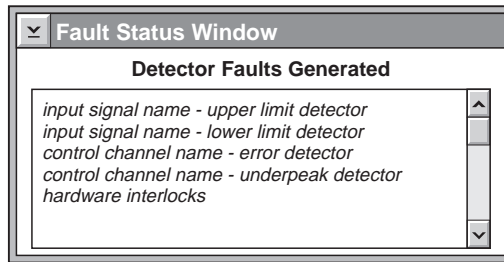

The source of a detector action is identified by the name of the input signal or control channel along with the type of detector. Interlocks are identified with the type of interlock.

More than one detector action or interlock may occur. Sometimes the first detector fault causes other faults to occur.

If an interlock is active, one of these load unit control panel indicators is lit.

- Interlocks**
- Emergency Stop
 - Controller
 - Hydraulic
 - Mechanical
 - Auxiliary

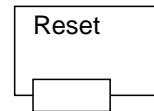

You must use the Reset switch on the load unit control panel to clear an interlock or detector fault. If a fault is detected after being reset, it is displayed again.

Detector actions

Detectors monitor specific test conditions. The purpose for detectors is to perform an action when a detector condition is satisfied. The following are the actions you can use:

- ◆ **Disabled** – turns the detector off.
- ◆ **Indicate** – displays a message in the Fault Status window that the detector has been triggered.
- ◆ **Hydraulics Off** – turns off the hydraulic pressure at the service manifold, displays a message in the Fault Status window and lights the Aux indicator on the LUCP.
- ◆ **Interlock** – turns off the hydraulic pressure, generates an interlock signal, clamps the servovalve, lights the Controller (LUC) indicator, and displays a message in the Fault Status window.
- ◆ **Customer-defined** – these actions can be defined to ramp or hold the control channel output. These actions may also be identified with a customer-defined name or as Action 5 - 10.

Note *Customer-defined actions are created with the Edit Detector Actions window.*

Interlocks

An interlock monitors a specific condition. The purpose of an interlock is to prevent hydraulic pressure from being applied or starting a test before certain conditions are satisfied. Once a test begins, an interlock can stop the test and remove hydraulic pressure if a specific condition occurs.

An active interlock turns off the hydraulic pressure, generates an interlock signal, clamps the servovalve, and displays a message in the Fault Status window.

- ◆ Some tests are designed to cause the specimen to fail. An interlock is used to stop the test and protect the equipment.
 - ◆ One of your initial detector settings may be inadequate for the test. The interlock may stop the test and you can readjust it and continue the test.
 - ◆ You observe a problem and press an Emergency Stop switch.
 - ◆ A component fails and causes an interlock.
-

Clearing a Detector

Determine the cause of the fault

All detector faults must be cleared with the Reset switch on the load unit control panel.

For example, assume an excessive limit is detected. The selected action holds the output so the detector can't automatically clear itself. If pressing Reset doesn't clear the fault, there are two ways to clear this detector.

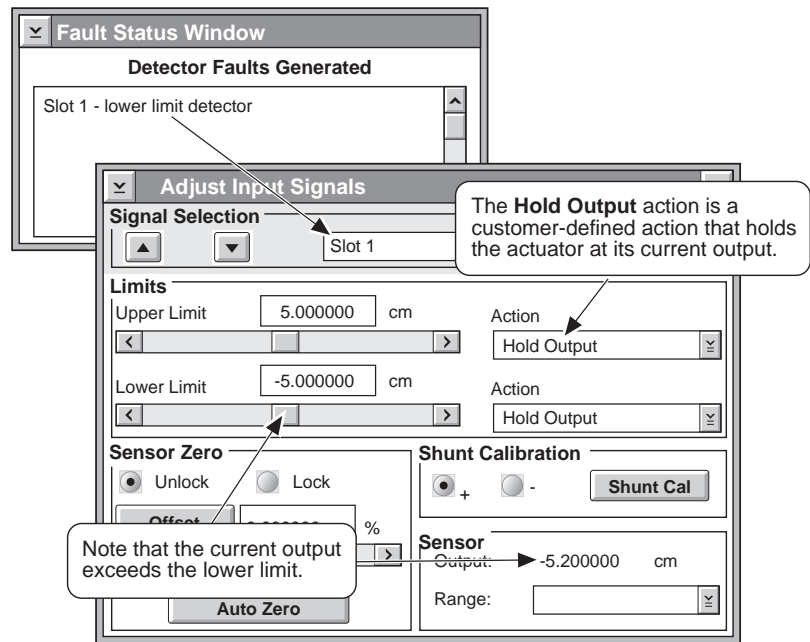

One – select an APC mode in the main TestStar window and use the Actuator Positioning Control on the load unit control panel to adjust the current output within the upper and lower limits. Then press the Reset switch.

Two – open the Adjust Input Signals window and change the lower limit value. Then press the Reset switch to clear the fault.

Upper and lower limits

The sensor feedback became less than the lower limit setting or more than the upper limit setting.

- ◆ the characteristics of the specimen are changing
 - ◆ the specimen is broken
 - ◆ the limit values are incorrect for the test.
-

Underpeak

The sensor selected for the underpeak detector failed to reach the minimum or maximum setting. The characteristics of the specimen are changing or the underpeak values are incorrect for the test

- ◆ the characteristics of the specimen are changing
 - ◆ the underpeak values are incorrect for the test.
-

Error detectors

The difference between the test command and sensor feedback signals exceeded the error 1 or error 2 setting.

- ◆ the characteristics of the specimen are changing
 - ◆ the specimen is broken
 - ◆ the error values are incorrect for the test.
-

Clearing an Interlock

- Procedure**
1. Determine the type of interlock 56
 2. Determine the cause of the interlock 57
 3. Correct the cause of the interlock 58
 4. Clear the interlock 58

Step 1 Determine the type of interlock

When an interlock occurs, the Fault Detector window becomes active.

The first cause of an interlock is shown in the Fault Detectors window.

Sometimes one interlock causes other interlocks to occur.

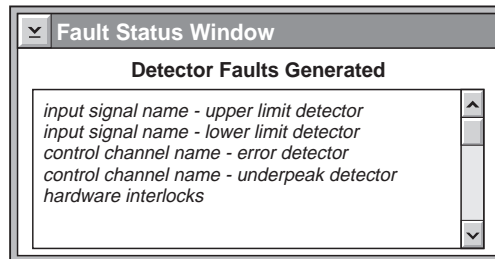

Check the load unit control panel Interlock indicators. One or more of these indicators may be lit.

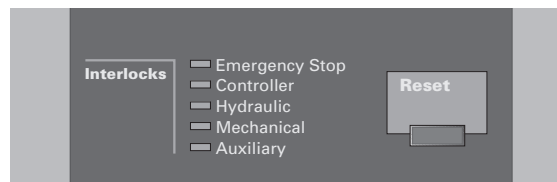

Step 2 Determine the cause of the interlock

Review the following to determine how each interlock occurs.

FAULTS AND INTERLOCKS	EXPLANATION
AD Overrun	The analog-to-digital converters are overwhelmed by a high level of conversion activity. Review your test strategy.
Auxiliary Interlock	An auxiliary interlock does not remove hydraulic pressure; instead, it inhibits a test from starting. This is usually caused when the crosshead is unlocked or by an external device connected to the rear panel connector J43. The Hydraulics Off detector action also can light this indicator. Lock the crosshead or correct the cause of the detector action.
Controller Interlock	This is caused by a plug-in module or a software detector (limits, error, or underpeak). Check the Fault indicators on all plug-in modules. Check the Error indicators of the machine control modules. A lit indicator indicates the module be replaced. The Power indicator should be lit.
DRP Overrun	The data reduction process is overwhelmed when collecting too much data too quickly. Review the characteristics of any data acquisition process.
Emergency Stop	Any one of the Emergency Stop switches has been pressed. Twist the switch clockwise to release it.
Feedback Conditioner	This is caused by a loss of excitation to or from a sensor. Review the conditioner modules for a lit Fault indicator. Check if the sensor cable is connected. Otherwise replace the cable or conditioner module.
Hydraulic Interlock or Servo Interlock	This interlock is caused by the hydraulic power supply or servomotor. Check for one of the following: <ul style="list-style-type: none"> ◆ low hydraulic fluid ◆ high hydraulic fluid temperature ◆ dirty hydraulic filter ◆ motor thermal overload
Mechanical Interlock	This is caused by an external device connected to the rear panel connector J23A or J23B.
Next Control Mode	This is caused by a conditioner reaching its maximum (saturated) or minimum output. Review the conditioner modules for a lit Fault indicator. This usually happens before hydraulic pressure is applied.

Step 3 Correct the cause of the interlock

After you have determined the cause of the interlock you need to correct it. Your course of action is dictated by the type of interlock, the type of test you are running, and how your test system is configured.

It is beyond the scope of this manual to provide procedures to correct all possible interlocks. You will need to produce your own interlock methods and procedures for your equipment and test requirements.

Step 4 Clear the interlock

After you have corrected the first interlock, press the **Reset** switch to clear it. Sometimes the first interlock can cause other interlocks to occur.

Any interlock that has not been corrected will occur again, lighting the appropriate indicator and displaying the interlock in the Fault Status window.

Note *If the interlock was caused by a power failure and you are using TestWare-SX, you can recover the test (see the TestWare-SX Application Manual).*

Press the **Reset** switch on the load unit control panel.

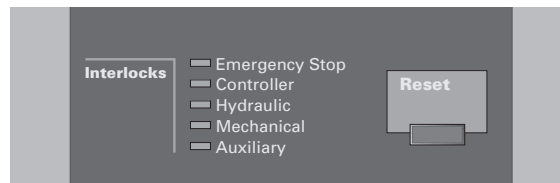

Using On-line Help

From any window, one or more of the following access the help utility:

- ◆ Press the F1 function key.
- ◆ Select Extended Help (OS/2) or Help Topics (Windows NT) from the Help menu.
- ◆ See the OS/2 manual “Using the Operating System” for additional information about the entire help system.
- ◆ See the Windows NT documentation for additional information about the entire help system.

The help menu

The help menu is the same on every window that has Help.

Press the F1 function key or use the help menu to get help information.

Shown here is the OS/2 help menu.

The Windows NT menu includes two selections a Help Topics selection and an About selection.

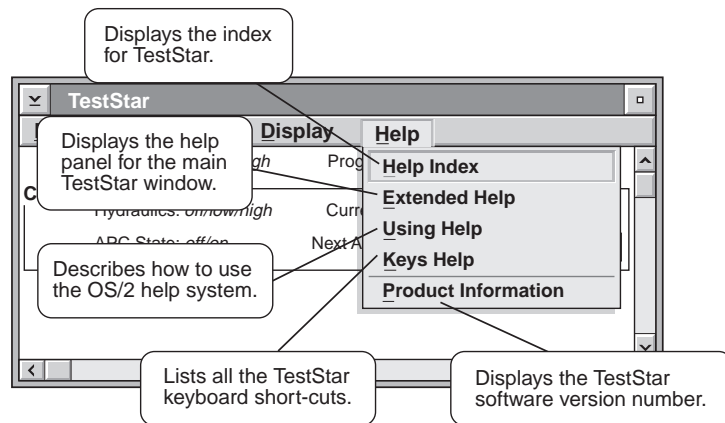

Note Pressing the F1 key on some windows displays the main TestStar window.

Calling for help

You can access TestStar help whenever a TestStar window is active. Press F1 to open the help for the active window. Some windows also include a Help menu or a Help pushbutton.

The following are the most common selections for on-line help. Review information about OS/2 for additional help information.

WINDOWS NT KEY	OS/2 KEY	MENU	SELECTION	FUNCTION
F1	F1	Help	Extended help	Opens help utility with the help panel for the active window.
	F10	Help	Help index	Lists all the help panels.
Alt C	Ctrl C	Options	Contents	Lists all the help panels according to the structure of the program.
Alt B	Esc	Options	Previous	Displays the previous help panel. Repeatedly using this function closes the help window and returns you to the active window.

The help window

The help window includes a help panel within it. The menu bar provides several functions for the help utility (see the User's Manual for detailed information about the help system).

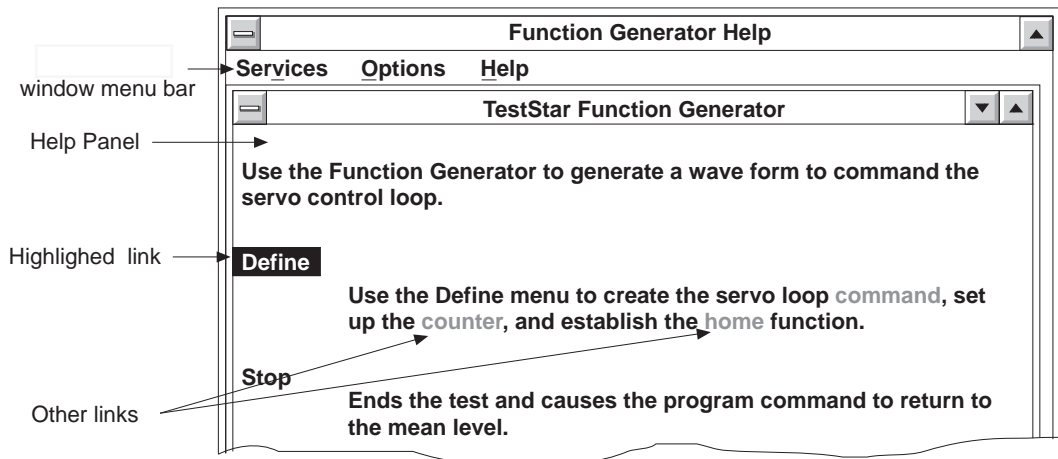

Using the Load Unit Control Panel

The load unit control panel (LUC or “Pod”) is located near, or mounted onto, the load unit.

The panel consists of a main module and up to 4 control channel modules.

The main module of the load unit control panel contains the controls and indicators that are common to all control channels.

One control channel module is added to the main module for each actuator in the test system.

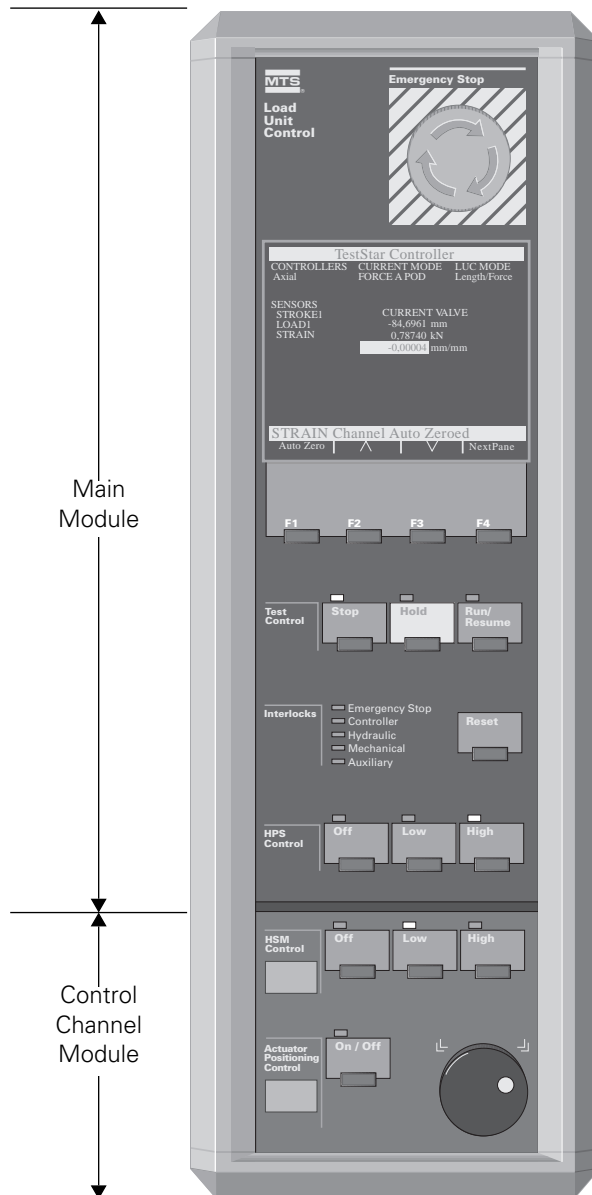

Main Module Controls and Indicators

Emergency Stop switch

Pressing this switch removes hydraulic pressure and stops the test program. The **Interlocks Emergency Stop** indicator then turns on.

To restore normal operation, reset the switch by twisting the knob as indicated by the arrows. Press the **Reset** switch to clear the interlock indicator.

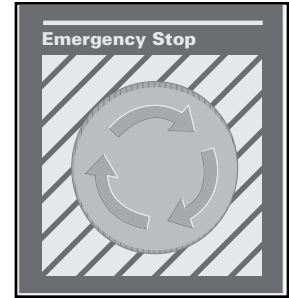

Test Control switches

A test can be started, held, or stopped either by the LUC switches...

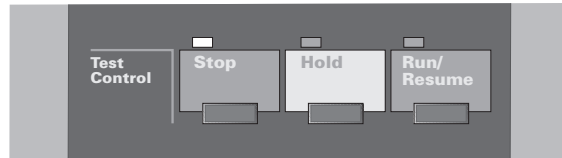

...or by the Function Generator pushbuttons.

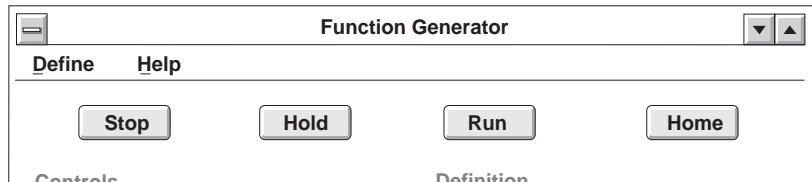

Interlocks

Interlocks cause the hydraulic pressure to be removed when specific events occur. Whenever an interlock becomes active, the cause of the interlock must be corrected before hydraulic pressure can be reapplied.

Refer to *Clearing a Detector* on page 54, for information on the names and causes of interlocks.

When the cause of an interlock is corrected, press the **Reset** switch to turn the interlock indicator off.

An interlock indicator lights when a problem is detected. The System Status window also pops up to display the interlock.

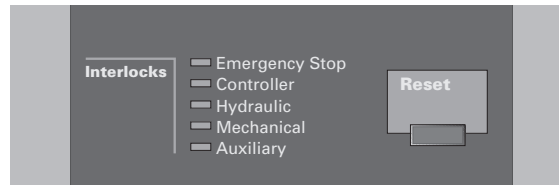

HPS Control

The HPS control switches control the hydraulic pressure of the hydraulic power supply. The HPS may supply hydraulic pressure to more than one load unit.

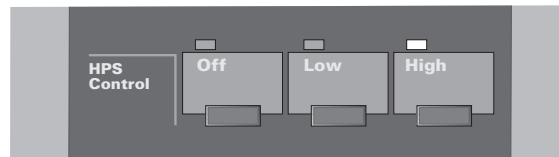

- ◆ **Off** – turns off the HPS.
- ◆ **Low** – turns on low hydraulic pressure, typically 2 MPa (300 psi).
- ◆ **High** – applies high hydraulic pressure, typically 21 MPa (3000 psi).

Display screen

The display screen shows key information that assists with installing and removing the specimen. The illustration below shows the normal screen supplied with each standard system.

Note You can create your own display screen using the Edit LUCP Display window. Go to Chapter 3 for more information.

This sample display shows:

- The current control mode is length. The "SG" stands for segment generator, which is normally the function generator.
- When system control is turned over to the LUC (or "Pod"), it will be in force mode.

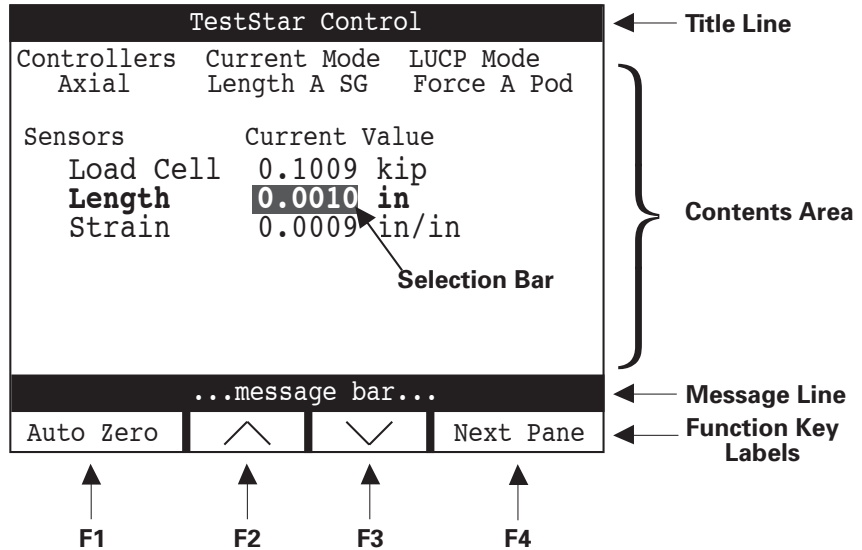

The default display shows the current control mode, the selected LUCP control mode, and the current output for each sensor.

Continued...

Display screen (continued)

Use the Display screen as follows:

FUNCTION KEY	FUNCTION
F1 When a sensor is selected...	Press F1 to Auto Zero the selected sensor. You can Auto Zero a sensor if it is not locked (this is set up in the Sensors window) and either of the following: <ul style="list-style-type: none"> ◆ Hydraulic power is off, or ◆ The selected sensor is not the feedback source for the existing LUC control mode. In the sample window shown on the preceding page, it would <i>not</i> be successful because a displacement sensor has been selected and the “Current Mode” is Length A SG.
When the LUC mode is selected...	The F1 label changes to Next Mode. Pressing F1 selects the next available defined LUC control mode. <p>Note <i>The LUC mode does not change until you actually press (to turn on) the Actuator Positioning Control switch. If the switch is already on when you change the LUC control mode, you need to set the switch off, then back on again for the mode change to be recognized.</i></p>
F2 and F3	Press either of these function keys to move the selection bar. This selection is indicated by reverse video. <p>Examples:</p> <ul style="list-style-type: none"> ◆ Press F2 to move the selection up. In the window shown on the previous page, this would select the sensor called Load Cell. ◆ If you press F2 a second time, you select the LUC mode control.
F4	Changes the display between pane 1 and pane 2 (if pane 2 is defined). See LUCP Display on page 131 to define the panes.

Control Channel Modules

A control channel module is added to the main module for *each* actuator in the test system.

Each axis of control requires one control channel module.

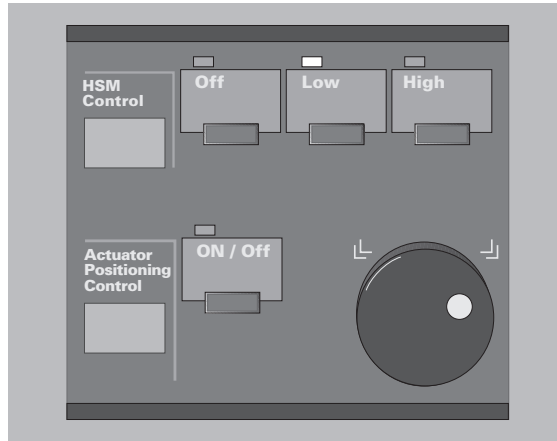

HSM Control switches

These switches control the hydraulic pressure of the hydraulic service manifold. Note that these switches affect pressure only at the test station being served by one manifold. The HPS must be on first.

- ◆ **Off** – turns off the HSM.
- ◆ **Low** – turns on low hydraulic pressure, typically 2 MPa (300 psi).
- ◆ **High** – applies high hydraulic pressure, typically 21 MPa (3000 psi).

Actuator Position Control

Pressing the APC switch enables the Actuator Positioning control knob and the selected LUC control mode. With hydraulic power on (HPS and HSM switches not set to Off), adjusting the control causes the actuator to extend or retract.

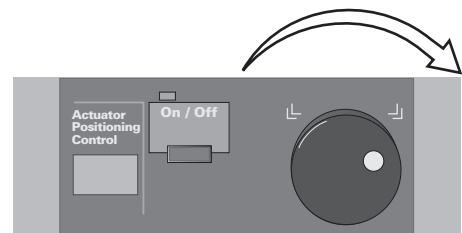

Clockwise = Retract Actuator

Module configurations

The control channel modules are available in three different configurations based on the capabilities of the hydraulic service manifold (also called HSM, actuator manifold, or station manifold).

- ◆ An HSM with Off, Low, and High pressure capabilities include switches and indicators for these functions.
- ◆ An HSM with Off/On pressure control do not include a Low pressure switch
- ◆ If an HSM is not used, no hydraulic switches are included.

LUC chassis configurations

Control channel modules added to the main module require different LUC chassis configurations.

LUC chassis configurations for 1, 2, 3, and 4 channels.

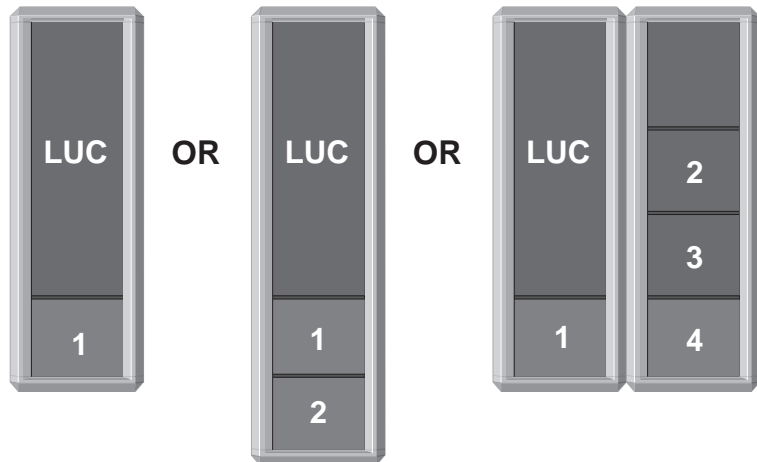



TestStarTM II

Control System

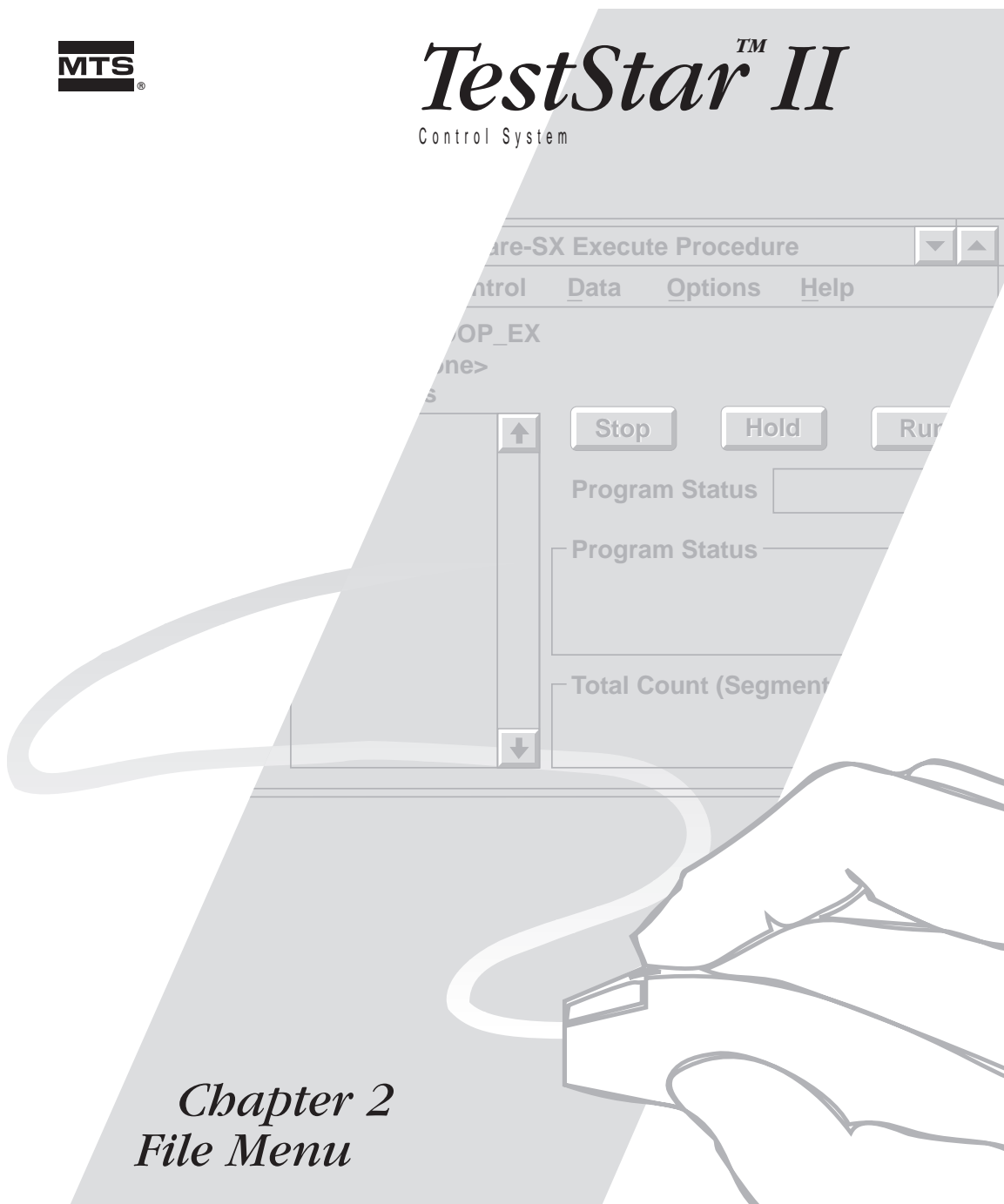

Chapter 2 File Menu

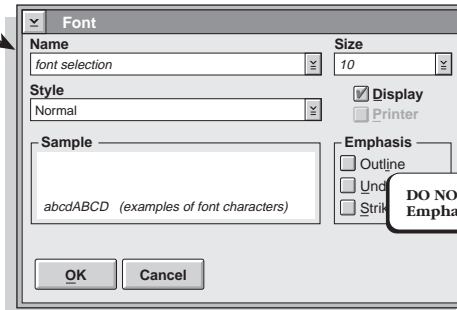
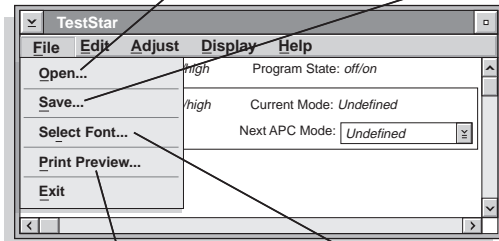
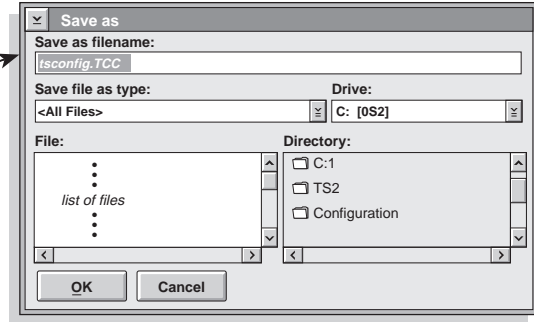
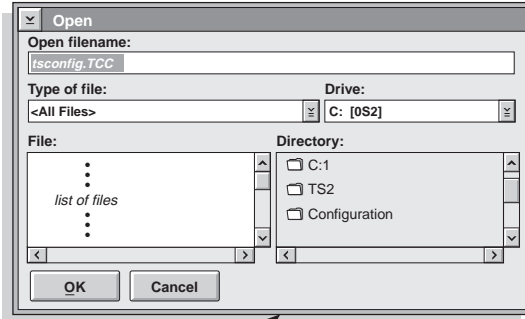

What you will see in this window depends on your TestStar settings and the Display settings for this window.

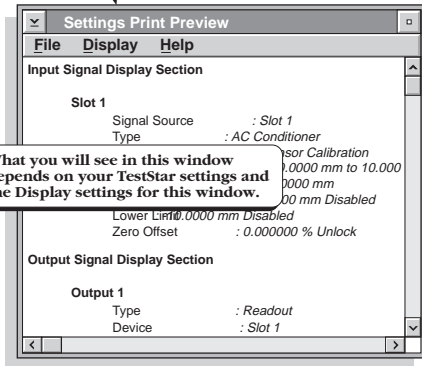

DO NOT use the Emphasis Settings.

Chapter 2

File Menu

The File menu provides the file management tools for the TestStar configuration files.

Note *The windows shown in this chapter vary slightly between the OS/2 and Windows NT versions.*

Contents

- [Open Window 72](#)
- [Save Window 74](#)
- [Select Font Window 76](#)
- [Print Preview Window 77](#)

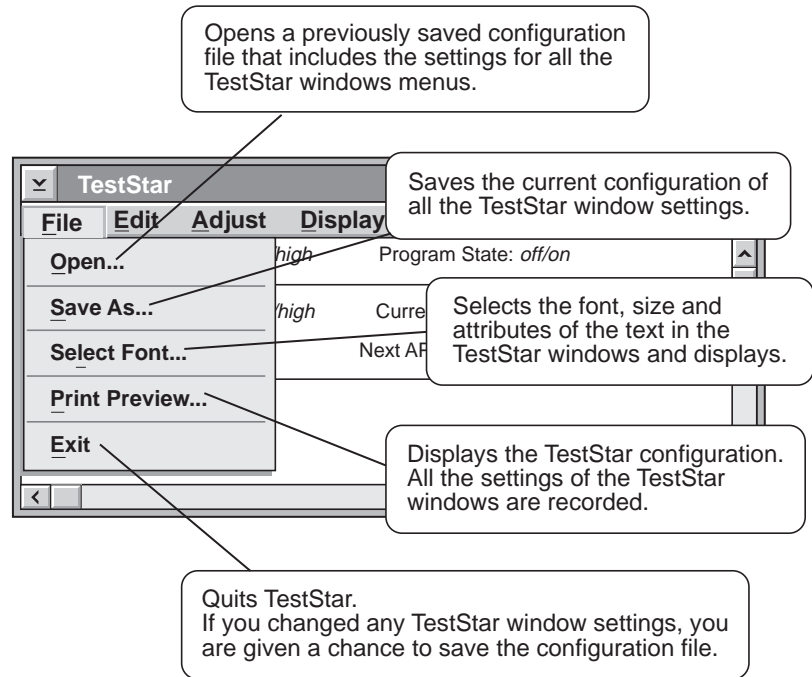



Open Window

Prerequisite

You must have a saved TestStar configuration file before you can use this window.

Use this window to open a TestStar configuration file.

The default path for this window is (C:\TS2\config).

Some systems have the default TS2 directory located on the D: drive.

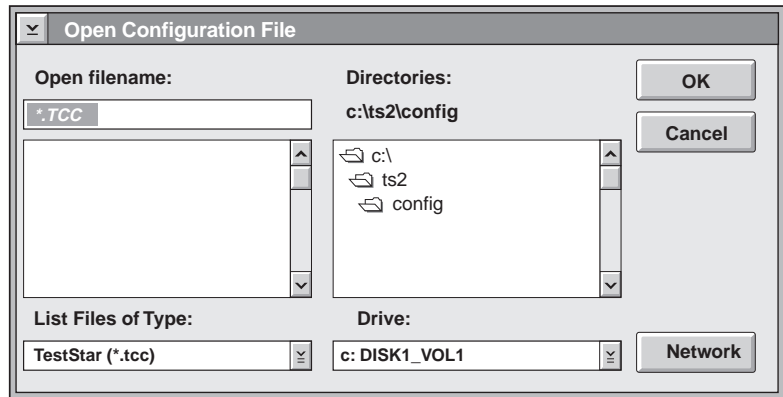

CONTROL

FUNCTION

Open filename

Displays ***.TCC** in the entry field. Type the name you want to call the configuration file here.

files

Lists the configuration files in the current directory. Selecting a file name displays it in the **File Name** entry field.

List Files of Type

Selects the type of files displayed in the File list. By default, <All Files> is selected. Select file type ***.TCC** to display only the files with the **.TCC** extension in the Files list.

Directories

Lists the available directories for the selected drive. Double-clicking a different directory displays the files of the directory in the **Files** list and any other directories in the **Directories** list.

Drive

Displays the current drive. All root directories of the drive are listed in the **Directories** list.

Network (Windows NT only)

Pressing the **Network** button displays the Connect Network Drive window where you can define new network drives and paths.

Using the window

Be sure you know where you saved your configuration files. The default path for this window is (C:\TS2\config).

Note We recommend that you have a configuration file for each type test you perform. Each user can have a configuration file automatically open when they log into TestStar and they can change it once they are logged in.

1. Use the list icon for the Drive field to select the drive where your configuration files are located.

In this case the C: drive should be displayed.

2. Double-click the desired directory in the Directory list, this causes all its files to be displayed in the Files list and it also displays any additional directories.

In this case the Config directory in the TS2 directory should be displayed.

3. Select the TestStar configuration file you want to open from the File list. The selection will be displayed in the Open filename field.
 4. Press the OK button to open the file.
-



Save Window

Use this window to save a TestStar configuration file.

The default path for this window is (C:\TS2\config).

Some systems have the default TS2 directory located on the D: drive.

We recommend you save a configuration file for each type of test you run.

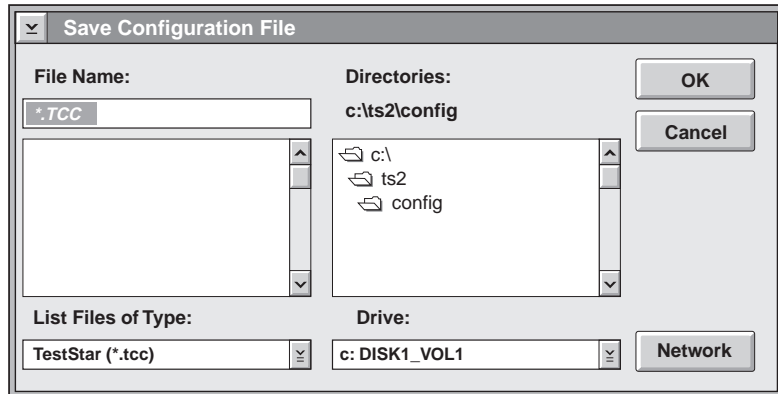

CONTROL

FUNCTION

File Name

Displays *.TCC in the entry field. Type the name you want to call the configuration file here.

Files

Lists the configuration files in the current directory. Selecting a file name displays it in the **File Name** entry field.

List Files of Type

Selects the type of files displayed in the File list. By default, <All Files> is selected. Select file type *.TCC to display only the files with the .TCC extension in the Files list.

Directories

Lists the available directories for the selected drive. Double-clicking a different directory displays the files of the directory in the **Files** list and any other directories in the **Directories** list.

Drive

Displays the current drive. All root directories of the drive are listed in the **Directories** list.

Network (Windows NT only)

Pressing the **Network** button displays the Connect Network Drive window where you can define new network drives and paths.

Using the window

Be sure you know where you want to save your configuration files. The default path for this window is (C:\TS2\config).

Note We recommend that you have a configuration file for each type test you perform. Each user can have a configuration file automatically open when they log into TestStar and they can change it once they are logged in.

You can't save a configuration file while another TestStar or TestWare application is running.

1. Use the list icon for the Drive field to select the drive where you save configuration files.

In this case the C: drive should be displayed.

2. Double-click the desired directory in the Directory list, this causes all its files to be displayed in the Files list and it also displays any additional directories.

In this case the Config directory in the TS2 directory should be displayed.

3. Type a file name in the **Save as filename** entry field (the .TCC extension is automatically added).
 4. Press the OK button to save the file.
-



Select Font Window

This is a standard OS/2 window. The Windows NT window looks similar. It allows you to customize the text of the TestStar windows.

Use this window to select a font for the text in the TestStar windows.

This window also appears when you want to change the font in the Print Preview window.

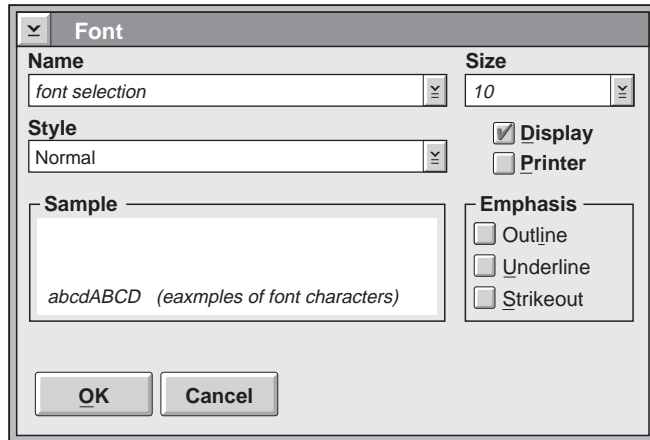

CONTROL	FUNCTION
Name	Selects the font for text in the TestStar windows.
Size	Selects the point size of the font.
Style	Applies normal, <i>italic</i> , bold , or bold italic to the selected font. Use a style that is easy to view such as normal or bold.
Sample	Displays the selected font, size and style so you can see what it looks like before you assign it.
Emphasis (OS/2 only)	Applies outline, <u>underline</u> , and/or strikeout to the selected font. DO NOT use these selections. The TestStar text would become unreadable.



Print Preview Window

All of the TestStar configuration information available to this window is established with the Edit menu.

Use the this window to view a summary of the current TestStar configuration in an outline format.

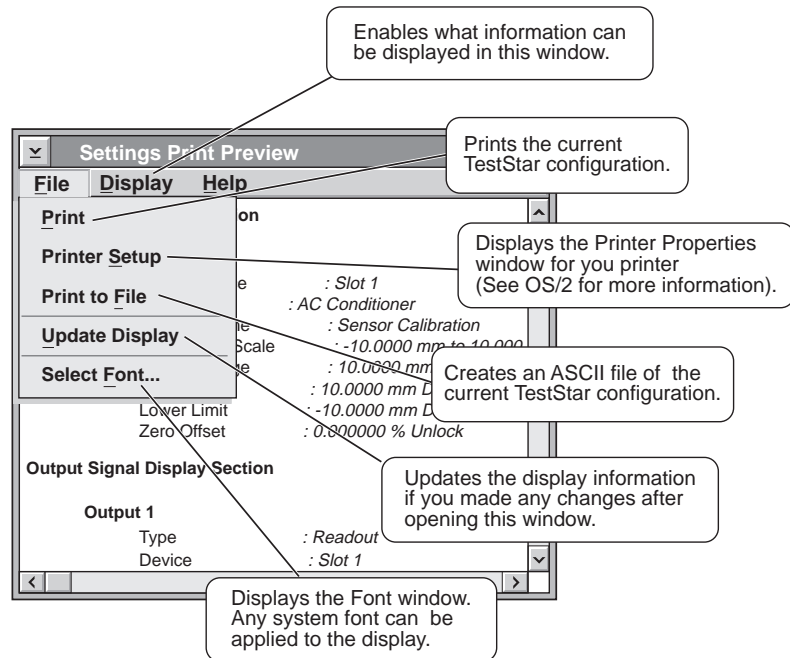

Display menu

Use the Display menu to select the parameters you want to display. Enable each item you want to view, a check mark indicates the item can be viewed. These settings also affect the information that is printed or saved to a file.

Note Anytime the configuration file is changed, the Configuration File listing shows "configuration modified."

Configuration format

The following shows a generic outline of the types of information that is shown in the Print Preview window, saved to an ASCII file, or printed.

Configuration File Name: C:\ts2\Config\default.tcc
Software Version: 3.1A
Printout Date: 11-07-1994 02:25:21 PM

- Display
- ✓ System Information
- Input Signals
- Output Signals
- Control Channels
- Constants
- Actions

System Information
Extended AIO: No
High Speed Data Acquisition: No
Update Rate: 5000 Hz
Load Path Stiffness Set : <<No Correction>>

- Display
- System Information
- ✓ Input Signals
- Output Signals
- Control Channels
- Constants
- Actions

Input Signal Display Section
stroke
Signal Source : Slot 1
Type: AC Conditioner
Sensor Name : STROKE1
Sensor Full Scale : -127.000 mm - 127.000 mm
Sensor Range: 127.000 mm
Upper Limit : 127.000 mm Disabled
Lower Limit : -127.000 mm Disabled
Zero Offset : 0.00000 % Unlock

load
Signal Source : Slot 2
Type: DC Conditioner
Sensor Name : FORCE_20KIP
Sensor Full Scale : -88964.4 N to 88964.4 N
Sensor Range: 88964.4 N
Upper Limit : 88964.4 N Disabled
Lower Limit : -88964.4 N Disabled
Zero Offset : 0.00000 % Unlock

Calculated 1
Signal Source : Calculated 1
Type: Calculation
Calculation Range : -1.0000 mm to 1.0000 mm
Upper Limit : 1.0000 mm Disabled
Lower Limit : -1.0000 mm Disabled
Equation: ={\Pi}*power({radius},2)

Display

- System Information
- Input Signals
- ✓ Output Signals
- Control Channels
- Constants
- Actions

Output Signal Display Section

Output 1
 Type: Analog Bus
 Device : stroke: Conditioner
 Signal : Transducer

Output 2
 Type : Readout
 Device : axial: Valve
 Scale : 1.0000 V
 Offset: : 0.00000 V

Display

- System Information
- Input Signals
- Output Signals
- ✓ Control Channels
- Constants
- Actions

Control Channel Display Section

axial

Channel	: Control Channel 1
Drive Type	: 252 Valve
Valve Driver	
Valve Type	: 252 Valve
Valve Balance A	: 0.00000
Dither Amplitude	: 0.10000
Dither Frequency	: 625.000

Underpeak Detectors
 Input Signal : Undefined

Error Actions
 Maximum Error Action: Disabled
 Minimum Error Action: Disabled

stroke control

Mode	: Control Mode 1
Mode Type	: PIDF
Command	: Segment Generator
Feedback	: stroke
Gain	
P	: 1.0000
I	: 0.00000
D	: 0.00000
F	: 0.00000

Error Detectors
 Minimum Error : 127.000
 Maximum Error : 127.000

Pod control

Mode	: Control Mode 4
Mode Type	: Channel Limited Channel
Command	: Pod
Feedback	: stroke
Limit Feedback	: load
Gain	
Master P	: 1.0000
Limit P	: 1.0000
Upper Limit	: 88964.4 N
Lower Limit	: -88964.4 N

```

cascade control
  Mode           : Control Mode 7
  Mode Type      : CASC
  Command        : Segment Generator
  Outer Loop Feedback : stroke
  Inner Loop Feedback : load
  Gain
    Outer Loop P: 1.0000
    Outer Loop D: 0.00000
    Inner Loop P: 0.00000
    Inner Loop I: 0.00000
  Error Detectors
    Minimum Error : 127.000
    Maximum Error : 127.000

```

Compensators

```

Peak/Valley
  Convergence Rate : 1.00000
  Limit            : 100.000

```

Display

- System Information
- Input Signals
- Output Signals
- Control Channels
- ✓ Constants
- Actions

Calculation Constant Section

```

Pi
  Value           : 3.1400 (none)

Radius
  Value           : 12.5 mm

Modulus
  Value           : 10 MPa

```

Display

- System Information
- Input Signals
- Output Signals
- Control Channels
- Constants
- ✓ Actions

Action Display Section

```

Disabled
  Type: Disabled

Indicate
  Type: Indicate

Hydraulics Off
  Type: Hydraulics Off

Interlock
  Type: Interlock

Return to Zero
  Type: Ramp

```



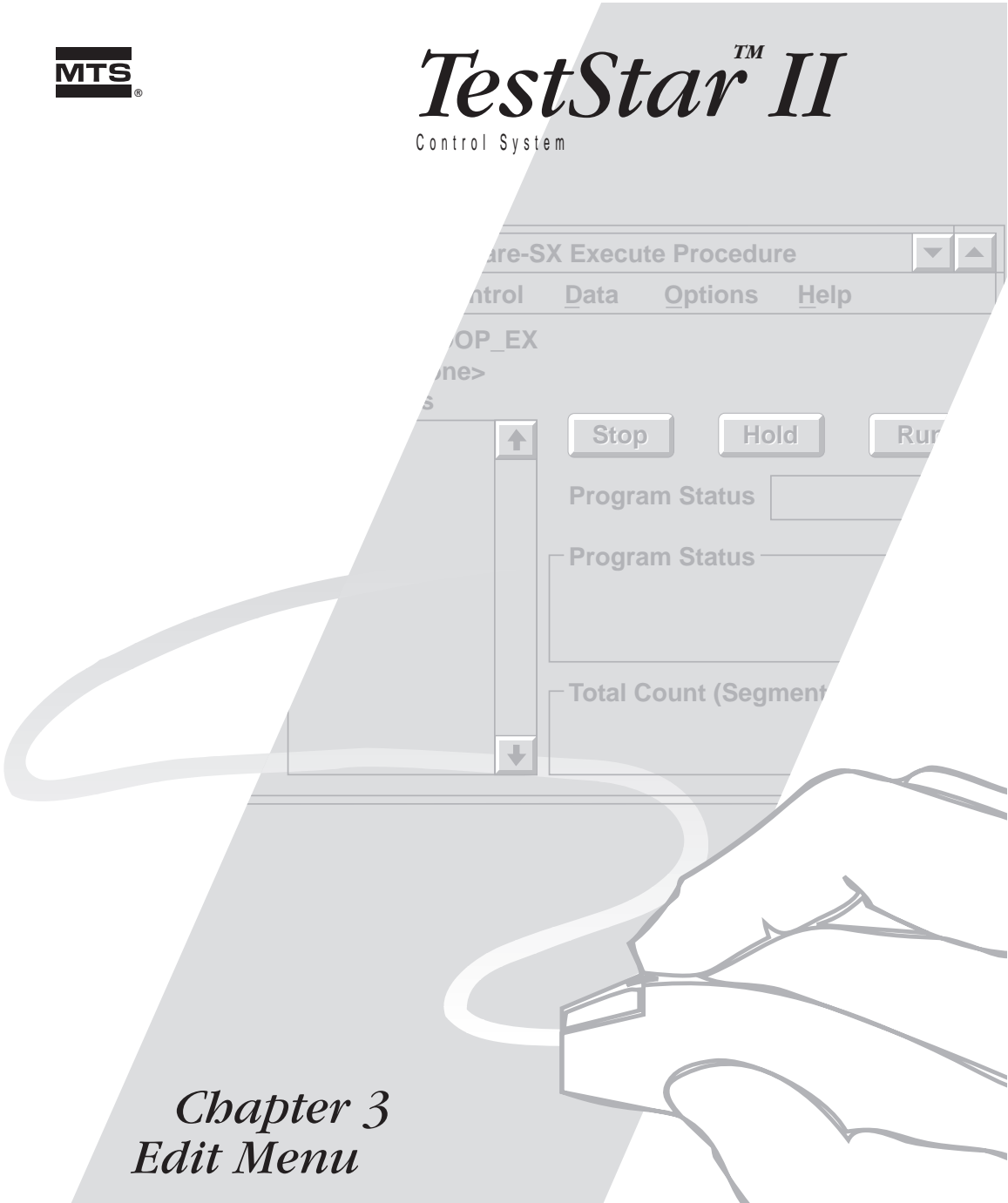

TestStarTM II

Control System

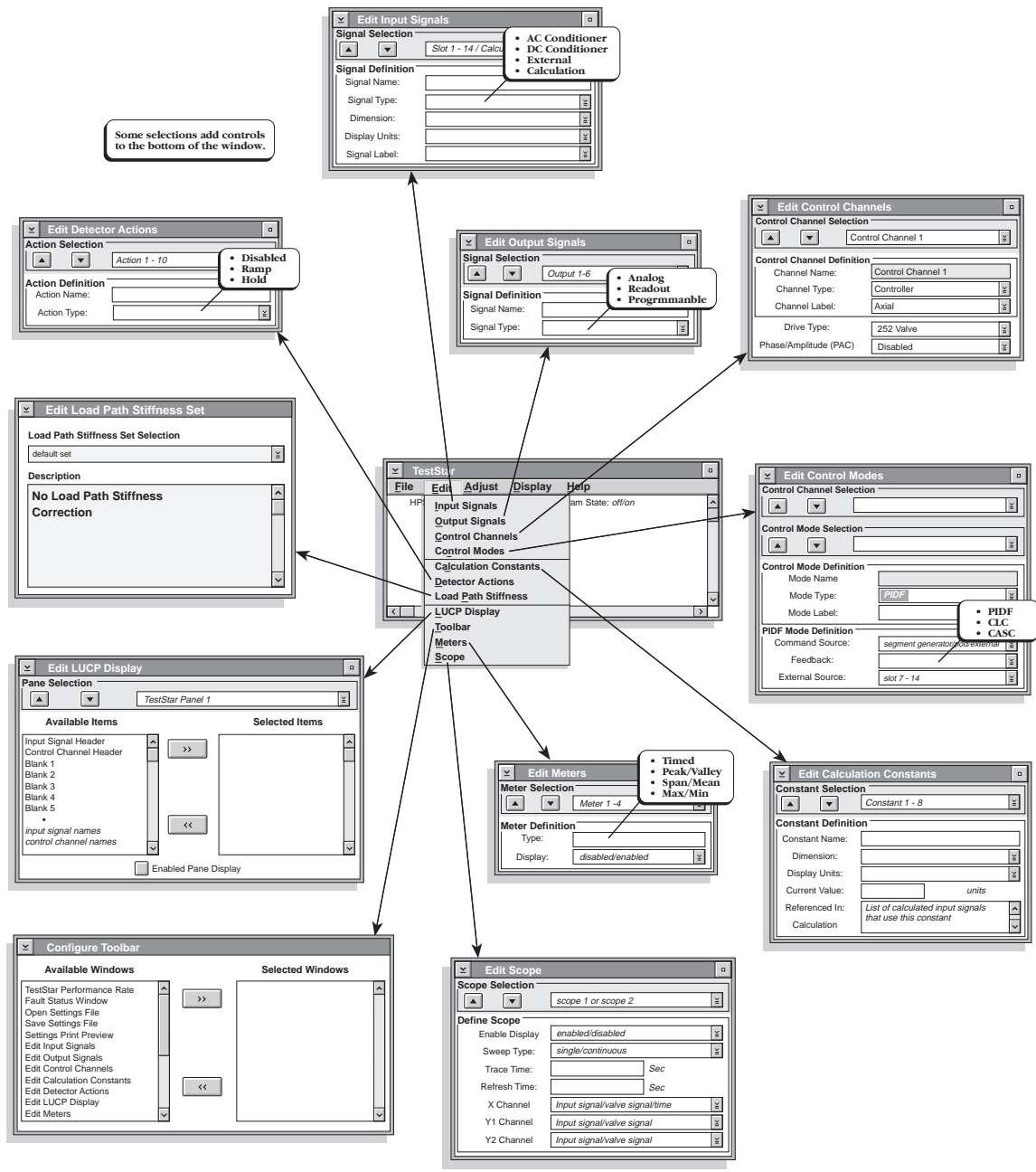

Chapter 3 Edit Menu



Chapter 3

Edit Menu

Contents	Input Signals	85
	Edit Input Signals Window	88
	AC & DC Conditioner Signal Type	90
	External Signal Types	91
	Calculation Signal Types	93
	Assign Sensor Window	96
	Define External Sensor Window	97
	Output Signals	99
	Edit Output Signals Window	101
	Analog Bus	103
	Readout	105
	Programmable Output	109
	Control Channels	110
	Edit Control Channels Window	112
	Control Modes	116
	PIDF Control Mode	118
	Channel Limited Channel Control Mode	120
	Cascade Control Mode	121
	Calculation Constants	122
	Detector Actions	124
	Edit Detector Actions Window	126
	Hold Actions	127
	Ramp Actions	128

Continued...

Contents (continued)

- Load Path Stiffness 129**
 - Edit Load Path Stiffness Window 130**
- LUCP Display 131**
- Toolbar 133**
 - Configure Toolbar Window 134**
- Meters 136**
 - Meter Definition Window 137**
- Timed Data 138**
- Peak/Valley Data 139**
- Span/Mean Data 140**
- Max/Min Data 141**
- Scope 142**

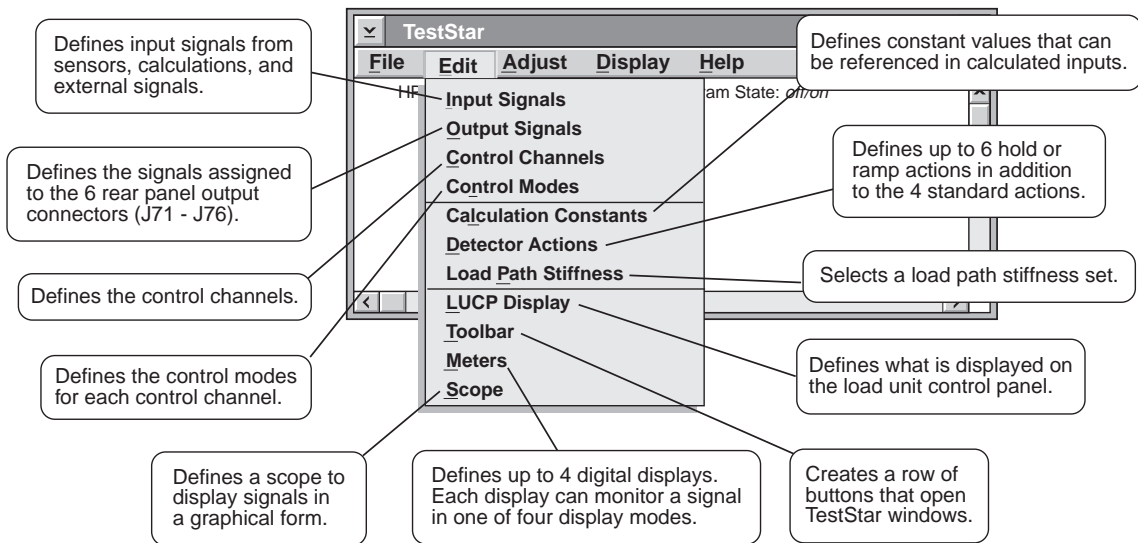



Input Signals

Input signals are from sensors (transducers). Each sensor signal must be defined for use with TestStar. You need to know the following to define an input signal:

- ◆ What type of sensor are you defining (ac, dc, external, calculated)?
 - ◆ Where is the sensor connected to the digital controller?
 - ◆ Has the sensor been calibrated with the Sensor Calibration program?
-

Types of sensors

Determine what type of sensor you are going to define. Knowing the type of sensor helps you determine the appropriate dimension (such as length, force, and angle) for the sensor and your preference for display units.

Knowing the type of sensor helps you determine the signal type. The sensor signal can be processed (conditioned) by an ac or dc conditioner plugged into the digital controller or by a conditioner located somewhere else. TestStar supports four types of sensor signals.

- ◆ An **ac conditioner** signal type is conditioned by a Model 490.22 AC Conditioner plugged into the digital controller.
- ◆ A **dc conditioner** signal type is conditioned by a Model 490.21 DC Conditioner plugged into the digital controller.
- ◆ An **external** signal type is conditioned outside the digital controller.

An internal or external signal type can have additional signal processing applied in the form of a mathematical formula.

- ◆ A **calculated input** signal type uses one or more defined input signals and calculates a new signal according to a formula you create.
-

Signal connection

All sensor signals are input to a rear panel connector. Each input signal is assigned a slot.

Knowing where the signal is connected to the digital controller, you can determine the slot location number that is assigned to the sensor input.

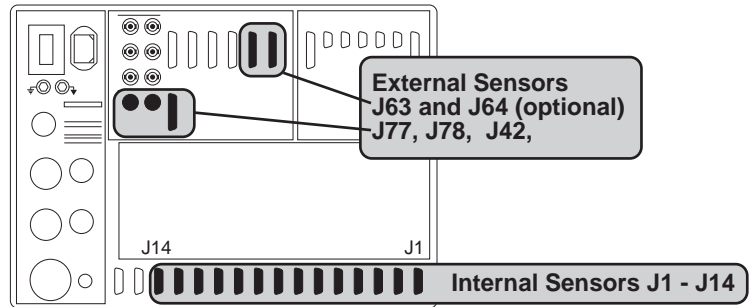

- ◆ Slots 1 through 14 correspond with connectors J1 - J14 when using internal sensor signals.
- ◆ Connectors J77 and J78 correspond with slots 13 and 14.
- ◆ Expanded Inputs 1 - 16 correspond with the external inputs at J63 and J64 (see Extended Analog I/O in Chapter 2 of the Installation manual).

Sensor calibration

You have access only to calibrated sensors that are included in your data base. There are two ways to add a sensor to your data base:

- ◆ Using the sensor calibration program to calibrate a sensor.
- ◆ Loading calibration data from a disk – this could be from a sensor calibrated at MTS or from your archives.

The sensor calibration program creates a data base record for each sensor that is calibrated. Each data base includes all the ranges that were calibrated for the sensor. Each sensor can have up to six ranges. Go to the Installation manual for the following procedures.

Detailed calibration procedures

- | | |
|-------------------|---|
| Chapter 6 | Calibrating an LVDT |
| Chapter 7 | Calibrating a force sensor |
| Chapter 8 | Calibrating an extensometer |
| Chapter 9 | Printing, backing up, and retrieving calibration data |
| Chapter 10 | Defining external sensors |

Sensor cartridges

The 490.21 DC Conditioner has a front panel connector for a sensor cartridge. Each sensor cartridge provides a place to install up to five shunt calibration resistors and three bridge completion resistors for a sensor. Each dc type sensor should have a sensor cartridge for the dc conditioner.

The shunt cal resistors are used to check the calibration accuracy of the sensor/conditioner combination. The sensor cartridge **must** be installed when performing a shunt calibration operation. Otherwise, it is not required for normal operation.

The bridge completion resistors allow the use of quarter- and half-bridge strain gage sensors. The sensor cartridge **must** be installed when using this type of sensor, it is required for normal operation.

More information

Cabling	<i>Installation Manual (3)</i>
Calibrating sensors	<i>Installation Manual (6 7, 8)</i>
Selecting a range	<i>Edit Input Signals Window</i> on page 88 <i>Adjust Input Signals Window</i> on page 149 <i>Display Input Signals</i> on page 190
Setting up external sensors	<i>Installation Manual (10)</i>
Setting limits to input signals	<i>Upper and lower limits</i> on page 151
Sensor cartridge shunt cal resistors	<i>Installation Manual (2)</i>
Sensor cartridge bridge completion resistors	<i>Installation Manual (2)</i>



Edit Input Signals Window

Input signals need to be defined when sensors are added to your system or existing sensors are changed.

Use this window to define input signals.

Controls are added to the bottom of the window according to the Signal Type selection.

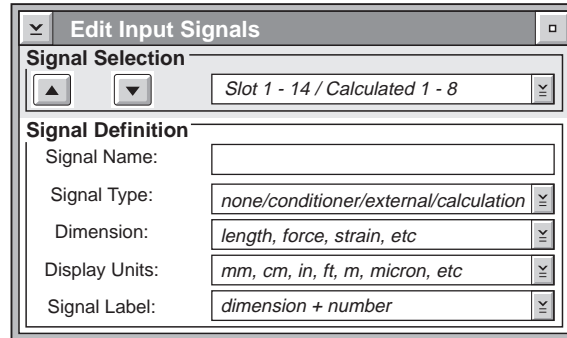

CONTROL	FUNCTION
Signal Selection	Assigns the sensor to one of the 14 slot locations (which correspond with the plug-in modules) or creates one of the 8 possible calculated inputs. Up to 22 input signals can be defined.
Signal Name	Names the input signal. The name you enter is used throughout the TestStar windows to identify this input signal. Enter any name you wish. The default name is the same as the Signal Selection name.
Signal Type	Specifies the type of signal to define. Controls needed to define the selection are added at the bottom of this window. <ul style="list-style-type: none"> None Indicates that an input signal is not assigned or no module is plugged into the slot location of the Signal Selection. AC Conditioner Use this selection to define a sensor connected to an ac or dc conditioner. DC Conditioner TestStar checks the type of module plugged into the slot location and lists it as the only selection. See AC & DC Conditioner Signal Type on page 90. External Use this selection to define a sensor signal from an external conditioner. This selection is available for slot locations 7 - 14 only. See External Signal Types on page 91. Calculation Use this selection to define an input signal that has a mathematical equation applied to a signal. This selection is only available for a Calculated Signal Selection. See Calculation Signal Types on page 93. The calculation feature may be used without an input signal (see Calculation Constants on page 122).

CONTROL	FUNCTION
Dimension	Assigns the type of units for this signal. Select an appropriate dimension for the signal. Only sensors that match the dimension are available.
Display Units	Selects the specific units you want to assign to the sensor signal. The selected dimension determines what units are available.
Signal Label	Specifies a number to distinguish input signals of the same dimension. TestStar uses this label internally to identify the input signal internally.

Using the window

1. Select a slot location or calculated input in the Signal Selection area. This selection determines the Signal Type selections.
2. Enter a Signal Name if you want; otherwise, the Signal Selection text is used.
3. Select a Signal Type. Most of the time a single selection is available; the exception is when a module is installed in one of the slots 7-14. These locations can support ac/dc conditioners and external inputs.
4. Select a dimension. The default selection is Length.
5. Select your preference for Display Units. The units selection is shown anywhere the signal is used within TestStar or any TestWare application.
6. TestStar chooses a Signal Label. You may change it if you need to match input signals and configurations with other TestStar systems.



AC & DC Conditioner Signal Type

When you select an AC Conditioner or DC Conditioner signal type you will see this window configuration.

Use the Assign Sensor button to select a calibrated sensor.

Use the list icon to select a Range from the list of calibrated ranges.

Note The sensor you assign should be connected to the rear panel connector (J1 - J14) that corresponds with the module (slot) location of the ac or dc conditioner.

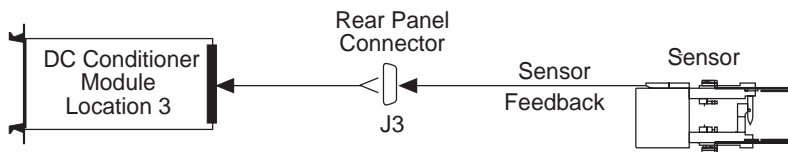

Assign Sensor

The sensors available match the Dimension selection. If you do not see the sensor you are looking for, check the Dimension selection in the Edit Input Signals window. See the Assign Sensor window description for more information.

When you press the Assign Sensor button this window opens.



External Signal Types

The external signal type applies to both external feedback and external command sources. These inputs may be used differently but the signal interface is the same.

- ◆ An external feedback signal can be input from a conditioner that is not located in the TestStar chassis.
- ◆ An external command source can be from a function generator or other program source that is not part of TestStar.
- ◆ An optional Extended Analog I/O hardware package offers sixteen additional external inputs. If you have this option you will have additional Signal Selections labeled Extended 1 - 16. See Chapter 2 in the Installation manual for detailed information about the Extended Analog I/O option.

Note Detailed instructions to install and define an external sensor or external command can be found in Chapter 10 of the Installation manual.

When you select the External signal type you will see this window configuration.

Use the **Assign Sensor** button to select an external sensor from the calibrated sensor data base.

Use the **Assign Temporary** button to set up a temporary calibration file.

Use the list icon to select a **Range** from the list of calibrated ranges.

How it works

The sensor you assign should be connected to a rear panel connector (J77, J78, or J42) that corresponds with a module location (slots 7 - 14). Rear panel connectors J63 and J64 are associated with the optional Extended 1 - 16 selections.

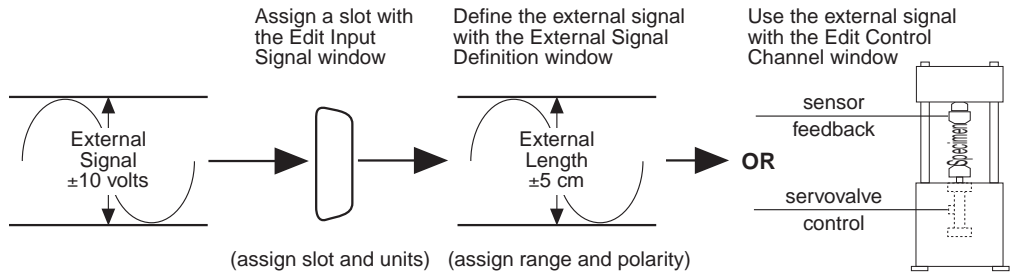

Assign Sensor

The sensors available match the Dimension selection. If you do not see the sensor you are looking for, check the Dimension selection in the Edit Input Signals window. See the Assign Sensor window description for more information.

When you press the Assign Sensor button this window opens.

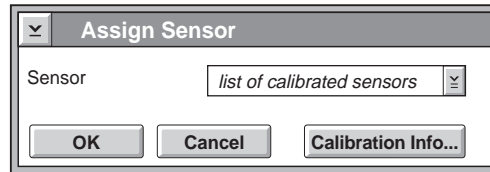

Assign Temporary

Use this window if you have not defined an external signal with the Sensor Calibration program. The information in this window is saved with the TestStar configuration file. See the Define External Sensor window description for more information.

When you press the Assign Temporary button this window opens.

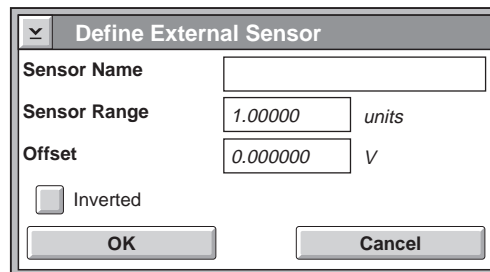



Calculation Signal Types

When you select the calculation signal type, you assign a formula to one or more input signals to create a unique calculated input signal. A calculated input signal applies the equation to each sample of the input signal.

Note *Calculated input signals require processing time from the digital controller. This reduces the maximum servo loop update rate and the maximum test frequency range available to you.*

A calculation signal type can also be used as a calculated constant (see [Calculation Constants](#) on page 122).

When you select the Calculation signal type you will see this window configuration.

Use the calculation area to express a formula.

A calculation always starts with the equal symbol (=).

Use the algebraic rules that you learned in school so long ago.

Also, use only SI units.

⚠ WARNING

Using a flawed calculated input in a control mode can cause unexpected actuator movement that can injure someone or damage equipment.

Be sure your calculation contains no errors or unworkable algebraic expressions.

Functions

Use the operators =, +, -, *, and / with the following math functions.

FUNCTION	DESCRIPTION
arccos(x)	Returns the arc cosine of x; x is in radians. Domain: -12868.0, 12868.0 Range: -1.0, 1.0
arcsin(x)	Returns the arc sine of x; x is in radians. Domain: -12868.0, 12868.0 Range: -1.0, 1.0
arctan(x)	Returns the arc tangent of x; x is in radians. Domain: -6434.0, 6434.0 Range: $-\infty$, $+\infty$
avg(y,x)	Returns the last x samples of input signal. Y can be any input signal (including calculated inputs) or variable constant. X can be 1 to 100. This cannot be used with other functions.
{constants}	Constants should be defined with the Edit Calculation Constants window. A constant is always entered with curly braces {constant name}.
cos(x)	Returns the cosine of x; x is in radians. Domain: -12868.0, 12868.0 Range: -1.0, 1.0
exp(x)	Returns e^x Domain: $-\infty$, +88.72 Range: 0.0, $+\infty$
ln(x)	Returns the natural log $\ln(x)$ Domain: 0.0, 3.4^{38} Range: -103.28, 88.72
log(x)	Returns $\log_{10}(x)$ Domain: 0.0, 3.4^{38} Range: -44.85, 38.53
power(x,y)	Returns x^y . Domain: $x > 0.0$, $+\infty$, $y[-\infty, +\infty]$ Range: $-\infty$, $+\infty$
prev(x)	A special function that returns the input x (input signal) and stores the last 100 samples of that signal in a circular buffer. The stored samples may be accessed in an indexed mode using braces "[x]" (where x is the sample to be indexed). This cannot be used with other functions.
{Input Signal Name}	The signal name defined in the Input Signals Definition window. A signal name is always entered with curly braces {signal name}.
round(x)	Rounds off the value of x.
sin(x)	Returns the sine of x; x is in radians. Domain: -12868.0, 12868.0 Range: -1.0, 1.0
tan(x)	Returns the tangent of x; x is in radians. Domain: -6434.0, 6434.0 Range: $-\infty$, $+\infty$
time	Increments at the servo loop update rate. Time is always entered with curly braces {time}. The clock is reset when the Function Generator or TestWare-SX program is started. A command to reset the clock is available for those who program.
trunc(x)	Truncates the value of x.
[x]	Brackets identify a variable array.

Examples

⚠ CAUTION

Here are some examples of formulas that create a calibrated input.

Define all constants with the Calculation Constants feature (see [Calculation Constants](#) on page 122 for additional information.)

If you do not use the Calculation Constants feature, the constant will assume the units of the SI metric unit assignment set (you will not have control of the units.)

Area

This example calculates the area of a cross section of a specimen. Area could be represented as a calculation constant or a constant value instead of a calculation.

$$={\mathbf{Pi}} * \mathbf{power} ({\mathbf{radius}},2)$$

Where: *Pi* is a calculation constant.
radius is a calculation constant that represents half the diameter of the specimen's cross section.

Axial Stress

This example divides the force input signal by the area of the specimen.

$$={\mathbf{Load}} / {\mathbf{Area}}$$

Where: *Load* is the name of a force sensor input signal.
Area is a calculation constant or the calculation above (a specific value may also be used in place of the name).

Average Strain

This example adds three input signals and divides them to produce an average signal.

$$={({\mathbf{Strain 1}} + {\mathbf{Strain 2}} + {\mathbf{Strain 3}})/3$$

Where: *Strain 1, 2, and 3* are three different strain input signals.

True Strain

This example shows how to calculate true strain.

$$={\mathbf{ln}} ({\mathbf{strain}} + 1)$$

Where: *ln* is the natural log function (see *the functions table*).
Strain is the strain input signal.

Corrected Axial Strain

This example references another calculation and a calculation constant.

$$={\mathbf{Axial Strain}} - ({\mathbf{Axial Stress}}/{\mathbf{Modulus}})$$

Where: *Axial Stress* is the result of another calculation
Modulus is a calculation constant.

Assign Sensor Window

Prerequisite

You must have a data base of calibrated sensors, otherwise you must calibrate a sensor. The sensor data base is established and maintained with the Sensor Calibration program (see Chapters 6 - 9 in the Installation manual).

Use this window to select a sensor from your sensor data base.

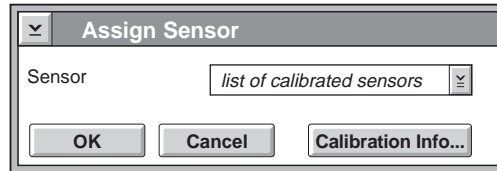

CONTROL

FUNCTION

Sensor

Select the sensor you want assigned to the input signal. Only calibrated sensors matching the selected dimension are displayed. Be sure the sensor is connected to the rear panel connector that is associated with the input signal slot selection.

The Sensor Calibration selection lets you calibrate a sensor for the first time.

Calibration Info

Displays some of the sensor calibration information entered with the Sensor Calibration program.

Calibration Info...

This window displays basic information about the selected sensor. The information is recorded when the sensor is calibrated.

Pressing the Calibration Info button opens this window

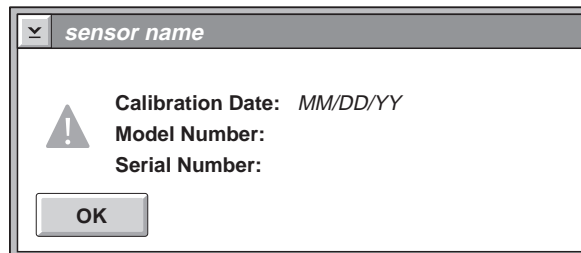

Define External Sensor Window

An external sensor is a sensor signal that is conditioned by another control system.

- ◆ As an external sensor, the signal **does not** use a Model 490.21 DC Conditioner or a Model 490.22 AC Conditioner.
- ◆ As an external command source, the signal is from a remote program device such as a function generator or profiler.

Note See the *Installation manual, Chapter 10* for detailed information about connecting and defining external sensors.

Prerequisite

You must be defining or editing an external input signal to reach this window. The external signal must be within ± 10 volts.

Use this window to define an external signal from another control system without defining an external signal with the sensor calibration program.

CONTROL	FUNCTION
Sensor Name	Names the external signal. Call it anything you want.
Sensor Range	Defines the range of the input signal. Enter a value that defines 10 volts. The units are assigned in the Edit Input Signals window.
Offset	Specifies an electrical offset (in volts) that is applied to the external sensor signal.
Inverted	Reverses the polarity of the input signal.

Range

For example, assume the external sensor is measuring length. If the full scale output of the sensor represents 75 mm, then enter 75 as the Range and select mm for the Range Units. This is a 100% range.

Another example, assume you are using the same sensor as above and your test will operate within ± 10 mm and the external conditioner can select different ranges. You may enter a value smaller than the full scale output but larger than the expected output. In this case you could enter a value that matches the range of the external conditioner.

Offset

A calibrated sensor output from an external conditioner may change due to cable length/resistance or environmental factors.

1. Set up the external conditioner to provide a null output.
2. Monitor the external conditioner null signal with the Sensor Output value in the Adjust Input Signals window or the Display Input Signals window.
3. The Sensor Output value should also be null. If not, record the difference.
4. If necessary, enter the signal difference using the opposite polarity into the Offset entry field.



Output Signals

Output signals are from input signals, conditioner modules, valve driver modules, and optional TestWare applications that can program the output. You need to know the following to define an output signal:

- ◆ The capabilities of the external device.
- ◆ Where the external device is connected.

If you have any questions about the external device, check the product manual that came with the external device for assistance.

About the external device

The first thing you need to do is to decide what kind of device you want to connect. Output signals can be configured for either of two types of devices.

- ◆ A monitor device such as a meter, oscilloscope, or x/y recorder can display an output signal. A monitor device uses a readout or analog bus type of output signal.
- ◆ A control device such as a temperature controller uses the output signal as a command source. A control device uses a programmable type of output signal.

Note *The programmable output signal is not used with standard TestStar but is used with optional applications such as the Analog Output process in TestWare-SX.*

You also need to know the range of the voltage that the external device can receive. The TestStar output signal can be scaled within ± 10 volts. Knowing this will help you determine how to scale the output for the external device input.

Signal connection

All signals that can be monitored are output through rear panel connectors. Knowing where the external device is connected to the digital controller helps you determine a DAC number to assign to the signal.

Labels such as

Output 1 - 6,
Readout 1-6 and
DAC 1 - 6

all correspond with each other.

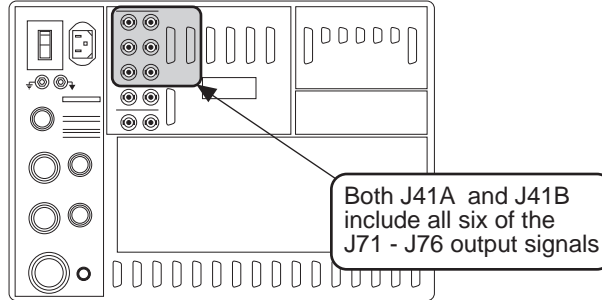

More information

Cabling

Installation Manual (3)

Programmable outputs *Any application that uses one describes its use*



Edit Output Signals Window

Six digital-to-analog (DAC) converters are available for output signals and they correspond with the rear panel Readout connectors J71 - J76.

Use this window to define output signals.

Controls are added to the bottom of the window according to the Signal Type you select.

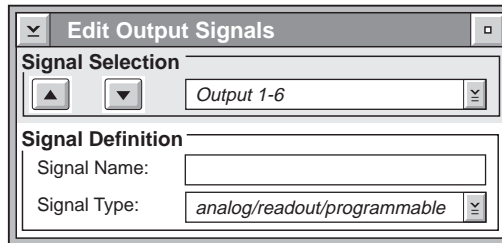

CONTROL	FUNCTION
Signal Selection	Selects one of the 6 possible output signals for definition.
Signal Name	Names the output signal. The name you enter is used throughout TestStar to identify this output signal. Enter any name you wish. The default name is the same as the Signal Selection name.
Signal Type	Specifies the type of signal you want to define. Your selection displays appropriate controls at the bottom of the window.
None	Disables the output.
Analog Bus	Use this selection to monitor analog signals during calibration and setup procedures. This selection is available only on Output 1 and Output 2.
Readout	Use this selection to monitor any sensor or valve signal. This type of output can be scaled.
Programmable	This selection customizes the output for use with optional applications. Your MTS TestWare application manual will tell you if you need a programmable output.

Signal selection

The output signals DAC 1 through DAC 6 correspond with the rear panel connectors J71 through J76.

All six output signals are also available at rear panel connectors J41A and J41B.

See the Installation manual, Chapter 3 for cable and signal information.

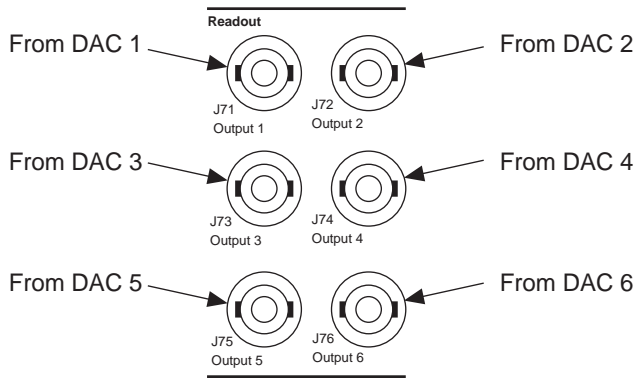



Analog Bus

Most of the signals in TestStar are converted to digital information for processing. Some signals are available before they are converted. The analog signals that are available are related to the plug-in modules. The analog bus is needed to monitor these signals.

A Device is one of the plug-in modules (an ac/dc conditioner or a valve driver). Each device has a unique set of signals you can monitor.

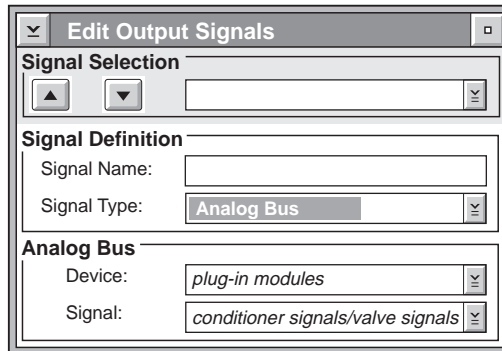

Using the output

Connect an analog readout device (such as a voltmeter or an oscilloscope) to the appropriate rear panel connector. Only Outputs 1 and 2 can be configured as analog outputs. Monitor the analog outputs as follows:

- ◆ Analog A = Output 1 = J71
- ◆ Analog B = Output 2 = J72

Valve signals

These signals are associated with the 490.14/.17 Valve Drive modules. They are available only when a valve signal is selected for the analog bus.

SIGNAL	DESCRIPTION
Valve Current A Valve Current B1	The current of the servovalve command signal.
Balance A Balance B1	The amount of offset introduced by the valve balance controls.
Spool Position2	The inner loop LVDT feedback signal.
Rate2	The amount of signal applied with the Rate adjustment.
Error2	The difference between the command and the feedback of the current control mode.

- 1 These signals are available only for dual 252 drives.
- 2 These signals are available from a Model 490.17 Valve Driver.

Sensor signals

These signals are associated with the 490.21/.22 DC/AC Conditioner modules. They are available only when a sensor signal is selected for the analog bus.

SIGNAL	DESCRIPTION
Transducer	The conditioned sensor feedback signal before it is converted into digital form.
Transducer Zero	The amount of offset introduced by the sensor zero adjustment.
Pre Amplifier	The sensor signal output from the preamplifier stage of the conditioner.
Positive Excitation Negative Excitation	The excitation signal output to the sensor is a differential signal. The actual excitation voltage is the difference between the positive and negative components of the signal.
Filter	The output of the 3-pole filter.
Summing Amplifier	The sensor feedback signal with Δk , zero, and the filter, but before gain is applied.
Raw AC Feedback	The 10 kHz feedback signal before it is demodulated. (Only available from the Model 490.22 AC Conditioner)



Readout

Use this window to select a signal and scale it for output.

CONTROL	FUNCTION
Signal	Selects one of the following signals to be assigned to the output: <ul style="list-style-type: none"> any input signal the valve command signal from any control channel the program command signal to the active control mode the error signal from the active control mode
Gain	Specifies a multiplier for the output signal. The Gain setting of 1 (default) scales the readout signal to 1 volt per unit. Use gain to customize the amplitude of the output signal for your needs.
Offset	Specifies a mean level offset of the output signal. The Offset setting of 0 (default) references the signal to 0 volts. Use offset to calibrate the TestStar output with your monitor device.

How it works

Note A monitoring device should be connected to the rear panel connector (J71 - J76) that corresponds with the DAC you defined

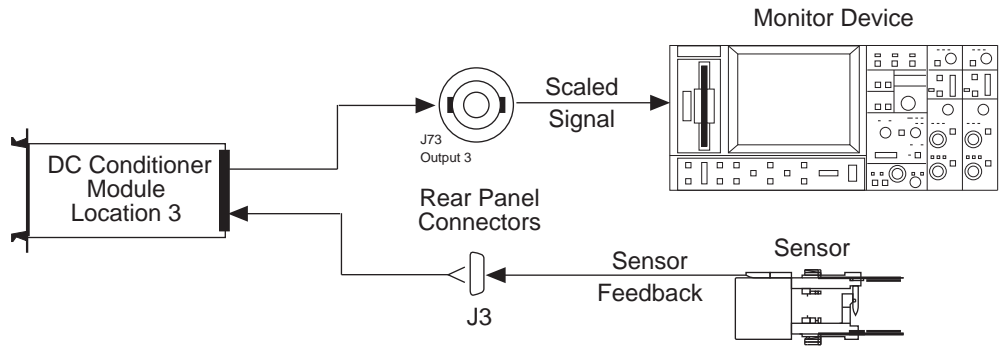

Gain calculation

Assume you use a ± 3 cm displacement sensor. A full-scale displacement sensor output of +3 cm would produce a readout signal of +3 volts (with the Gain set to 1).

Remember When gain is set to 1, then 1 unit = 1 volt.

To change the scale of the output use the formula:

$$\text{gain} = \frac{\text{desired output}}{\text{sensor output}}$$

Where:

- ◆ Gain is the value you enter into the Gain entry field.
- ◆ Desired output is expressed in volts (within 10 volts).
- ◆ Sensor is expressed in engineering units.

Therefore, changing the gain to 3.33 changes the displacement sensor output of +3 cm into a +10 volt readout signal.

Displacement gain example

Assume you create a test program that requires a 0-to-1 cm haversine command.

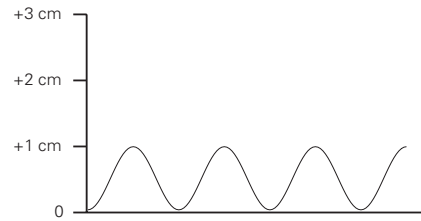

With the Gain set to 1, the output produces a 0-to-1 volt signal.

Changing the gain to 3.33 magnifies the output to produce a 0-to-3.33 volt signal.

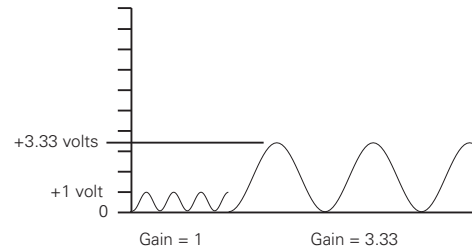

Force gain example

Assume you create a test program that requires a 0-to-11 kN haversine.

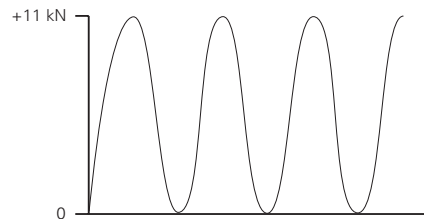

With the Gain set to 1, the output tries to produce a 0-to-11 volt signal. However, the maximum output is 10 volts, and the output clips 1 volt.

Changing the gain to 0.909 produces a 0-to-10 volt signal.

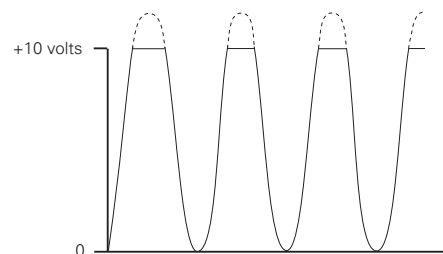

Offset example

Assume you create a test program that ramps to 11 kN and holds the force at that level.

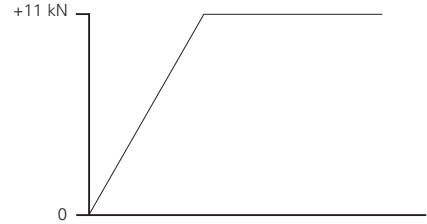

With the offset set to 0, the output tries to produce a 0-to-11 volt signal. However, the maximum output is 10 volts and the output clips 1 volt

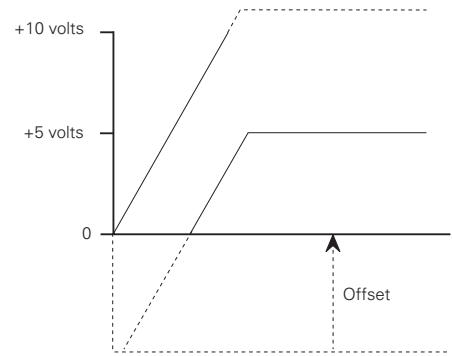

Changing the offset to 6 volts produces a 0-to-5 volt signal that represents the 6-to-11 kN portion of the waveform.

Offset and gain example

Assume you create a test program that ramps to 1.5 cm and cycles between 1.5 and 2 cm.

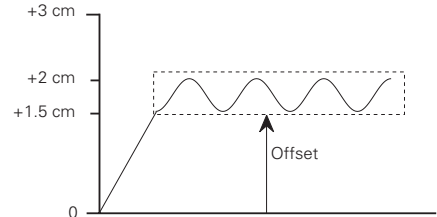

Assume you want to view the 0.5 cm haversine as a 5 volt readout signal. When gain is set to 1, then 0.5 cm equals 0.5 volt. (1 cm = 1 volt).

Setting the offset to 5 volts and the gain to 10 produces a 0-to-5 volt signal that represents the 1.5-to-2 cm haversine.

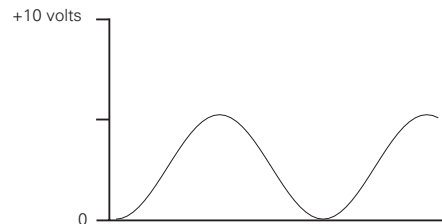



Programmable Output

This selection allows optional applications to customize the output.

The screenshot shows a dialog box titled "Edit Output Signals". It is divided into three sections:

- Signal Selection:** Contains two arrow buttons (up and down) and a text input field with an "OK" button to its right.
- Signal Definition:** Contains a "Signal Name:" label followed by a text input field, and a "Signal Type:" label followed by a dropdown menu currently showing "Programmable" and an "OK" button to its right.
- Programmable:** Contains a "Label:" label followed by a text input field with an "OK" button to its right.

When you select a programmable output, the rear panel connector is reserved for use by an optional TestWare application. Your MTS TestWare application manual will tell you if you need a programmable output.

For example, the 790.10 TestWare-SX application has an analog output process that uses a programmable output. This process causes the rear panel connector to output a specific voltage to control an external device.



Control Channels

A control channel commands an axis of movement (or some other operation such as pressure or temperature). TestStar supports up to four control channels. Each valve driver module represents a control channel. You need to know the following to define a control channel:

- ◆ Where is the servovalve connected to TestStar?
- ◆ What kind of drive signal is needed to control the servovalve?
- ◆ What type of compensator, if any, is needed for this channel?

After you define the control channels you will need to tune each control mode.

Servovalve connection

The maximum number of control channels is established during the TestStar software installation. Each control channel has a valve driver module plugged into the digital controller. Module locations 11 - 14 correspond with rear panel connectors J11 - J14.

The convention for multiple control channels is:

- Channel 1 = J14
- Channel 2 = J13
- Channel 3 = J12
- Channel 4 = J11.

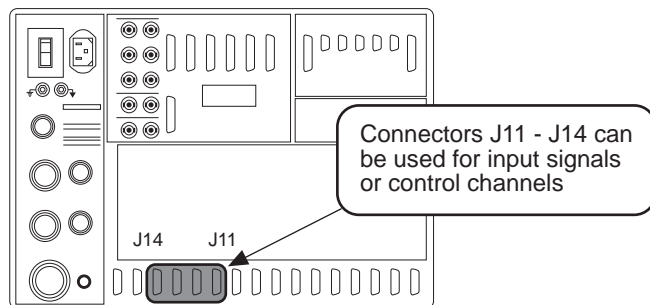

For multiple channel systems, you need to identify each actuator and determine the control channel (rear panel connector) that is associated with it. Knowing the nature of the control channel (axial, torsional, or pressure) helps you determine what kind of control modes you need to define.

Kinds of drives

A drive can be a servovalve or a servomotor. You need to determine what kind of drive is associated with the control channel you are going to define. The drive (servovalve or servomotor) type configures the Adjust Drive window with appropriate controls to adjust the drive signal.

Note *During the software installation, the system configuration is set for hydraulic or electromechanical. The system configuration determines what selections are available for the drive type.*

References to the term "servovalve" in this manual should be considered "servomotor" if your system configuration is set for electromechanical.

Compensators

Compensators are methods that ensure a programmed command is reached. While methods may vary, compensators monitor sensor feedback and adjust the command until the programmed level is achieved.

The peak/valley compensator (amplitude control) is always available to all control channels. The phase/amplitude (PAC) compensator must be enabled to become available. When it is enabled, system resources are allocated to the control channel. This means that the maximum servo loop update rate is reduced.

More information

Tuning	<i>Tuning</i> on page 259
Adjusting the valve	<i>Installation Manual (B)</i>
Defining control modes	<i>Control Modes</i> on page 116
Setting the number of control channels	<i>Installation Manual (A)</i>



Edit Control Channels Window

TestStar can control up to four control channels. A control channel commands one axis of movement. Each control channel uses a Model 490.14 or 490.17 Valve Driver module to produce a servovalve signal.

Prerequisite

The maximum number of control channels is chosen during the Hardware Configuration portion of the software installation procedure.

Use this window to define each control channel.

Each control channel requires a drive type and at least one control mode.

The screenshot shows the 'Edit Control Channels' window with the following configuration:

Control Channel Selection	
Control Channel 1	[OK]
Control Channel Definition	
Channel Name:	Control Channel 1 [OK]
Channel Type:	Controller [OK]
Channel Label:	Axial [OK]
Drive Type:	252 Valve [OK]
Auto Tuning Control Mode	Undefined [OK]
Phase/Amplitude (PAC)	Disabled [OK]

CONTROL	FUNCTION
Control Channels	Selects the control channel you want to define. The number of control channels is selected during the software installation.
Channel Name	Names the control channel. Type a name you wish to call the channel. This name is used throughout TestStar to identify the control channel. The default name is the same as the Control Channels selection.
Channel Type	Controller is the only type available. It represents a servo loop controller. Selecting none removes the control channel and any related control modes.
Channel Label	Labels the control channel as a particular type of channel <ul style="list-style-type: none"> • Axial • Torsional • Pressure • Generic
Drive Type	Specifies the type of servovalve connected to the control channel. <ul style="list-style-type: none"> • none • 252 • dual 252 • 256/257 <p>Selecting none will maintain the selections in this window but will not allocate controller resources to produce a signal.</p>
Auto-Tuning Control Mode	Selects a control mode to control the actuator while the auto-tuning feature monitors the response of the control mode being tuned. If no control modes have been tuned, select Undefined. Normally, a tuned displacement control mode should be selected.
Phase/Amplitude (PAC)	Enables or disables the phase and amplitude control compensation method. When enabled, PAC can be selected by any cyclic command used by the function generator or TestWare-SX process.

Control channel

When you define a control channel, you also define all the control modes available for that channel. Each control channel is associated with a module location in the digital controller.

A control channel can be assigned to one of the module locations 11 - 14. The following table shows the recommended assignments.

CONTROL CHANNEL	MODULE LOCATION
1	14
2	13
3	12
4	11

Each control channel uses a control mode to determine the required command.

Each control channel controls an axis of actuator movement by providing the valve drive signal to the servovalve.

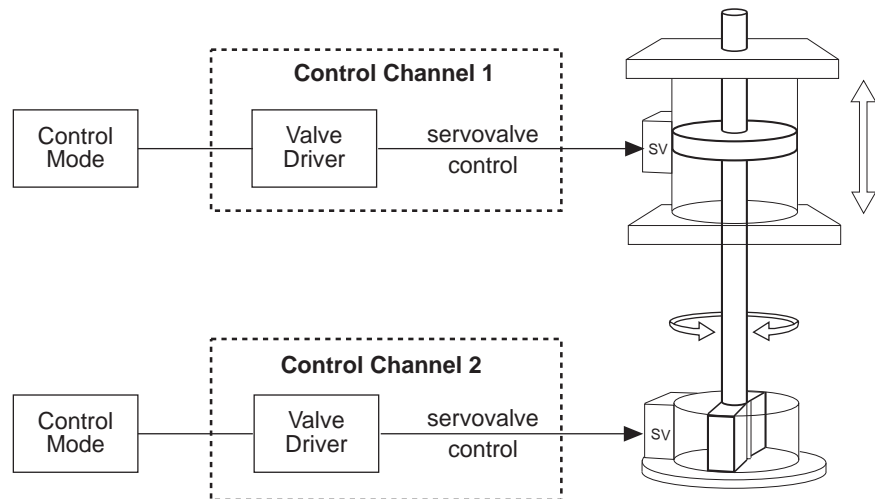

Drive type

Each control channel provides a drive signal to a servovalve. The valve type specification tells TestStar what kind of signal to output to the servovalve. You can determine which servovalve you have by checking the valve driver module located in the digital controller or by looking at the actuator manifold.

TestStar checks the module ID for the slot location that is associated with the control channel. The module ID (490.14 or 490.17) determines which Drive Type selections is available.

- ◆ A Model 490.14 Valve Driver supports 252 and dual 252 servovalves.
- ◆ A Model 490.17 Valve Driver supports 256 and 257 servovalves.

The valve type selection also configures the Adjust Drive window with appropriate controls for the valve.

Auto-tuning control mode

The auto-tuning control mode lists all of the control modes defined in TestStar. Not all of the control modes are valid selections. A valid control mode for auto-tuning must be able to run 100% full-scale. A valid auto-tuning control mode is usually a displacement or angular control mode.

Auto-tuning uses one control mode to control the servo loop while tuning another control mode. *For example*, tuning a force control mode needs a tuned displacement control mode as the auto-tuning control mode. This allows the system to reliably control the actuator using displacement while monitoring the force sensor. Monitoring the force sensor data allows the auto-tuning feature to calculate tuning values appropriate for the control mode.

The default selection Undefined should be used. TestStar automatically updates the undefined selection to the first auto-tuned control mode.

Phase and amplitude control

The patented PAC (phase & amplitude control) method compensates for amplitude error and phase lag. Amplitude error refers to the tendency of amplitudes measured by the sensors to be less than the desired amplitudes. Phase lag refers to the tendency of the feedback signal to trail the command signal at higher frequencies.



Control Modes

Each control channel requires at least one control mode. Each control mode uses at least one input signal. Knowing the nature of your test program and the type of control channel helps you determine what kinds of control modes (and their types) are needed. Up to ten control modes can be defined for each control channel.

For example, an axial control channel has control mode that controls length. The equivalent control mode for a torsional control channel is rotation.

Control mode types

A control mode links the feedback from a sensor (input signal) with a program command to control the servovalve. TestStar uses the following control modes:

PIDF ♦ Represents four gain adjustments (proportional, integral, derivative, and feed forward). This is the most widely used control mode for a closed loop system. See [PIDF Control Mode](#) on page 118

Channel Limited Channel ♦ CLC represents a control mode that uses a master input signal to control the actuator while a second input signal limits the master control. This control mode is primarily used for specimen installation. See [Channel Limited Channel Control Mode](#) on page 120.

Cascade ♦ CASC represents a cascade control mode that uses two control loops. The output of the outer control is the input to the inner control loop. This control mode is primarily used for dynamic testing with force control. See [Cascade Control Mode](#) on page 121.

Prerequisite

You must define the input signals and the control channels before defining any control modes.



Edit Control Modes Window

Use this window to define the control modes for each control channel.

PARAMETER	FUNCTION
Control Channel	Selects the control channel for the control mode that is created with this window.
Control Mode	Selects one of the 10 control modes you can define.
Mode Name	Names the control mode. Type a name you want to call the control mode. This name is used throughout TestStar to identify the control mode.
Mode Type	<p>Specifies the type of control mode you want to define. Your selection displays appropriate controls at the bottom of the window that define the control mode.</p> <ul style="list-style-type: none"> • PIDF provides the highest level of servo loop response and is used primarily for specimen testing and can be used for specimen installation. • Channel Limited Channel (CLC) is a special control mode used for specimen installation. • Cascade (CASC) provides a high degree of stability and is primarily used for dynamic testing with force control.
Mode Label	Selects a letter to distinguish control modes of the same dimension.

PIDF Control Mode

A PIDF control mode type has several gain adjustments to stabilize the servo control loop. PIDF represents proportional, integral, derivative, and feed forward gain adjustments. These adjustments are also called gain, reset, rate, and feed forward respectively.

Selecting the PIDF Mode Type displays this window configuration.

The screenshot shows the 'Edit Control Modes' window with the following configuration:

- Control Channel Selection:** A dropdown menu with up and down arrow buttons and a 'OK' button.
- Control Mode Selection:** A dropdown menu with up and down arrow buttons and a 'OK' button.
- Control Mode Definition:**
 - Mode Name: A text input field.
 - Mode Type: A dropdown menu with 'PIDF' selected and a 'OK' button.
 - Mode Label: A text input field with a 'OK' button.
- PIDF Mode Definition:**
 - Command Source: A dropdown menu with 'segment generator/pod/external' selected and a 'OK' button.
 - Feedback: A text input field with a 'OK' button.
 - External Source: A text input field with 'slot 7 - 14' and a 'OK' button.

PARAMETER	FUNCTION
Command Source	Selects the source of the command signal. The selections are: <ul style="list-style-type: none"> • Segment Generator • Pod • External
Feedback	Selects an input signal as the source of feedback for the control mode.
External Source	Specifies the location of the external command source (if external is the selected command source).

Command source

The command for a PIDF control mode can come from one of three sources.

Segment generator

The source is from TestStar Function Generator or TestWare application.

Pod

The command source is from the Actuator Positioning Control (APC) on the load unit control panel.

External

The command source is from an external device connected to the rear panel of the digital controller. This selection is available only if you select a feedback (input signal) that is defined as an external signal type.

Note See Chapter 10 in the Installation manual if you are using an external command source or an external feedback signal.



Channel Limited Channel Control Mode

A CLC control mode uses one input channel to control the servo loop (feedback) while using a second input channel (limiting channel) to restrict the command source.

The limiting channel uses a limit range to ensure the feedback signal cannot produce a command that exceeds the range set for the limiting channel.

Selecting the Channel Limited Channel Mode Type displays this window configuration.

The screenshot shows the 'Edit Control Modes' window with the following configuration:

- Control Channel Selection:** A dropdown menu with an empty selection and a 'OK' button.
- Control Mode Selection:** A dropdown menu with an empty selection and a 'OK' button.
- Control Mode Definition:**
 - Mode Name: An empty text field.
 - Mode Type: A dropdown menu with 'Channel Limited Channel' selected and a 'OK' button.
 - Mode Label: An empty text field with a 'OK' button.
- CLC Mode Definition:**
 - Command Source: A dropdown menu with 'Pod' selected and a 'OK' button.
 - Feedback: An empty text field with a 'OK' button.
 - Limit Channel: An empty text field with a 'OK' button.

CONTROL

FUNCTION

Command Source

The only command source available is **Pod**. This command source is from the Actuator Positioning Control (APC) on the load unit control panel.

Feedback

Selects an input signal as the source of feedback for the control mode.

Limit Signal

Selects an input signal as the source of feedback for the limiting channel.



Cascade Control Mode

The Cascaded control mode is used for specimen testing that requires a high degree of stability (such as dynamic load applications). Use the cascaded control mode for special dynamic testing.

Selecting the CASC Mode Type displays this window configuration.

CONTROL	FUNCTION
Command Source	The source of the command signal can only be from a segment generator. A segment generator can be the TestStar Function Generator or TestWare application.
Outer Loop	Selects an input signal as the source of feedback for the outer loop of the control mode.
Inner Loop	Selects an input signal as the source of feedback for the inner loop of the control mode.



Calculation Constants

Calculation constants are used in calculated input signals. Calculation constants are helpful when you use a constant in more than one calculation. This way, the constant can be changed with this window instead of changing each formula that uses a specific constant.

Use this window to assign a name and a value to a constant.

Use the name of the constant in the formula that defines a calculated input.

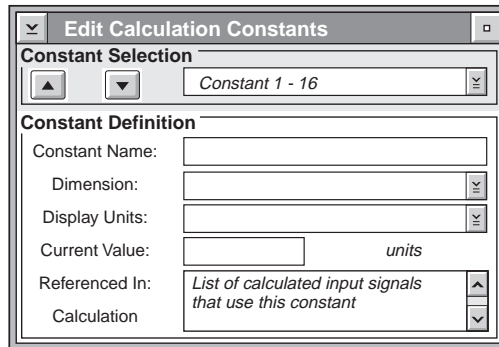

CONTROL	FUNCTION
Constant Selection	Selects a constant to define. You can define up to 16 constants.
Constant Name	Names the constant. Type a name you wish to call the constant. Use this name in the formula that defines a calculated input signal. The default name is the same as the Constant Selection.
Dimension	Assigns the type of units for this constant. Select a dimension that is appropriate for the constant.
Display Units	Selects the specific units you wish to assign to the constant. The selected dimension determines what units are available.
Current Value	Specifies the value of the constant.
Referenced in Calculations	Lists all the calculated input signals that use this constant. This helps you determine the impact of changing the value of the constant.

Examples

The following constants are referenced in the Calculated Input Signal description.

Constant Name:	Pi	radius	Modulus
Dimension	Unitless	Length	Pressure
Display Units	(none)	mm	MPa
Current Value	3.14	12.5	10
Referenced In Calculations	Area Axial Stress	Area Axial Stress	Corrected Axial Strain

The following shows how a calculated input signal could also be used as a calculation constant:

Area

This example calculates the area of a cross section of a specimen. The constant “Area” (the calculated input below) may be referenced by other calculated inputs even though it is not defined with the Calculation Constants window. However, its components are calculation constants.

$$=\{\text{Pi}\} * \text{power} (\{\text{radius}\}, 2)$$

Where:

Pi is a calculation constant.

radius is a calculation constant that represents half the diameter of the specimen cross section.



Detector Actions

A detector action is an event that occurs when conditions of a detector are true. This is also called a detector fault.

- ◆ Four standard actions are always available.
 - ◆ You can define up to six hold or ramp/hold actions.
 - ◆ The detector actions are available for all TestStar detectors.
-

Defining actions

You need to know the following before you define an action.

- ◆ How do you want the actuator to be controlled when a detector action occurs?
 - ◆ What control mode is the best to prevent specimen damage or control actuator movement when a detector action occurs?
 - ◆ *For example*, if the specimen breaks and force control is used, the actuator continues to move until the required force is detected (this could cause damage). But a length control mode can still ramp or hold the actuator when the specimen is broken.
 - ◆ What command (ramp or hold) is best for each detector?
-

Standard actions

The following are the four standard actions available for every detector.

- ◆ **Disabled** – turns the detector off.
 - ◆ **Indicate** – displays a message in the Fault Status window that the detector has been triggered.
 - ◆ **Hydraulics Off** – turns off the hydraulic pressure at the service manifold, displays a message in the Fault Status window and lights the Aux indicator on the LUCP.
 - ◆ **Interlock** – turns off the hydraulic pressure, generates an interlock signal, clamps the servovalve, and displays a message in the Fault Status window. You must correct the reason for the interlock and use the Reset button (located on the load unit control panel) to clear the interlock.
-

Fault status window

The source of a detector action is identified by the name of the input signal or control channel as defined by the Edit Input Signals window or Edit Control Channels window. The type of detector is also shown.

All detector actions that occur are reported in this window.

The window remains on-screen until the detector condition(s) is resolved.

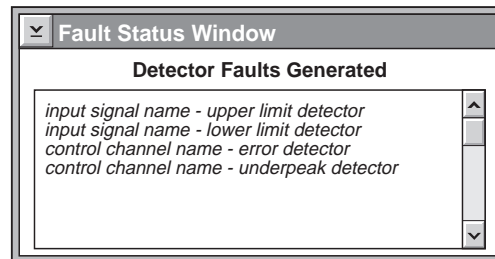

More than one detector action may occur. Sometimes the first detector fault causes other faults to occur. Refer to Chapter 1 for instructions on how to reset interlocks or correct faults.

More information

Setting limits	Upper and lower limits on page 151 Display Detector Actions on page 193)
Setting the error detector	Error Detectors on page 174
Setting the underpeak detector	Underpeak Detectors on page 177
Changing detector actions	Display Detector Actions on page 193



Edit Detector Actions Window

Customer-defined actions stop the test program and holds the output of any control mode. A ramp and hold operation is also available. The detector actions are available to all TestStar detectors

- ◆ Error detectors
- ◆ Underpeak detectors
- ◆ Limit detectors.

Use this window to define up to 6 customer-defined detector actions.

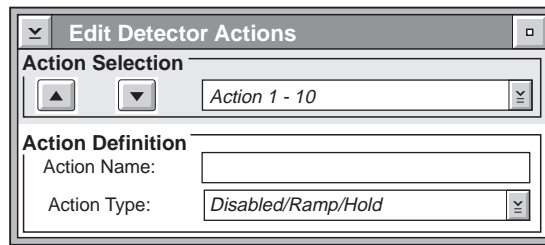

CONTROL	FUNCTION
Action Selection	Selects an action to define. Actions 1 - 4 are predefined and cannot be changed. Only actions 5 - 10 can be defined.
Action Name	Names the detector action. The name you enter is used throughout TestStar to identify this action.
Action type	Specifies a ramp or a hold action. Controls needed for the selection are added at the bottom of the window. The Disabled selection closes the action so it does not appear in the detector action selections.

Standard actions

The first four actions cannot be changed and are identified as follows:

- ◆ Action 1 Disabled
- ◆ Action 2 Indicate
- ◆ Action 3 Hydraulic Off
- ◆ Action 4 Interlock



Hold Actions

Hold actions are useful when you want to stop a test without causing an interlock or tuning the hydraulic pressure off.

Selecting the Hold action type displays this window configuration.

Using hold actions

All that is needed is to select a control channel and a control mode. The type of control mode should reflect how the action will be used.

For example, a general purpose hold action uses a length control mode. When a fault is detected the actuator holds its current position. If a limit detector faults because the specimen breaks, this action can prevent damage to other equipment.

Another example, assume you want to stop the test to change test parameters when force reaches a specific level. In this case a hold action in force control would allow you to stop the test, change parameters (including the detector that stopped the test) and resume the test.

For Biaxial, you need to perform these steps:

1. Select your control channel.
2. Select your control mode.
3. Perform the Step 2 for each control channel.



Ramp Actions

Selecting the Ramp action type displays this window configuration.

Ramp actions are useful when you want to move the actuator using any control mode and stop a test without causing an interlock or tuning the hydraulic pressure off.

CONTROL	FUNCTION
Ramp Time	Sets the amount of time (in seconds) for the ramp. The selected control mode ramps from the current level to the specified end level in the specified time.
Control Channel	Selects a control channel defined with the Edit Control Channels window.
Control Mode	Selects a control mode defined with the Edit Control Channels window.
End level	Sets the end level for the ramp. The units of the control mode are assumed.

Using ramp actions

You really need to know how the test behaves when using a ramp action. *Be sure* to set up a detector appropriate for your test.

For example, assume the test is designed to break the specimen and a detector is set to sense the break. A ramp could be designed to move the actuator back to a specimen installation position for the next test.

However, if the detector activates before the specimen breaks, the system would stop the test program and ramp the actuator to a predefined position. This could pull the specimen apart or possibly damage equipment.



Load Path Stiffness

The load path stiffness set compensates for the amount of deflection in the load path. This includes the grips, extensions, load cell, and load frame. All of these components act together (along with the specimen) as the load path.

Note *Load path stiffness sets are created with the Load Path Stiffness Editor. The Load Path Stiffness Editor is described in Appendix F.*

Load path stiffness is only needed when running any 790.3x TestWare processes.

How it works

The load path stiffness parameters compensate for the amount of deflection that is produced from the actuator, through the grips, extension rods, load cell, and load frame (everything in the load path except the specimen). All of these components act together as the load path.

The load path stiffness editor defines a set of stiffness values for the displacement sensors and saves it in a data base. A stiffness set consists of stiffness values for an LVDT, accelerometer and in some cases, an ATD. Any unique combination of the components of the load path should have a stiffness set defined for them.

For example, assume you have a system that uses compression platens with extension rods (to accommodate a temperature chamber) for one type of test. For another type of test you use the compression platens without the extension rods. You should create a stiffness set for both types of tests.



Edit Load Path Stiffness Window

Use a load path stiffness set to remove any influence the load path hardware components have on the specimen displacement data.

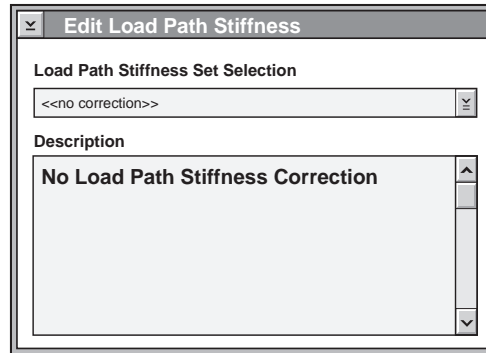

Using the window

Use the list icon to select a predefined load path stiffness set. The description of the load unit stiffness set is also shown. A load path stiffness set should be created for any combination for load path components.

For example, assume you change your test to one that requires a different set of grips. You should have a load path stiffness set for both configurations of the load path.

Use the Refresh button to update the list of load unit stiffness sets if a new one is created while TestStar is running or an existing set is modified. TestStar only checks the list of stiffness sets when it is started.





LUCP Display

Use this window to define the appearance of the display on the load unit control panel.

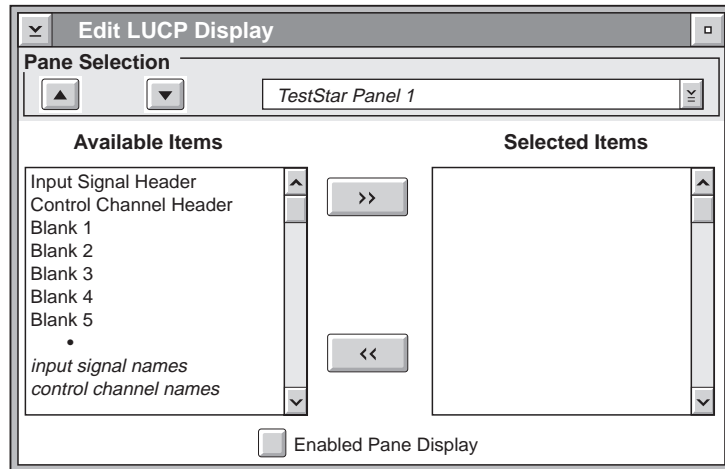
The first seven items are available for each LUCP window.



CONTROL	FUNCTION
Pane Selection	Selects one of the display panes available for the load unit control panel.
Available Items	Lists the items that can be displayed in the load unit control panel display. All input signals and control channels are available for display (along with a selection of standard items).
Selected Items	Lists the item in order as they would appear in the load unit control panel display.
	Moves highlighted items from the Available Items column to the Selected Items column.
	Moves highlighted items from the Selected Items column back to the Available Items column.
Enabled Pane Display	Check this box to display this pane on the load unit control panel. The pane cannot be seen unless it is enabled.

Standard items

The following items are standard in the LUCP Display window:

- ◆ The Input Signal Header displays “Sensors” and “Current Value” above a list of input signals.
- ◆ The Control Channel Header displays “Controllers,” “Current Mode,” and “LUCP Mode” above a list of control channels.
- ◆ Five blank lines can be used to separate items in the LUCP display.

Using the window

Select items one at a time in the Available Items column and use the right arrow button to move it to the Selected Items column. More than one item can be selected and moved at a time.

The order of items in the Selected Items column represents the order in which they will be seen in the load unit control panel display.



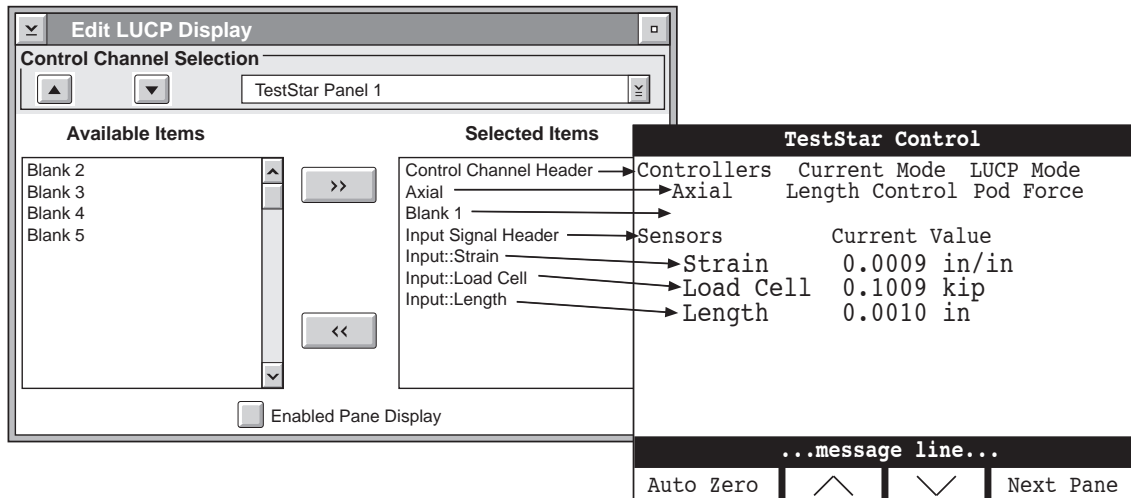

























Items in the Selected Items column can be returned to the Available Items column by selecting them and pressing the left arrow button.



The load unit control panel display can accommodate 16 rows (including the title bar, message bar, and switch descriptions). Each row can have up to 40 characters. Use the F4 switch to toggle between TestStar Panel 1 and TestStar Panel 2.

Toolbar

The toolbar is a row of buttons displayed below the menu bar. These buttons that can open any TestStar windows.

	Open Configuration File		Edit Scope
	Save Configuration File		Adjust Input Signals
	Select Font		Adjust Tuning
	Print Preview		Adjust Compensators
	Edit Input Signals		Adjust Error Detectors
	Edit Output Signals		Adjust Underpeak Detectors
	Edit Control Channels		Adjust Servovalve
	Edit Control Modes		Display Input Signals
	Edit Calculation Constants		Display Detector Actions
	Edit Detector Actions		Display Meters
	Edit Load Path Stiffness		Display Scope
	Edit LUCP Display		Servo Loop Update Rate
	Edit Toolbar		Fault Status
	Edit Meters		Debug





Configure Toolbar Window

Configure your toolbar with buttons that represent the windows you open most often.

Note We recommend that you do not configure the toolbar until you are familiar with TestStar. Use TestStar until you establish your working habits, then you will know which windows you want to access quickly.

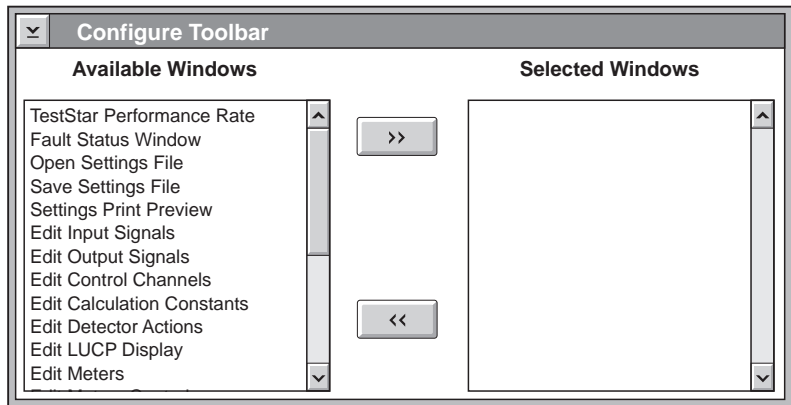
Use this window to define the toolbar in the main TestStar window.



CONTROL	FUNCTION
Available Windows	Lists all the TestStar windows. Select each window you want to assign to the toolbar.
Selected Windows	Lists the window in order as they would appear in the toolbar.
	Moves highlighted items from the Available Windows column to the Selected Windows column.
	Moves highlighted items from the Selected Windows column back to the Available Windows column.

Using the window

Select windows one at a time in the Available Windows column and use the right arrow button to move it to the Selected Windows column. More than one item can be selected and moved at a time.

The order of items in the Selected Windows column represents the order that they will be seen in the toolbar (from left to right).

Items in the Selected Windows column can be returned to the Available Windows column by selecting them and pressing the left arrow button.

The toolbar can have any combination of the window buttons.

In this case, the standard configuration is shown.

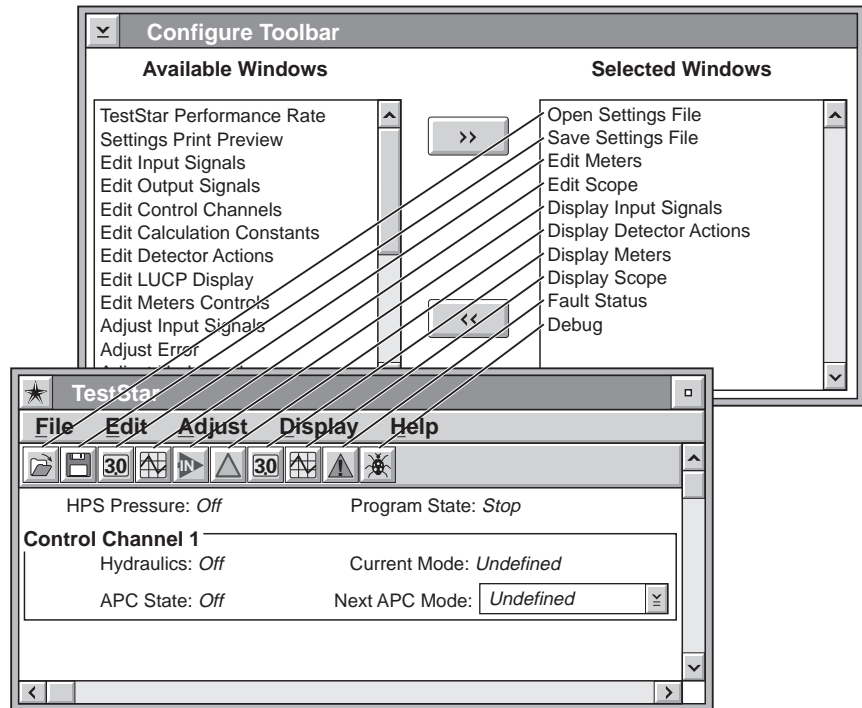



Meters

Define up to four meters.

A meter must be enabled to display it from the Display menu.

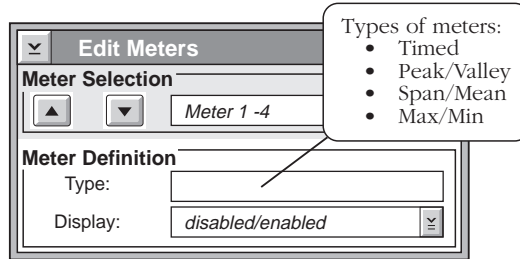

Types of meters

This waveform shows the type of data that can be displayed.

The peak/valley and span/mean modes update data each cycle.

The max/min (maximum and minimum) data mode monitors the entire waveform.

The timed data mode displays a signal value every second.

Each type of meter defines what information is displayed for a given input signal.

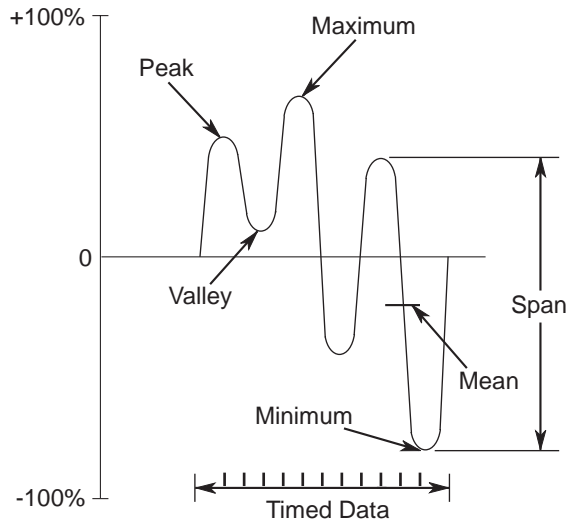



Meter Definition Window

Prerequisite You must have input signals defined before you can define a meter.

Use this window to define a data display.

Each Type selection adds appropriate controls to the bottom of the window.

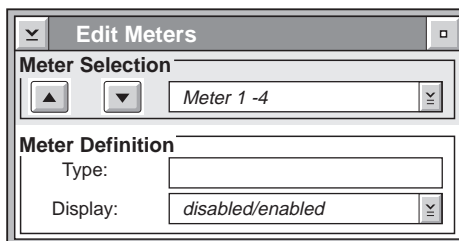

CONTROL	FUNCTION
Meter Selection	Selects one of the four meters you want to define.
Type	Selects the type of data you want to display. The selections are: <ul style="list-style-type: none"> ◆ Timed ◆ Peak/Valley ◆ Span/Mean ◆ Running Max/Min
Display	Enables or disabled the meter. When enabled the meter can be displayed from the Display menu .



Timed Data

Select two input signals.
The display will not display
a single signal.

Updates the display *once a second* with the amplitude of two input signals.

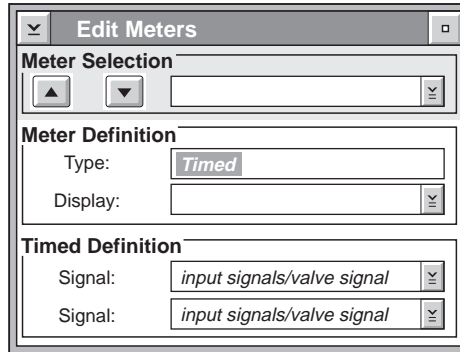

- ◆ All defined input signals are available for display.
- ◆ If a control mode is defined, the valve signal is also available for display.
- ◆ The display updates each signal once a second.

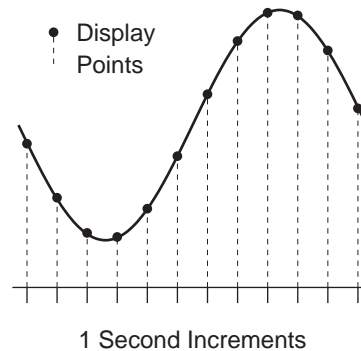



Peak/Valley Data

Use this window to select the sensor signal you want monitor peaks and valleys.

Set the sensitivity.

A peak/valley meter displays the highest and lowest values of an input signal during *each cycle* of a dynamic test.

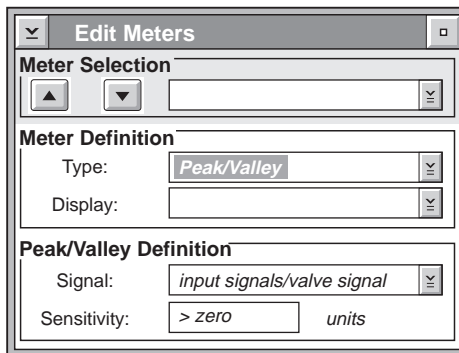

- ◆ The peak is the most positive (least negative) level.
- ◆ The valley is the most negative (least positive) level.
- ◆ The sensitivity setting is the amount the signal must change to detect a peak or valley.
- ◆ Setting the Sensitivity too high may cause low-amplitude signal changes to be missed.
- ◆ Setting the Sensitivity too low may cause signal noise to be recognized as a peak/valley value.

This waveform shows the peak and valley for each cycle.

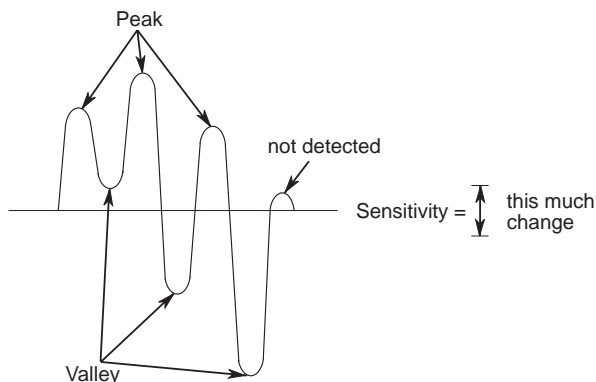



Span/Mean Data

Select an input signal that you want monitor span and mean levels.

Select the units for the data and set the sensitivity.

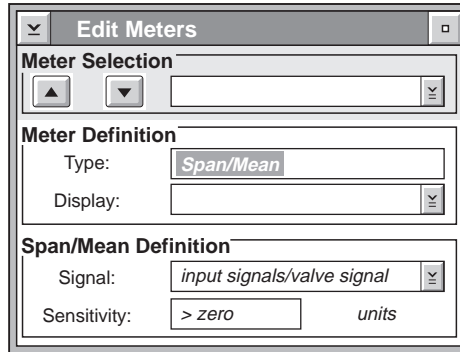

- ◆ The span value is the peak-to-valley amplitude of a cycle.
- ◆ The mean level is the midpoint of a cycle
- ◆ The sensitivity setting is the amount the signal must change to detect a peak or valley.
- ◆ Setting the Sensitivity too high may cause low-amplitude signal changes to be missed.
- ◆ Setting the Sensitivity too low may cause signal noise to be recognized as a peak/valley value.

This waveform shows the span and mean of each cycle.

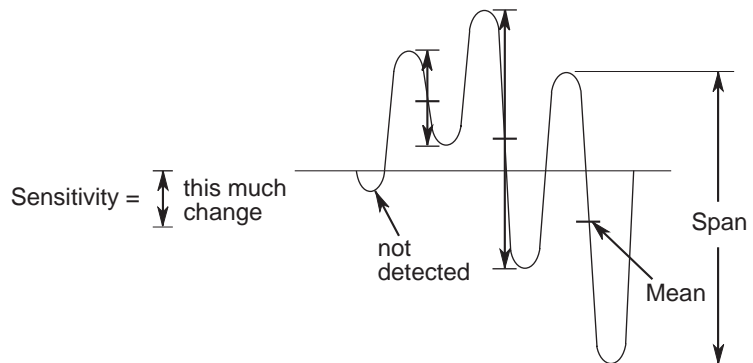



Max/Min Data

Displays the highest and lowest values of an input signal recorded during a test (or since the Data Display was reset).

Select an input signal that you want monitor max and min levels.

Select the units for the data.

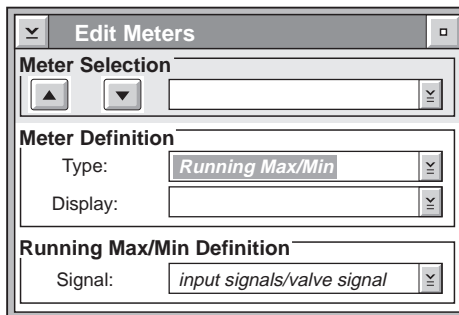

- ◆ The max value is the most positive (least negative) level.
- ◆ The min value is the most negative (least positive) level.

This waveform shows the initial maximum and minimum detections along with the maximum and minimum points.

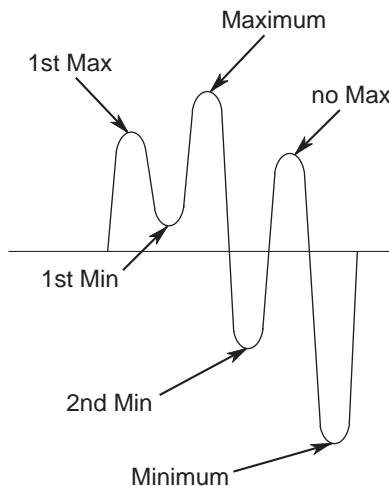



Scope

A scope is a graphical display on the computer screen that shows test related signals in a fashion similar to an oscilloscope.

Note *The scope requires processing time when it is enabled; this affects the communications with the digital controller and slows the data exchange rate between the digital controller and the computer.*

Use this window to define a digital scope to display a waveform.

The scope can display a graphic representation of up to two input signals.

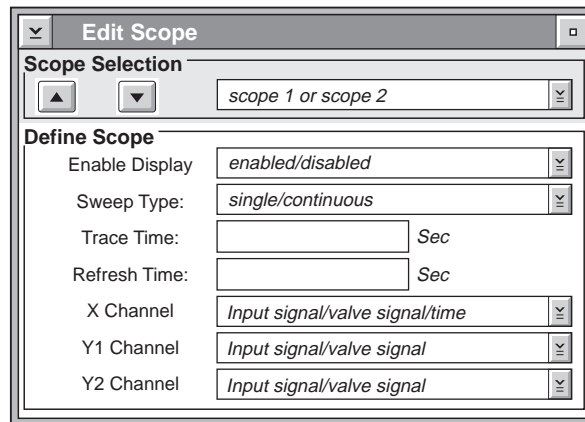

CONTROL	FUNCTION
Scope Selection	Selects one of the two scopes to be configured.
Enable Display	Enables or disables the scope. The scope must be enabled to display it. Disable the scope when it is not needed or if you wish to configure it and use it later.
Sweep Type	Selects a single sweep of the screen or continuous sweeps. A single sweep draws a signal on the screen once. A continuous sweep draws over the old signal trace with new data.
Trace Time	Specifies the amount of time for a trace to cross the scope. One hour is the maximum trace time.
Refresh Time	Specifies how often the data being drawn on the screen is updated. Shorter refresh times require more processing time (this reduces the computer processing time).
X Channel Y1 Channel Y2 Channel	Selects an input signal (or time) for the Y1, Y2, or X channel. The X channel is usually set for time. The X channel axis is the bottom of the screen. The Y1 channel axis is the left side of the screen. The Y2 channel axis is the right side of the screen.

Defining a scope

The **Sweep Type**, **Refresh Time**, and **Trace Time** controls work together to configure the scope for any kind of signal.

Note *The shorter the trace time and the longer the refresh time, the better the resolution of the waveform (more data points defining a waveform).*

For example, assume you want to watch a 90 minute ramp. Set up the scope with a single sweep type and a 90 minute trace time. This lets you see the entire waveform. Set the refresh time of 5 minutes.

Another example, assume you want to monitor a 2 Hz cyclic waveform. Set up the scope with a continuous sweep type and a 0.5 second trace time. This lets you see a single cycle. Set the refresh time to 10 seconds.

Channel selection

You must define at least one **Y Channel** and the **X Channel** to obtain a display. The X channel is usually defined as time. You can define X as an input channel to obtain a Lissajous waveform. When you want to use both Y axes, the X axis must be set for time.

Scope



TestStarTM II

Control System

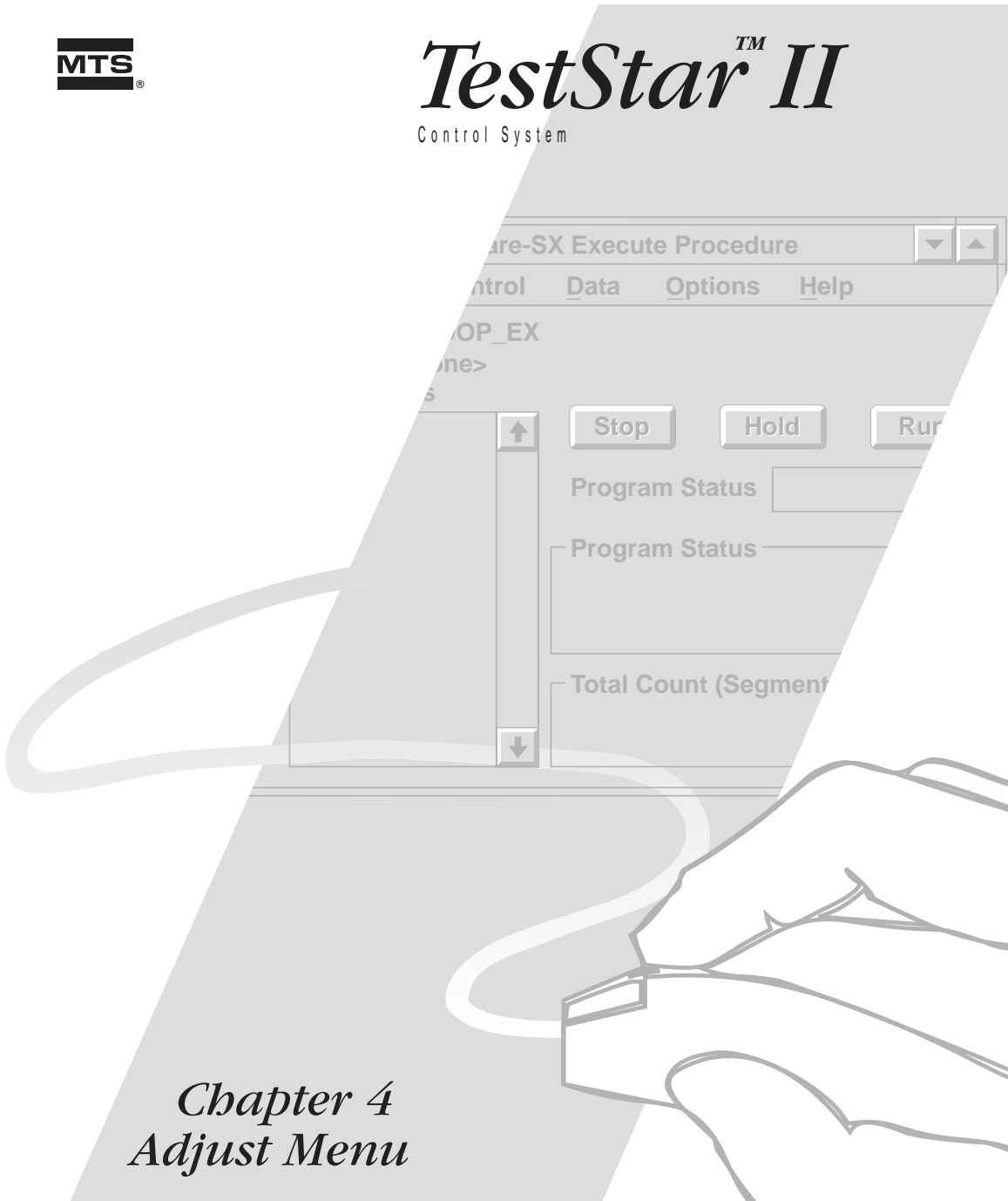

Chapter 4 Adjust Menu

Adjust Input Signals

Signal Selection:

Limits

Upper Limit: Action:

Lower Limit: Action:

Sensor Zero

Unlock Lock

Offset:

Auto Zero

Shunt Calibration

+ -

Sensor

Output:

Range:

Some of the controls in the lower half of this window are not available for some types of input signals.

Adjust Tuning

Control Channel Selection:

Control Mode Selection:

Appropriate tuning controls are added to the bottom of the window according to the type of control mode (PIDF, CLC, or CASC).

TestStar

File Edit Adjust Display Help

HPS Pressu
Control Chann
Hydraul
APC Sta

Input Signals
Tuning
Compensators
Error Detectors
Underpeak Detectors
Drive

Adjust Compensators

Control Channel Selection:

Convergence Rate:

Compensator Selection:

Compensator Adjustments

Limit:

Adjust Error Detectors

Control Channel Selection:

Error Actions

Maximum Action:

Minimum Action:

Control Mode Selection:

Error Detector Values

Maximum:

Minimum:

Adjust Drive

Control Channel Selection:

Valve Adjustments

Valve Balance A: Dither Amplitude:

Dither Frequency:

Spool Zero:

The Drive window you will see depends on your Drive Type selection in the Edit Controls Channel window.

Adjust Drive

Control Channel Selection:

Valve Adjustments

Valve Balance: AC Gain:

Dither Amplitude: Rate Gain:

Dither Frequency: Inner Loop Gain:

Spool Zero: Inner LoopPhase:

Setup

Adjust Underpeak Detectors

Control Channel Selection:

Underpeak Detector Values

Input Signal:

Action:

Maximum:

Minimum:

Sensitivity:

Chapter 4

Adjust Menu

Contents	Input Signals	148
	Adjust Input Signals Window	149
	Set Zero Scroll Range Window	156
	Shunt Cal Window	157
	Tuning	159
	Tune PIDF Window	161
	Auto Tuning	163
	Tune CLC Window	164
	Tune CASC Window	167
	Set Scroll Range Window	169
	Adjust Compensators	170
	Error Detectors	174
	Underpeak Detectors	177
	Adjust Drive	180
	Adjusting 252 and Dual 252 Valves	181
	Adjusting 256 and 257 Valves	184

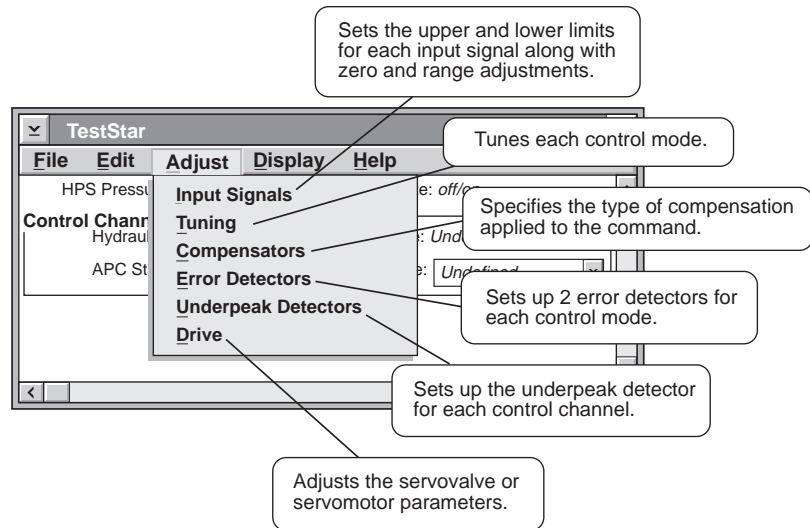



Input Signals

Each defined input signal can be adjusted to meet the needs of your test. Each input signal can be set up with the following:

- ◆ Sensor **limits** allow you to detect undesirable conditions (such as a broken specimen) or to detect significant points in a test (such as a transition in the test where the specimen characteristics change).
- ◆ **Sensor zero** allows you to remove any offset to the input signal that can be caused by specimen installation or the installation of test fixtures. The auto zero feature can be locked out.
- ◆ **Shunt calibration** allows you to check the accuracy of the input signal (sensor) and a conditioning module to a calibrated reference.
- ◆ **Sensor range** scales the input signal to a level that is appropriate for the test.

What you need to know

Before you can adjust the input signals you need to know the nature of the test. When you know what the test is designed to do you can determine the following:

- ◆ What is the expected output for each sensor?
- ◆ What is the appropriate range for each sensor?

If you do not know the expected sensor output, select the highest sensor range, or set the limit detectors to a level 1% to 10% below the range of the sensor, and select an action that stops the test.

Note *We recommend that you establish limits for at least one input signal. This can prevent damage to the test equipment if the servo control loop is broken (such as a cable becomes unplugged or the specimen breaks). The best input signal for this purpose is from the LVDT sensor.*

More information

Defining input signals [Edit Input Signals Window](#) on page 88
 Setting the shunt cal reference [Installation \(8,9\)](#)



Adjust Input Signals Window

Use this window to adjust each input signal. The window configures itself with appropriate controls for the selected input signal.

Prerequisites

You must define an input signal with the Edit Input Signals window before you can use this window.

This window shows all possible features.

The Sensor Zero, Shunt Calibration, and Acceleration Compensation features are present only for input signals that need them.

Adjust Input Signals

Signal Selection

Limits

Upper Limit units Action

Lower Limit units Action

Sensor Zero
 Unlock Lock
 Offset %

Shunt Calibration
 + -

Sensor
 Output: units
 Range:

Acceleration Compensation
 Compensation
 Polarity Normal Inverted

CONTROL	FUNCTION
Signal Selection	Selects the input signal you want to adjust. Each input signal can have a different set of parameters.
Limits	Establishes the settings of the limit detector for the selected sensor. If the sensor signal exceeds a limit, the selected action occurs.
Upper Limit	The upper and lower limits define an acceptable range for the sensor output during a test. The range of adjustment is within \pm full-scale of the selected input signal.
Lower Limit	
Action	Selects the action you want to occur when a limit is detected. Each limit can be assigned a different action.
Sensor Zero	Introduces an offset to zero the sensor's output. The offset is shown as a percentage of the sensor's output. Select Unlock or Lock to enable or disable the sensor zero feature in this window and the Display Sensor window.
Offset	This is not available for calibrated and external input signals. Opens the Set Scroll Range window to scale the adjustment range of the scroll bar
Auto Zero	Automatically zeros the sensor output.
Shunt Calibration	Performs a positive or negative shunt calibration check and displays the result in a Shunt Cal window This is available only for internal dc type sensors.
Sensor	Displays the current sensor output and allows you to change the range of the sensor. This is not available for calculated input signals.
Acceleration Compensation	Adjusts the amount of acceleration compensation that is applied to the input signal. This is available only for input signals that have an acceleration compensation circuit.
Polarity >>	Displays a polarity group where you assign the polarity of the acceleration compensation signal.

Upper and lower limits

The upper limit defines the most positive or least negative level for the limit detector. The lower limit defines the least positive or most negative level of the limit detector. The difference between the upper and lower limits represents the normal operating range of the sensor.

When set correctly, a sensor output beyond this range represents a change in the test that deserves attention. Limits can also protect your equipment if a specimen breaks. If the sensor output exceeds either limit, the digital controller performs the action that you assign with the limit action fields.

If the sensor output exceeds a limit, and if the selected action is Hydraulics Off, the test stops and hydraulic pressure is turned off.

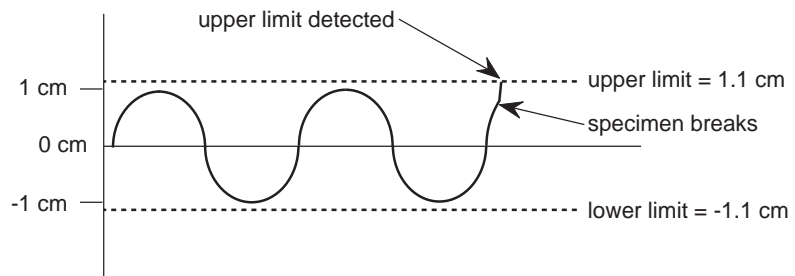

Setting

Set the limits to establish a normal operating range for the sensor during a test, then select an action you want performed if a limit is detected.

For example, assume you are testing a specimen using a displacement control mode. Also assume the LVDT has a displacement of 5 mm and you design the test to operate over the range of ± 2 mm. Setting the limits for either the displacement signal at -2.1 mm and $+2.1$ mm should protect the specimen from damage.

Unknown limits

If you do not know what the limit setting should be for a test, you will need to run the test and monitor the sensor signal. Set up a peak/valley or a max./min. meter to determine the maximum and minimum sensor values. While running the test, note the upper and lower values. Valid limits can be more than the upper value and less than the lower value.

Note We recommend that you establish limits for at least one input signal to prevent damage to the test equipment if the servo control loop is broken (such as a cable becomes unplugged or the specimen breaks). The best input signal for this purpose is from the LVDT sensor.

Actions

An action determines what happens when the associated limit level is crossed. Refer to Chapter 1 for instructions on how to reset action. The following are the actions you can use:

- ◆ **Disabled** – turns the limit detector off.
- ◆ **Indicate** – displays a message in the Fault Status window that the detector has been triggered.
- ◆ **Hydraulics Off** – turns off the hydraulic pressure at the service manifold, displays a message in the Fault Status window and lights the Aux indicator on the LUCP.
- ◆ **Interlock** – turns off the hydraulic pressure, generates an interlock signal, clamps the servovalve, and displays a message in the Fault Status window. You must correct the reason for the interlock and use the Reset button (located on the load unit control panel) to clear the interlock.
- ◆ **Customer-defined** – these actions can be defined to ramp or hold the control channel output. These actions may also be identified with a customer-defined name or as Action 5 - 10.

Note *Customer-defined actions are created with the Edit Detector Actions window.*

Sensor zero

The Lock and Unlock radio buttons disable and enable the Auto Zero function. The Lock/Unlock selection applies to the Auto Zero button and the manual adjustment in this window, and the Auto Zero button in the Display Input Signals window.

You cannot zero a sensor being used with the active control mode when hydraulic pressure is on.

The Offset field shows the amount of offset applied to the sensor (in percentage of full-scale). You can zero the sensor output manually with the slider bar or automatically with the Auto Zero button.

Continued...

Sensor zero

(...continued)

The following are examples why you may want to zero a sensor output.

LVDT sensor

Assume the LVDT is calibrated with the zero point at mid-actuator displacement. After a specimen is installed, the LVDT sensor output may not be zero. In this situation you would want to zero the output.

Force sensor

After installing a grip, you may zero the force channel to remove the effects of the weight of a grip fixture on the force sensor output.

Extensometer

Before installing an extensometer, use the zero pin or gage length fixture to establish the mechanical zero of the sensor. Use sensor zero if the sensor output is not zero.

Shunt calibration

Use shunt calibration periodically to check the accuracy of a dc sensor and associated conditioning circuit. Selecting Pos or Neg checks the appropriate calibration.

Note *You cannot check shunt calibration of a sensor being used with the active control mode when hydraulic pressure is on. See the Shunt Cal window for information any difference between the reference value and cal check value.*

You also use shunt calibration to check accuracy when you move a sensor and sensor cartridge to a different dc conditioner, or if you change the sensor cable (the cable resistance may be different).

Shunt calibration does not compensate for changes in the sensor sensitivity over time.

Ranges

Each sensor can be calibrated for more than one range. A range redefines the input channel to represent a portion of the sensor's physical capacity. You can create a range for any portion of a sensor's capacity.

Ranges represent a portion of the sensor's capacity.

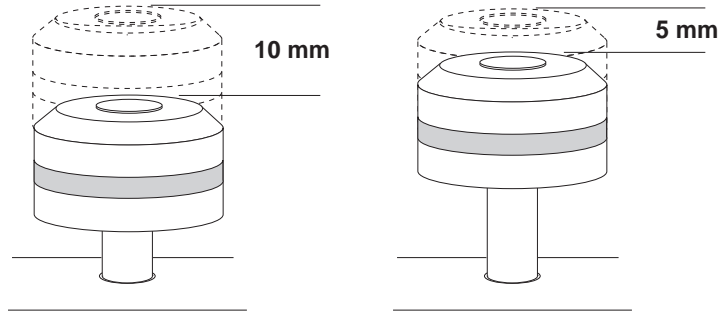

For example, assume a displacement sensor has a full-scale capacity of 10 cm. A ± 5 cm range can operate across the full-scale range of the sensor (± 5 cm). A ± 2.5 cm range of the same sensor can operate across half the capacity of the sensor (this redefines full-scale to be ± 2.5 cm).

Note Be sure you select a range large enough to accommodate the maximum sensor output expected during a test.

Select a full-scale range to optimize the maximum sensor output for a test.

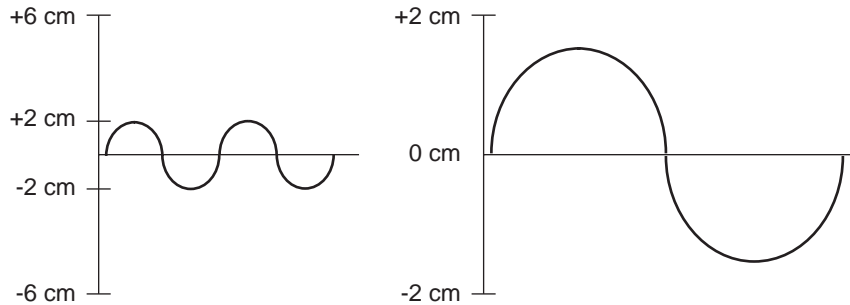

Another example: assume your test requires a ± 1.5 cm displacement. A ± 6 cm or ± 3 cm range functions properly, but ± 2 cm range provides the best resolution.

Acceleration compensation

The acceleration compensation feature can only be used for input signals that have the acceleration compensation option (p/n 481172-xx) installed. This feature is enabled during the software installation procedure (see Chapter 4 in the Installation manual).

Acceleration compensation minimizes unwanted feedback from vibration caused by the acceleration of any fixture and specimen mass attached to the force transducer. This feature is applied to force input signals. Acceleration compensation is common in the following:

- ◆ Moving load cells. The force transducer is mounted to the end of an actuator.
- ◆ Load units that operate at high frequency with massive grips.

Note *Adjust the acceleration compensation after the system has been tuned. Also, set up a Readout channel to monitor the input signal (see Output Signals Chapter 3).*

Adjustment procedure

1. **Be sure** no specimen is connected to the system.
2. Set up the function generator for a command using a displacement control mode at a frequency approximately 80% - 100% of the maximum frequency the application will use.
3. Select the force sensor to be adjusted.
4. Using a Readout channel connected to an oscilloscope, monitor the selected sensor signal.
5. Run the function generator command.
6. Adjust the Acceleration Compensation control until the signal being monitored is minimized. The signal will look like “noise.”

The adjustment isn't working

If the Acceleration Compensation control doesn't seem to make any difference (or it makes the noise worse), press the Polarity button and change the polarity of the adjustment.

If it still doesn't work, the mass attached to the force transducer may be too small and acceleration compensation may not be needed.

Set Zero Scroll Range Window

Use the Set Scroll Range window to establish a range of zero adjustment.

The default values are -100% (min.) and +100% (max.) full-scale.

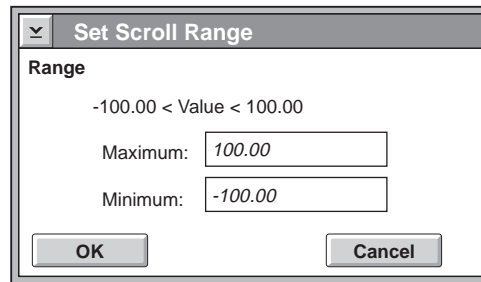

Using the window

The window displays the full-scale value of the selected control mode range. You can change the maximum or minimum setting of the Offset Zero control to a value less than full-scale. The Max. and Min. parameters can be set to different levels. To change a scroll range value, type the new value in the entry field. You cannot set the maximum range to a value less than the current Offset Zero setting or the minimum range more than the current Offset Zero setting.

For example, assume the control mode range is defined as ± 3 cm.

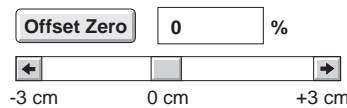

With the Max. and Min. values set to +100% and -100%, the zero reference is centered.

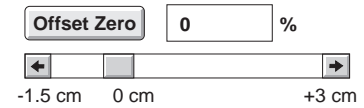

Changing the Min. setting to -50% re-scales the adjustment range to -1.5 to 3 cm. The zero reference is also offset.

Changing the range re-scales the control setting.

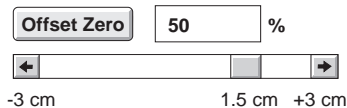

The Max. and Min. values are set to +100% and -100%, and the Offset Zero control is set to +50%.

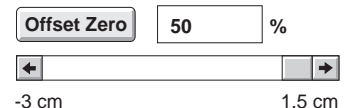

Changing the Max. setting to +50% causes the Offset Zero control to reach the maximum range.

Shunt Cal Window

A shunt calibration reference value is determined when the sensor is calibrated for use with a specific range. The reference value is usually set for approximately 80% full-scale.

Shunt calibration is used only with dc sensors. Both positive and negative shunt calibrations are supported.

This window displays the results of the shunt calibration operation.

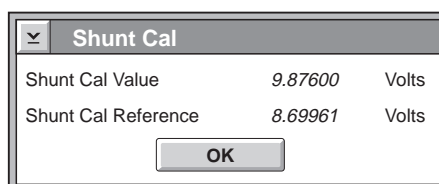

CONTROL	FUNCTION
Shunt Cal Value	Shows the value returned from the shunt calibration operation.
Shunt Cal Reference	Shows the reference value determined during the sensor calibration. The value represents the positive or negative selection in the Adjust Sensors window.

Checking shunt cal

Compare the Shunt Cal Value with the Shunt Cal Reference value to determine if the sensor requires recalibration.

- ◆ If the difference is less than 20 mV, the calibration is OK.
- ◆ If the difference is between 20 mV and 150 mV, you should adjust the excitation value in the Sensor Calibration program. Add or subtract the shunt cal difference to/from the excitation value. If other ranges of the sensor use the same excitation value, also change the excitation value for those ranges.
- ◆ If the difference is more than 150 mV, you should recalibrate the sensor with the Sensor Calibration program.

How it works

Pressing the Shunt Cal button shunts a precision resistor across one arm of the sensor bridge to create an imbalance that affects the sensor output. The imbalance produces a reference value to verify the calibration accuracy of the sensor and the integrity of the cable.

The precision resistor shunts across one arm to check positive shunt calibration or across a different arm to check negative shunt calibration.

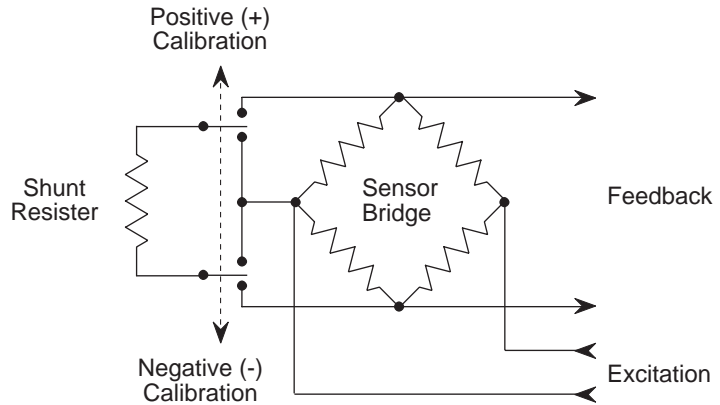

More information

Calibrating a sensor

Installation Manual (8, 9)

Determining a shunt cal reference

Installation Manual (2, 8, 9)



Tuning

CAUTION

Every control mode must be properly tuned. Using a poorly tuned control mode may cause the actuator to:

- **move so slowly it may appear not to be working,**
- **make an obnoxious noise identifying unstable operation,**
- **or in extreme cases, slam to its mechanical limit.**

Be sure you know the following before you tune:

- the Safety Precautions in the Preface of the Installation manual,
- the Tuning chapter in this manual,
- how the adjustments affect your system,
- how to use the error detector and limit detectors to help stop the system if it performs outside your expectations
- that you need to retune when testing specimens with different characteristics (rubber vs. steel).

Prerequisites

You must define a control channel (and its control modes) with the Edit Control Channels window before you can use this window.

Control channels

The number of control channels is set when the TestStar software is installed. Each control channel can have up to 10 control modes. The Tuning window opens with controls for the active control mode shown below the control mode selection.

Selecting a control mode displays the appropriate controls at the bottom of this window.

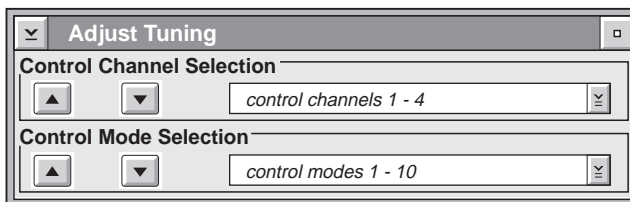

Types of control modes

The type of control mode is set when the control mode is created in the Edit Control Channels window. There are three types of control modes and they use different sets of controls.

- ◆ **PIDF** – Proportional, integral, derivative, and feed forward are a group of gain adjustments to tune the servo loop response using a single feedback source.
- ◆ **Channel Limited Channel** – A CLC control mode uses one input channel to control the servo loop (master channel) while using a second input channel (limiting channel) to restrict the master channel. The limiting channel ensures the master channel operates within a limit range. The tuning controls consist of gain controls for the master and limiting channels along with adjustments to establish the limit range.
- ◆ **Cascade** – A CASC control mode uses two feedback sources, one for an inner loop and one for an outer loop. The output of the outer loop is the input to the inner loop. Gain and rate controls tune the outer loop while gain and reset controls tune the inner loop.

Note *The inner and outer loops of a cascade control mode should not be confused with the inner and outer loops found in a system using a Series 256 or 257 Servovalve. These are two different parts of a servo loop that happen to use the same terminology.*

Auto-tuning

The auto-tuning feature is available for PIDF control modes using the segment generator (SG) command source. It produces a low to moderate level of tuning. You can then fine tune the control mode for a higher level of tuning.

More information

General tuning information	About Tuning on page 260
Auto-tuning procedure	Auto-tuning on page 281
General tuning procedure	Tuning Procedure on page 288



Tune PIDF Window

Prerequisite

You must define a PIDF control mode for the control channel with the Edit Control Channels window before you can use this window.

PIDF – proportional, integral, derivative, and feed forward are a group of gain adjustments that tune the servo loop response.

Use the PIDF control mode for specimen testing.

The proportional, derivative, and integral adjustments are also called gain, rate, and reset respectively.

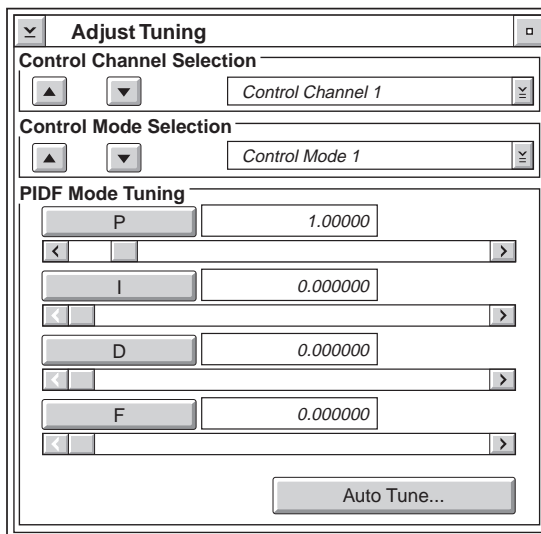

CONTROL	FUNCTION
P	Adjusts the amount of proportional gain. Proportional gain affects the servo loop response to a servovalve command.
I	Adjusts the amount of integral gain. Integral gain affects the system steady-state (dc) error.
D	Adjusts the amount of the derivative gain. Derivative gain affects stability at higher proportional gain settings.
F	Adjusts the amount of feed forward gain. Feed forward affects the system performance at high frequency operation.
Auto-tune	Displays the Auto-tune window where you configure the auto-tune feature. This feature is only available with the PIDF control modes.

Changing the adjustment range

Pressing any of the adjustment buttons displays the Set Scroll Range window where you can change the adjustment range of the slider boxes. Each adjustment can have a different range.

How it works

This is a block diagram that shows the interrelationships of the various gain controls

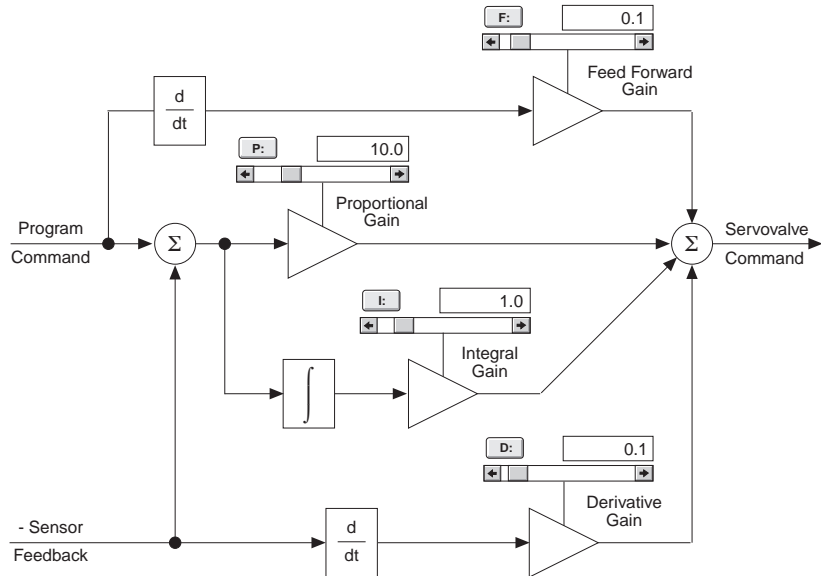

Using the controls

You should be familiar with the concept of tuning the servo loop before you attempt to adjust the tuning controls. The following is a tuning guideline:

Note Go to Chapter 9 to determine an appropriate tuning strategy for your system and specimen.

1. Install a dummy specimen. If a displacement control mode is to be tuned, a specimen is not required.
2. Select the control mode you want to tune.
3. Set up the Function Generator (or select a TestWare-SX test procedure) for your test command.
4. Set up the TestStar scope or an oscilloscope to view the sensor feedback of the selected control mode.
5. Start the test command and adjust the tuning controls for the ideal response.

Auto Tuning

The auto-tuning feature automatically tunes control modes for a moderate level of tuning.

Prerequisite

The auto tuning feature is only available for PIDF control modes using the segment generator (SG) command source.

Pressing the Auto-tune button in the Adjust Tuning window displays the Auto Tuning window

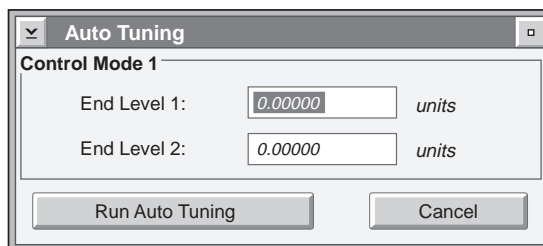

End levels

The end levels represent the limits of the signal that exercises the actuator. Set the end levels to the upper and lower amplitude values that are expected for the control mode during the test. While the auto tuning control mode moves the actuator, the input signal for the control mode that is being tuned is monitored so the actuator doesn't cause a command that exceeds the end levels.

How it works

Auto tuning uses an auto tuning control mode to control the actuator while the selected control mode is being tuned. The auto tuning control mode is selected in the Edit Control Channels window. The first control mode to be tuned should normally be a displacement or angular control mode.

Auto tuning begins by moving the actuator using the auto tuning control mode. While the actuator is moving, the feedback for the control mode being tuned is monitored to determine the response of the control mode. Once the feedback is evaluated, tuning parameters are calculated. The tuning values are displayed in the Accepting New Gains window.

Note See [Auto-tuning](#) on page 281 for procedures to use this feature.



Tune CLC Window

Prerequisite

You must define a CLC control mode for the control channel with the Edit Control Channels window before you can use this window.

Channel-Limited-Channel (CLC) tuning controls establish the response of the servo control loop for specimen installation (and removal) using the load unit control panel.

Also use this window to establish an operating range for the limiting channel.

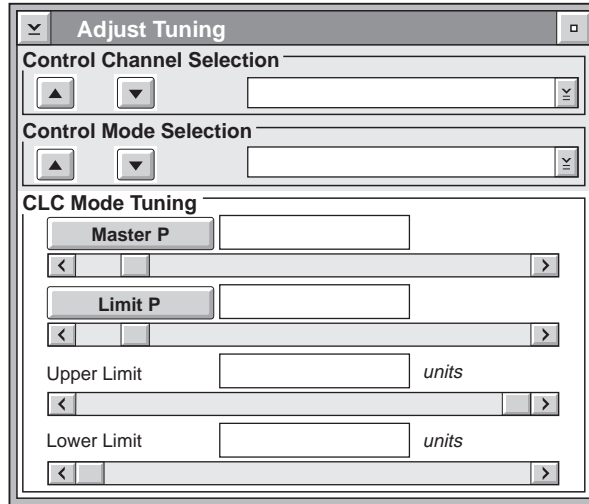

CONTROL	FUNCTION
Master P	Adjusts the gain of the master control channel.
Limiting P	Adjusts the gain of the limiting control channel.
Lower Limit Upper Limit	Defines a range for the limiting control channel. The limiting channel range ensures the command does not exceed the upper and lower limit values. You select values based on the modulus of the specimen.
Units	Shows the units of the upper and lower limit values. The units are set by the input signal used for the master and limiting control modes.

Changing the adjustment range

Pressing the Master P or Limiting P button displays the Set Scroll Range window where you can set the range of adjustment for the control. Each adjustment can have a different range.

How it works

A CLC control mode uses one input channel to control the servo loop (master channel) while using a second input channel (limiting channel) to restrict the master channel.

The limiting channel uses a limit range to ensure the servovalve command cannot exceed the range set for the limiting channel.

A CLC control mode can be used only with the Actuator Positioning Control on the load unit control panel.

The CLC control mode uses one of three error signals.

The Limit P: adjustment acts as a conversion factor to scale the limit feedback to similar units as the master feedback.

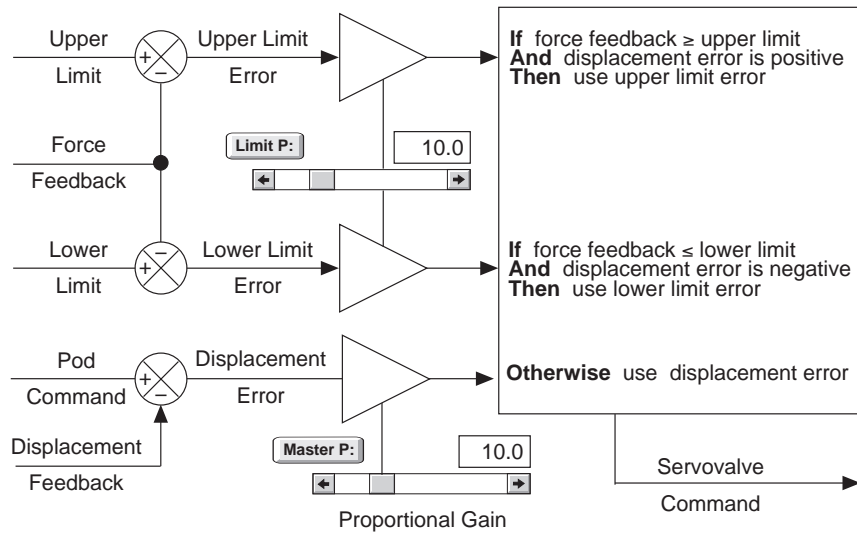

CLC example

Assume you have a ± 3 cm displacement sensor (LVDT), an 11 kN force sensor, and phasing that produces tension with a positive command.

A typical CLC control mode uses length as the master channel and force as the limiting channel. The upper limit is set to 1 kN and the lower limit is set to -2 kN. The LUC is selected for specimen insertion control. The specimen is installed in one of the grips.

As you adjust the Actuator Positioning Control on the LUC, the specimen moves towards the other grip (compression) in displacement control. When the specimen starts to contact the grip, the force increases. When force reaches -2 kN, and you continue to adjust the control, nothing happens. The displacement value that caused the force limit is maintained and will not increase.

After the specimen is gripped and you adjust the Actuator Positioning Control for tension, the lower limit value ensures the tension does not go beyond 1 kN.

Using the controls

A CLC (channel limited channel) control mode receives a program command from the Actuator Positioning Control on the load unit control panel. A typical CLC control mode uses length as the master channel and force as the limiting channel.

Note *The easiest way to tune a CLC mode is to use the proportional gain (P) values from any tuned PIDF control mode (of the same signal type) for the master P and limiting P values.*

The following is a tuning guideline assuming the Master feedback is displacement and the Limiting channel is force.

- ◆ Adjust the Master P control for adequate actuator response when adjusting the Actuator Positioning Control.
 - ◆ Monitor the force output and adjust the limiting channel control to minimize any delay to stop actuator movement when it reaches the specified limit.
-



Tune CASC Window

Prerequisite

You must define a CASC control mode for the control channel with the Edit Control Channels window before you can use this window.

Cascade control mode adjustments tune the response of both servo loops.

Use the CASC control mode for specimen testing that requires a high degree of stability (such as dynamic load applications).

The inner and outer loops are not the same as those used with 3-stage servo valves.

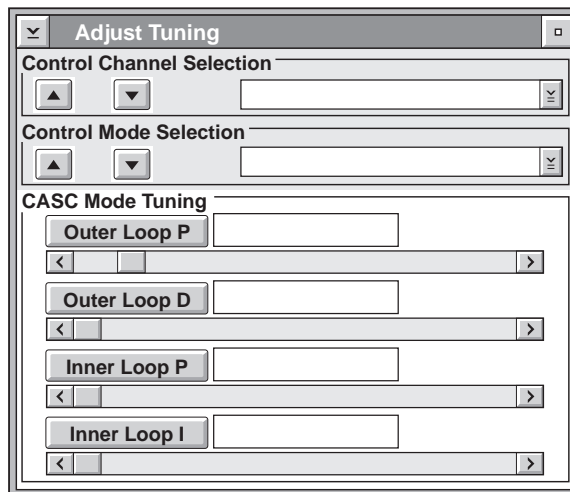

CONTROL	FUNCTION
Outer Loop P	Adjusts the level of proportional gain for the outer loop. Proportional gain affects the servo loop response to a servovalve command.
Outer Loop D	Adjusts the level of the derivative gain for the outer loop. Derivative gain affects stability at higher proportional gain settings.
Inner Loop P	Adjusts the level of proportional gain for the inner loop.
Inner Loop I	Adjusts the level of integral gain. Integral gain affects the system steady-state (dc) error.

Changing the adjustment range

Pressing any of the adjustment buttons displays the Set Scroll Range window where you can change the adjustment range of the slider boxes. Each adjustment can have a different range.

How it works

A cascaded control mode uses any two sensor feedback signals. The outer loop has proportional gain (P) and rate (D) adjustments. The inner loop has proportional gain (P) and reset (I) adjustments.

The cascaded control mode uses two feedback sources, displacement usually controls the inner loop and force usually controls the outer loop.

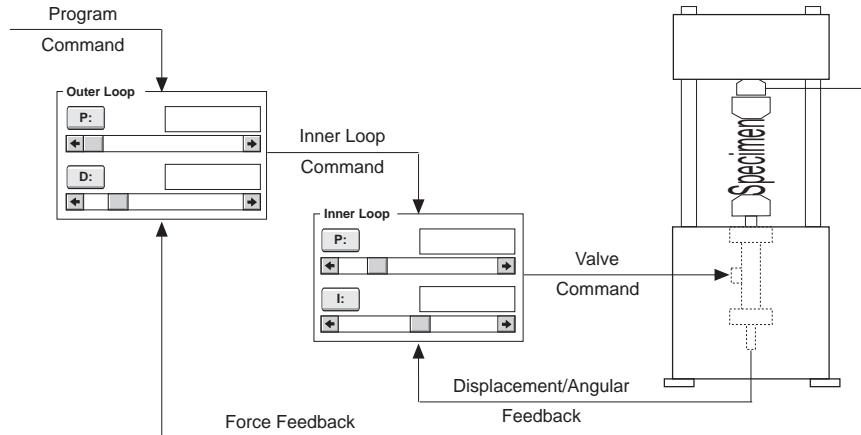

Using the controls

You should be familiar with the concept of tuning the servo control loop before you attempt to adjust the tuning controls. The following is a tuning guideline:

Note Go to Chapter 9 to determine an appropriate tuning strategy for your system and specimen.

1. Install a dummy specimen. If a displacement control mode is to be tuned, a specimen is not required.
2. Select the control mode you want to tune.
3. Select a tuned PIDF control mode that uses the same feedback as the inner loop (typically length) and record P and I values. Enter these values for the P and I controls of the inner loop.
4. Set up the Function Generator (or select a TestWare-SX test procedure) for your test command.
5. Set up the TestStar scope or an oscilloscope to view the sensor feedback of the selected control mode.
6. Start the program command and adjust the outer loop P control to produce about 10% over-shoot.
7. Increase the Outer Loop D control slowly until the over-shoot disappears.

Set Scroll Range Window

Setting the scroll range for the tuning controls can ensure the controls are not adjusted beyond a desired range. Reducing the scroll range also increases the resolution of the control adjustment.

The Set Scroll Range window reduces the range of the selected control in the Tune windows.

The value $3.40282e+38$ is the maximum value supported by the computer.

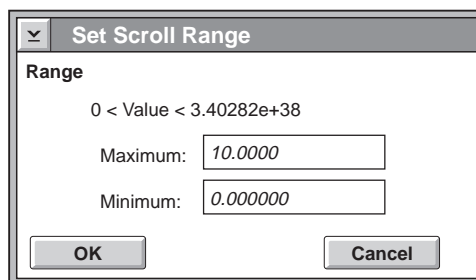

Using the window

The window displays the current setting for the control (all controls are initially set to 10). You can change the minimum or maximum setting to any value above zero. To change the scroll range value, type the new value in the entry field.

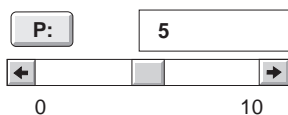

The P control is set to 5 with the scroll range set at 10.

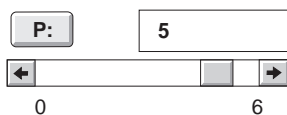

Changing the scroll range to 6 changes the reference of the control setting (5).

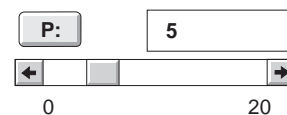

Changing the scroll range to 20 also changes the reference of the control setting (5).

Do not increase the scroll range unless the maximum adjustment proves to be inadequate. Increasing the scroll range reduces the resolution of the adjustment.



Adjust Compensators

The Adjust Compensators window provides adjustments for the peak/valley compensator and phase/amplitude compensator (PAC). The compensators are methods that ensure the command end levels are reached.

This window lets you adjust the peak/valley and PAC (phase and amplitude) compensation functions.

Each selection displays the appropriate adjustments at the bottom of the window.

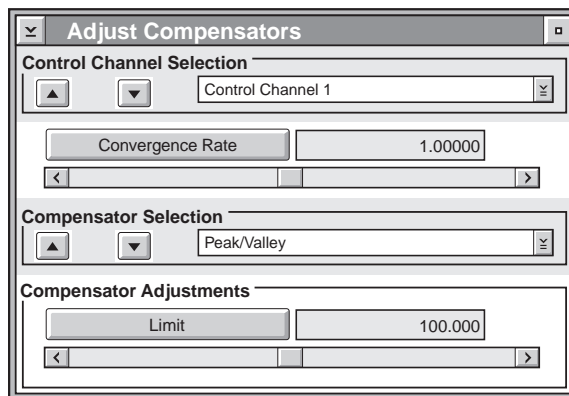

CONTROL

FUNCTION

Control Channel Selection	Selects the control channel for compensation adjustment.
Compensator Selection	Selects the type of compensation method to be adjusted. None disables compensation. Peak/Valley provides amplitude/mean control. PAC provide phase and amplitude control. It must be enabled with the Edit Control Channels window before it is listed here.
Convergence Rate	Sets how quickly the differences between the command and sensor feedback are reduced.
Limit	Limits the maximum amount of PAC compensation. The peak/valley compensator has a fixed limit.

Compensators

Compensators compare the sensor feedback to the test command to determine if the command signal is producing the required physical effect on the specimen. Compensators can provide specific types of correction to ensure the command is properly applied to the specimen. The compensator adjustments are like additional tuning adjustments.

- ◆ The compensators are selected and used in the TestStar Function Generator, the TestWare-SX cyclic command process, and the optional mixed mode sine process.

Note *Be sure to disable any compensation when tuning.*

Peak/Valley

This compensator detects any amplitude roll-off and any difference in the mean level. Amplitude roll-off is the difference between the amplitude of the command and the amplitude measured by the sensors. This can also cause a mean level difference.

- ◆ Peak/Valley compensation is available only for cyclic commands (this includes sine, triangle and square waveforms).
- ◆ Peak/Valley compensation is available on all channels. It uses very little of the system resources and doesn't slow down the sampling rate (servo loop update rate).

PAC

This phase and amplitude compensator detects any amplitude roll-off and any phase lag. Amplitude roll-off is the difference between the amplitude of the command and the amplitude measured by the sensors. Phase lag refers to the time lag between the command producing a physical event and the measured response from a sensor.

- ◆ PAC is available only for sinusoidal command waveforms. It expects the feedback to be balanced about a mean level (some Reset (I) adjustment may be necessary).
 - ◆ PAC compensation is available only on channels that have PAC enabled in the Edit Control Channels window. Its computational requirements may limit the sampling rate on multi-channel systems.
-

Convergence rate

The convergence rate controls how quickly the feedback signal is matched with the command signal. Convergence will occur eventually (if rate is not set to zero), this adjustment determines how fast it occurs.

- ◆ A typical peak/valley range for the convergence rate is 0.2 to 0.8. The default setting of 0.5 should work fine for most applications.
- ◆ The range for PAC varies according to the frequency of the command. At low frequencies, a range of 1 - 20 can be appropriate while at high frequencies (500 - 1000 Hz), the range can reach as high as 200. The default is set at 1.
- ◆ Set up a meter to monitor the span/mean of the feedback. If span of the command is not being reached fast enough, increase the convergence rate. If the span seems to hunt for the proper span (the span varies above and below the command span), decrease the convergence rate.
- ◆ If the rate is too low, convergence occurs very slowly.
- ◆ If the rate is too high, instability can occur at some frequencies.

Amplitude error refers to the tendency of amplitudes measured by the sensors to be less than the desired amplitudes. Phase lag refers to the tendency of the feedback signal to trail the command signal.

When Peak/Valley is the selected compensator, the convergence rate applies to the signal amplitude and mean. When PAC is the selected compensator, the convergence rate applies to both amplitude and phase.

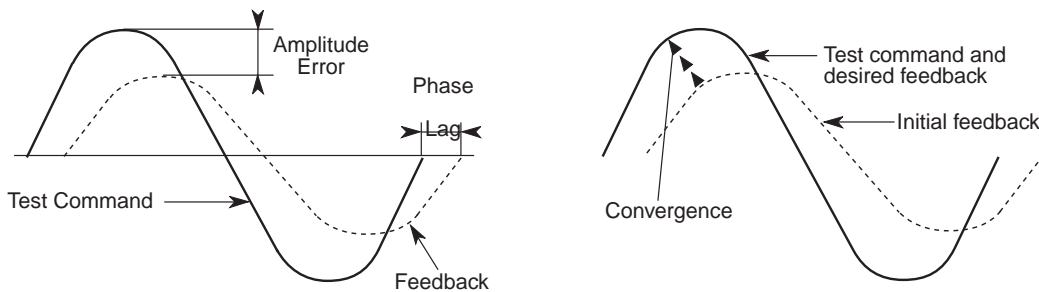

The amplitude error and phase lag are determined when the feedback is compared to the test command. When the convergence rate is properly adjusted, the feedback signal converges to the command rapidly without instability. If the max. limit is set too low, convergence may not be possible.

Limit adjustment

The Limit setting establishes how much amplitude compensation is available through PAC. The limit value represents a multiplier of the command. A setting of zero results in a command of zero.

For example, assume a command with an amplitude of 4 mm and a limit setting of 2. The maximum boost the compensator can produce is 8 mm.

Use the following as a guideline to set the Limit adjustment.

1. Set up a test that runs your system at the maximum command and frequency expected during the test.
2. Monitor the feedback for the control mode.
3. Start the Limit at 10. Increase the Limit until the feedback equals the test command. Increase the setting another 20% to provide an operating margin.

Note Ideally, adjust the Limit to the smallest value that allows you to reach your command end levels. This insures stability and allows you to detect changes in your system.

Assume the limit is set at 2,

If the test command must be boosted 6 mm to achieve the desired 2.5 mm amplitude, the command is clipped at 5 mm.

The limit should be increased to 3.

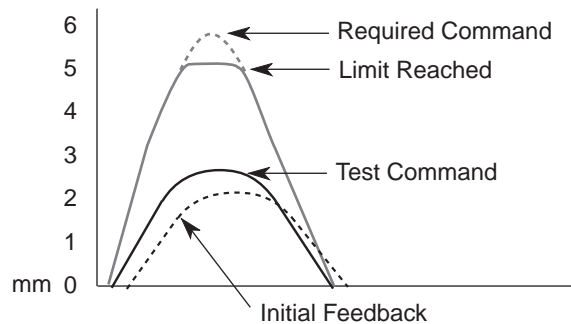

Changing the adjustment range

Pressing any of the adjustment buttons displays the Set Scroll Range window where you can change the adjustment range of the slider box. Each adjustment can have a different range.



Error Detectors

⚠ WARNING

The HPS can cause unexpected actuator movement in systems where TestStar does not control the HPS.

Be sure to use the error detector as an interlock if hydraulic pressure is lost and later restored while TestStar is running.

Prerequisites

You must define an input signal and a control channel with the Edit menu before you can use the Error Detectors window. Use the error detectors to detect changes in the specimen characteristics during a test.

Use this window to set up to two error detectors for each PIDF control mode. Each error detector monitors the level of error between the test command and the sensor feedback signal for the associated control mode.

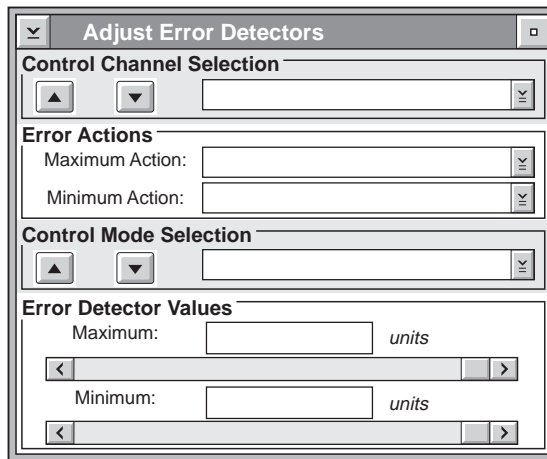

CONTROL

FUNCTION

Control Channel

Selects a control channel. Each control channel has two error detectors that can have different values assigned to each control mode.

Actions

Selects the actions for the selected control channel. The actions apply to all control modes.

Control Mode

Selects a control mode. Each control mode has 2 error detectors.

Error Values

Sets a maximum and minimum value for the selected control mode. The units are set by the input signal defining the control mode.

How it works

The error detector monitors the difference between the test command and a feedback signal. The amount of error indicates how closely the system tracks the test command.

As a specimen changes (approaching failure) the amount of error will likely increase. The purpose of an error detector is to warn you that a specimen is beginning to fail, or to shut down the test before the specimen breaks (which can cause equipment damage).

- ◆ If an error exceeds the level you set, the digital controller performs the action you choose (disabled, indicate, hydraulics off, interlock, customer-defined).
- ◆ An effective error detector requires the servo control loop to be properly tuned.
- ◆ For static or low-frequency tests, the error detector is typically set to a low level.
- ◆ At high frequencies, the error detector is used to detect loss of closed-loop control. Set the error detector to a high level.

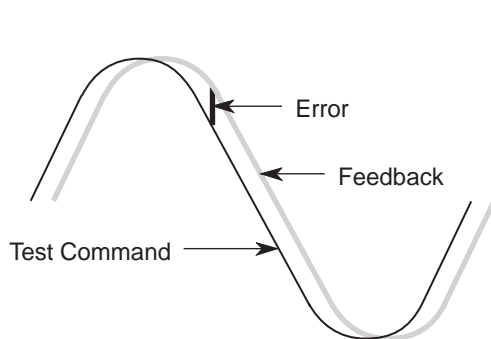

At higher frequencies the error level is large. The phase lag of the feedback creates a larger error.

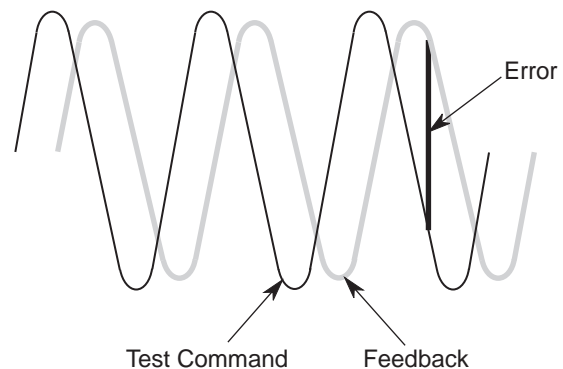

At lower frequencies the error level is usually small. The feedback tracks the command more closely.

- ◆ Use the minimum error to indicate an approaching failure.
- ◆ Use the maximum error to perform an appropriate action.

Actions

An action determines what happens when the associated limit level is crossed. Select the action you want to occur when an error is detected. You can assign an action for each error. The following are the actions you can use:

- ◆ **Disabled** – turns the error detector off.
- ◆ **Indicate** – displays a message in the Fault Status window that the detector has been triggered.
- ◆ **Hydraulics Off** – turns off the hydraulic pressure at the service manifold, displays a message in the Fault Status window and lights the Aux indicator on the LUCP.
- ◆ **Interlock** – turns off the hydraulic pressure, generates an interlock signal, clamps the servovalve, and displays a message in the Fault Status window. You must correct the reason for the interlock and use the Reset button (located on the load unit control panel) to clear the interlock.
- ◆ **Customer-defined** – these actions can be defined to ramp or hold the control channel output. These actions may also be identified with a customer-defined name or as Action 5 - 10.

Note *Customer-defined actions are created with the Edit Detector Actions window.*

Using the window

When using both error detectors, set the Minimum error to a value that indicates the onset of a failure at a lower error level and configure the Maximum error to a value that stops the test at a higher error level. Perform the following for each control channel.

1. Select a control channel using the step switches or the list icon.
2. Select an appropriate action for each error detector.

Note *Repeat the following steps for each control mode.*

3. Select a control mode using the step switches or the list icon.
4. Use the scroll bars or enter a value in the entry field to establish the Minimum and Maximum values for the selected control mode.
5. Repeat steps 1 - 4 for any other control channels.

Underpeak Detectors

An underpeak detector monitors an input signal during cyclic tests only.

Prerequisites

You must define an input signal and a control channel with the Edit menu before you can use the Underpeak Detectors window.

Use this window to define an acceptable minimum operating range for a control channel.

Each control channel can have an underpeak detector.

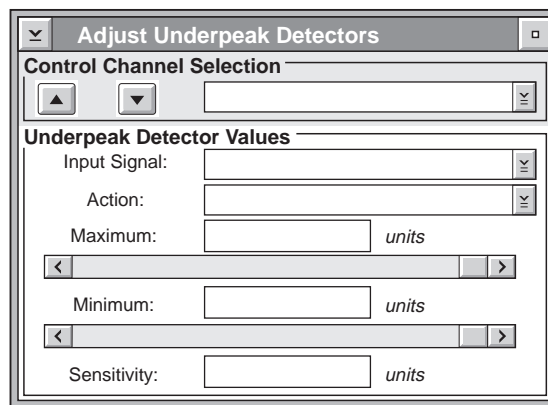

CONTROL	FUNCTION
Control Channel	Selects a control channel. Each control channel can have one underpeak detector.
Action	Selects the action that the Underpeak detector takes when the detector triggers.
Input Signal	Selects an input signal for the detector. The units of the input signal are automatically set for the maximum and minimum values.
Maximum Minimum	Sets values of the underpeak Minimum and Maximum parameters within the range of the selected input signal.
Sensitivity	Determines when the maximum or minimum value is detected. The sensitivity setting is the amount the signal must change to detect a maximum or minimum value.

How it works

The underpeak detector monitors an input channel to ensure the sensor feedback achieves a specified range. Underpeak is used with cyclic tests. The purpose of the underpeak settings is to detect a sensor output that is changing from the normal operating range.

For example, underpeak detection is used to stop the test at the onset of failure in a fatigue test or to detect inadequate servo loop control (peaks not being reached).

- ◆ Two underpeak levels are set. A minimum and a maximum level establish a range the channel output must achieve each cycle.
- ◆ Underpeak levels are set to stop the test when a specimen fails or excessive deformation causes a failure (according to material testing standards).
- ◆ Only one channel can be selected for underpeak detection.
- ◆ If an underpeak level is not reached, the digital controller performs the selected action.
- ◆ Set the interlock action after the test starts. The detector may trip when the test program ramps to a testing amplitude.

The feedback signal must exceed an underpeak level before it crosses the underpeak mean level. If not, an underpeak detection occurs.

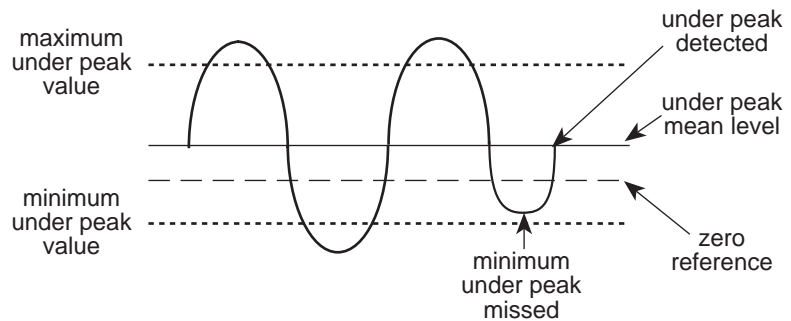

Maximum Minimum

Both minimum and maximum values must be entered to define a range. The range represents maximum (peak) and minimum (valley) values the input channel must achieve each cycle. Maximum underpeak is the most positive (least negative) value and Minimum underpeak is the most negative (least positive) value.

Actions

An action determines what happens when an underpeak has been detected. Refer to Chapter 1 for instructions on how to reset actions. The following are the actions you can use:

- ◆ **Disabled** – turns the error detector off.
- ◆ **Indicate** – displays a message in the Fault Status window that the detector has been triggered.
- ◆ **Hydraulics Off** – turns off the hydraulic pressure at the service manifold, displays a message in the Fault Status window and lights the Aux indicator on the LUCP.
- ◆ **Interlock** – turns off the hydraulic pressure, generates an interlock signal, clamps the servovalve, and displays a message in the Fault Status window. You must correct the reason for the interlock and use the Reset button (located on the load unit control panel) to clear the interlock.
- ◆ **Customer-defined** – these actions can be defined to ramp or hold the control channel output. These actions may also be identified with a customer-defined name or as Action 5 - 10.

Note *Customer-defined actions are created with the Edit Detector Actions window.*

Sensitivity

Sensitivity is the amount of change the signal must change to detect a peak or valley.

- ◆ **If set too low:** Signal noise will incorrectly be recognized as a valid change.
 - ◆ **If set too high:** A small but valid change will not be recognized.
-



Adjust Drive

The drive adjustments optimize the interface between the digital controller and a specific drive type. TestStar supports *hydraulic* and *electro-mechanical* drive configurations. Each configuration can have several kinds of drives associated with it.

Prerequisite

You must define a control channel with the Edit Control Channel window before you can use a drive window. The Adjust Drive window that is displayed depends on the Drive Type selection in the Edit Control Channel window.

During the software installation, the system configuration choice defines your system as a hydraulic or an electro-mechanical system. This identifies the type of equipment in your system and adjusts the TestStar windows accordingly.

Hydraulic systems

Hydraulic systems use servovalves to control the actuator. The following complement of valves have different drive windows:

- ◆ **252 Valve** – represents the MTS Series 252 Servovalve.
- ◆ **Dual 252 Valve** – represent two MTS Series 252 Servovalves mounted to the actuator manifold.
- ◆ **256/257 Valve** – represents the MTS Series 256 and Series 257 Servovalves. Although these valves differ, they use the same adjustments.

Electro-mechanical systems

Electro-mechanical systems use servo motors to control the actuator instead of hydraulics. Electro-mechanical systems replace the term “hydraulic” with “motor” throughout the TestStar windows.



Adjusting 252 and Dual 252 Valves

This window adjusts the Valve Driver module for use with a Series 252 Servovalve.

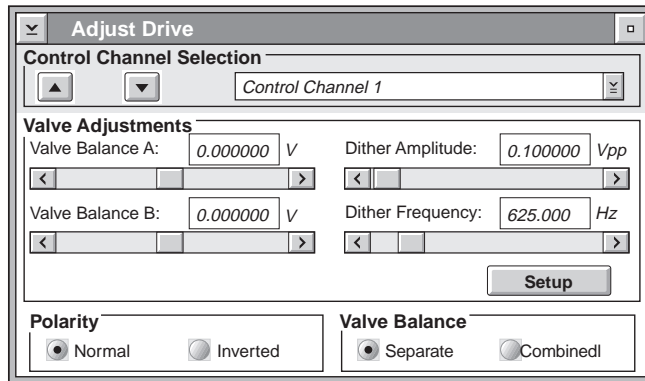

CONTROL	FUNCTION
Valve Balance A *Valve Balance B	Electrically compensates for minor mechanical unbalance in the servovalve.
Dither Amplitude	Adjusts the amount dither needed to overcome friction in the servovalve. Dither is most effective for static and low-frequency tests.
Dither Frequency	Adjusts the dither frequency. The operating frequency of the system can affect the dither frequency setting. The typical dither frequency for a Model 252 Servovalve is 500 - 700 Hz (625 Hz is nominal).
Setup	Displays the following controls. <i>See Appendix B in the Installation manual.</i> Polarity – selects the polarity of the signal driving the servovalve. DO NOT change the setting unless performing the servo loop phase check. *Valve Balance – selects how the valve balance controls operate. Select Separate to adjust each control individually. Select Combined to adjust both controls simultaneously.
*Valve Balance B and Valve Balance controls appear only when the dual 252 Drive Type is selected in the Edit Control Channels window.	

Adjusting valve balance

To adjust the valve balance, perform the following using the controls on the load unit control panel (with no specimen installed):

1. Auto zero force.
2. Set up for a Force Pod control mode.
3. Monitor the force sensor output on the display.
4. Turn On the Actuator Positioning Control.
 - ◆ If the actuator holds its position, valve balance is not needed.
 - ◆ If the actuator moves, adjust the valve balance.

Note *Perform a mechanical adjustment if the electrical valve balance cannot be achieved. Go to the appropriate servovalve product manual for the mechanical valve balance procedure.*

When a mechanical valve balance is complete, perform this procedure again.

5. Adjust the Valve Balance control to stop the actuator movement. Make the adjustment before the actuator reaches its maximum displacement; otherwise, you will need to reposition the actuator and continue the adjustment.

Dither

While running a test on a properly tuned system, you observe either of the following:

- ◆ A sinusoidal test waveform is distorted at its maximum and minimum points (peak and valley values change). This will normally be more observable during a test that has either a low-frequency or a low-amplitude test waveform. Dither amplitude is insufficient. See Adjusting dither amplitude.
- ◆ You hear a really annoying sound that irritates your nerves as much as a fingernail continuously scraping a blackboard. Dither amplitude is excessive. See Adjusting dither frequency.

Adjusting dither amplitude

To adjust dither amplitude, perform the following (no specimen is needed):

1. Set up the Function Generator for a very slow ramp in length control.
2. Set up an oscilloscope to monitor the system response.
3. Run the Function Generator.
 - ◆ If the system response indicates a smooth ramp, adjusting the dither amplitude is unnecessary.
 - ◆ If the system response indicates a jagged ramp (the actuator sticks before moving) adjust the dither amplitude.
4. Increase the dither amplitude until the system response becomes smooth.

Adjusting dither frequency

Dither frequency is adjusted in conjunction with the dither amplitude. The following is an adjustment guideline (no specimen is needed):

1. Set up the Function Generator for a very slow sine wave in length control.
2. Set up an oscilloscope to monitor the system response. Be sure you have an output channel defined.
3. Run the Function Generator.
 - ◆ If the system response indicates a smooth waveform, adjusting the dither frequency is not needed.
 - ◆ If the system response indicates a jagged waveform or if the dither amplitude can be detected on a scope, adjust the dither frequency.
4. Adjust the dither frequency until the system response becomes smooth.
 - ◆ If dither frequency is adjusted too low, the dither amplitude can be detected.
 - ◆ If the dither frequency is adjusted too high, the effects of dither are negated (the system response indicates a jagged waveform).



Adjusting 256 and 257 Valves

The MTS Series 256 and 257 Servovalves include an inner loop. The additional controls for this type of servovalve set up and tune the inner control loop.

Note The valve balance, dither amplitude, and dither frequency controls are the same for the 252 valves. They may be adjusted periodically or to fine-tune a system. The procedures are located on the preceding pages.

The other controls are set when the TestStar system is installed. Go to Appendix B in the Installation manual to setup the servovalve.

This window adjusts the Valve Driver module for use with a Series 256 or 257 Servovalve.

The screenshot shows the 'Adjust Drive' software window. At the top, there is a dropdown menu for 'Control Channel Selection' set to 'Control Channel 1'. Below this is the 'Valve Adjustments' section, which includes several numerical input fields and sliders:

- Valve Balance: 0.000000 V
- Dither Amplitude: 0.100000 Vpp
- Dither Frequency: 625.000 Hz
- Spool Zero: 0.000000 V
- AC Gain: 1.00000
- Rate Gain: 0.000000
- Inner Loop Gain: 1.00000
- Inner LoopPhase: 0.000000 deg

Below the numerical fields are four radio button groups:

- Polarity:** Normal (selected) and Inverted.
- Integrator:** In (selected) and Out.
- Inner Loop Phase:** Normal (selected) and Inverted.
- Rate Amplifier Signal:** Error (selected) and Spool Position.

A 'Setup' button is located at the bottom right of the 'Valve Adjustments' section.

CONTROL	FUNCTION
Valve Balance	Electrically compensates for minor mechanical unbalance in the servovalve.
Dither Amplitude	Adjusts the amount dither needed to overcome friction in the actuator. Dither is most effective for static and low-frequency tests.
Dither Frequency	Adjusts the dither frequency. The operating frequency of the system can affect the dither frequency setting. The typical dither frequency is 700 to 900 Hz.
Spool Zero	Adjusts the electronic null of spool position signal to match the mechanical null position of the servovalve pilot spool.
AC Gain	Calibrates the maximum valve LVDT feedback signal for 10 volts. This adjustment can affect the PIDF settings and the noise sensitivity of the valve command.
Rate Gain	Adjusts the level of derivative gain for the inner loop. The rate derivative gain affects stability at higher inner loop gain settings.
Inner Loop Gain	Adjusts the level of proportional gain for the inner loop. Proportional gain affects the inner loop response of the pilot valve.
Inner Loop Phase	Matches the phase of the inner loop LVDT feedback with 10 kHz demodulator reference signal. Adjust this for a maximum output for the maximum LVDT spool offset
Setup	Displays the following controls at the bottom of this window.
Phase	Selects the phase of the signal driving the servovalve.
Inner Loop Polarity	Selects the polarity of the inner loop feedback signal.
Integrator	Enables/disables the reset integrator of the inner loop.
Rate Amplifier Signal	Selects the signal that is input to the rate circuit. Select Spool Position for most applications. Select Error if a higher rate response is needed.



TestStarTM II

Control System

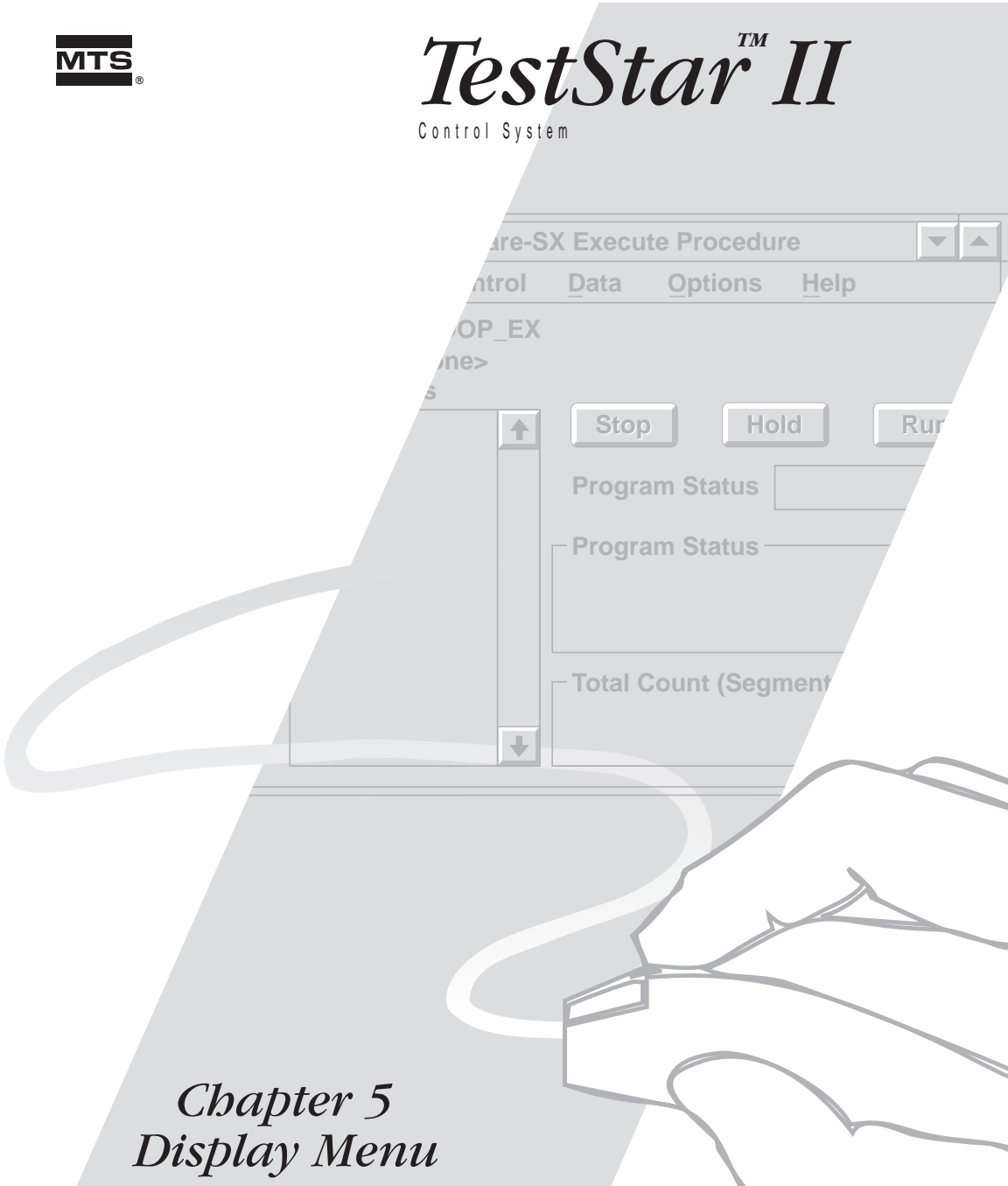

Chapter 5 Display Menu

Display Input Signals

Signal	Zero	Range
Load	0.000000 units	<input type="checkbox"/>
Stroke	0.000000 units	<input type="checkbox"/>
Calculated 1	0.000000 units	<input type="checkbox"/>
External Length	0.000000 units	<input type="checkbox"/>

Some types of input signals do not have Zero or Range controls.

TestStar

File Edit Adjust Display Help

HPS Pressure: off/low/high
Hydraulics: off/low/high
APC State: off/on

Input Signals
Detector Actions
Meter
Scope

Display Detector Actions

Detectors Limits Control

Channel Underpeak Minimum Error Maximum Error

axial disabled indicate interlock
torsional action 5 hydraulic off

Selecting Limits or Control changes this window

Display Detector Limits

Detectors Limits Control

Signal	Upper Limit	Lower Limit
load	value disabled	value action 5
stroke	value indicate	value action 6
calculated 1	value interlock	value action 7
external Length	value hydraulic off	value action 8

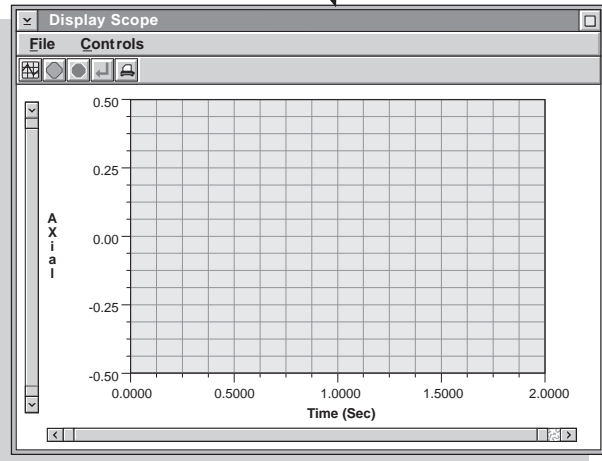

Display Meters

Controls Alignment

stroke		stroke	
Span	0.000000 in	Span	0.000000 in
Mean	0.000000 in	Mean	0.000000 in
stroke		Control Channel 1: Valve	
Peak	0.000000 in	Maximum	0.000000 V
Valley	0.000000 in	Minimum	0.000000 V

Displays 1 to 4 meters horizontally, vertically, or in a box like this.

Chapter 5

Display Menu

Use the Display menu to monitor test-related signals or change detector actions.

Contents	Display Input Signals	190
	Display Detector Actions	193
	Display Meters	196
	Display Scope	198
	Set Scroll Range Window	200
	Scope Display Options Window	201

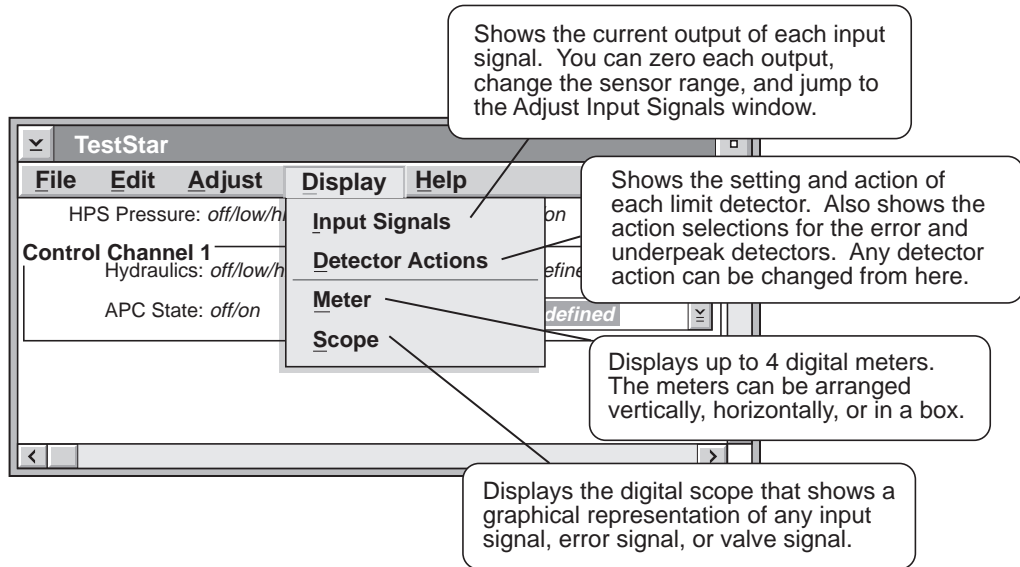

Display Input Signals

This window concentrates information from each of the Adjust Input Signals windows into a single window.

Prerequisite

You must define the input signals with the Edit Input Signals window before you can use the Display Input Signals window.

Use this window to monitor the output of each input signal. You can also zero each output or change ranges.

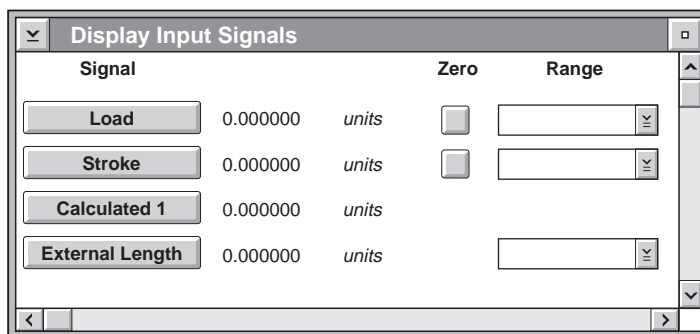

SELECTION

FUNCTION

Signal

Lists the names of the input signals. The signal names are assigned in the Edit Input Signals window.
Pressing a signal button displays the Adjust Input Signals window where you can adjust the test parameters of the input signal.

Current Output

Displays the current output of the input signal (sensor).

Zero

Allows you to zero the sensor output when the button is present and enabled.
This control is enabled or disabled in the Adjust Input Signals window.

Range

Selects the range of the input signal. Choose the range with the highest resolution for the test – the range that is closest to, but greater than the maximum expected output for the test.

Signal

All signals defined with the Edit Input Signals window are listed at the left of the window. Some types of signals do not have all the display functions available.

- ◆ **Calculated input signals** cannot be zeroed because they are created using one or more of the existing input signals; they also have no ranges associated with them.
- ◆ **External input signals** cannot be zeroed because a zero condition cannot be assured when the circuit that applies the zero correction is located outside the TestStar environment.

Zero

All input signals associated with an AC or DC conditioner plugged into the TestStar chassis have a zero button. The button is enabled and disabled (dimmed or grayed out) with the Adjust Input Signals Window.

- ◆ An input signal that is defined as Calculated or External does not have a zero button available.

Pressing an enabled Zero button zeros the current output of the input signal. This redefines the reference for zero to be the current sensor position and output.

Note *You cannot zero a sensor being used with the active control mode when hydraulic pressure is on. Also, do not zero a "cold" system. The actuator should be cycled so silting doesn't affect the zero function.*

The following are examples why you may want to zero a sensor output:

LVDT sensor

Assume the LVDT is calibrated with the zero point at mid-actuator displacement. Also assume that after the specimen is installed, the LVDT sensor output is not at zero. In this situation you would want to zero the output.

Force sensor

After installing a grip, you may zero the force channel to remove the effects of the grip tare weight on the force sensor output.

Extensometer

Before installing an extensometer, use the zero pin or gage length fixture to establish the mechanical zero of the sensor. Use sensor zero if the sensor output is not zero.

Ranges

Each sensor can be calibrated for more than one range. A range redefines the input channel to represent a portion of the sensor's physical capacity. You can create a range for any portion of a sensor's capacity.

Ranges represent a portion of the sensor's capacity.

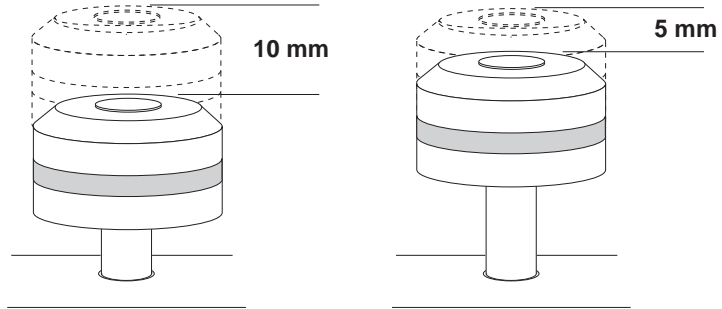

For example, assume a displacement sensor has a full-scale capacity of 10 cm. A ± 5 mm range can operate across the full-scale range of the sensor (± 5 mm). A ± 2.5 mm range of the same sensor can operate across half the capacity of the sensor (this redefines full-scale to be ± 2.5 mm).

Note Be sure you select a range large enough to accommodate the maximum sensor output expected during a test.

Select a full-scale range to optimize the maximum sensor output for a test.

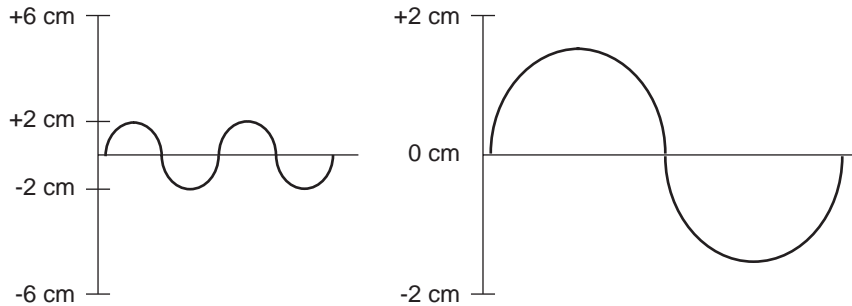

Another example: assume your test requires a ± 1.5 cm displacement. A ± 6 cm or ± 3 cm range functions properly, but a ± 2 cm range provides the best resolution.

Display Detector Actions

The detector actions window puts all the detector action selections established with the Adjust menu into one window. The window works like two separate windows. Any change you make in this window can occur while a test is running.

Prerequisite

You must set the error and underpeak levels with the Adjust Error Detectors and Adjust Underpeak Detectors windows before you can use the Control section of Display Detector Actions window.

Note You can make all the limit settings with this window or the Adjust Input Signals window.

Select the Limits radio button to display this window.

Any of the ten actions can be assigned to any detector (actions 1 - 4 are shown for the Upper Limit actions)

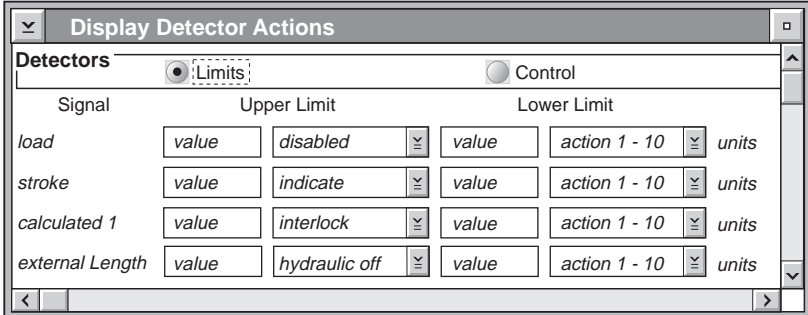

The screenshot shows the 'Display Detector Actions' window with the 'Limits' radio button selected. The window is divided into two main sections: 'Detectors' and 'Control'. The 'Detectors' section is active and contains a table with columns for 'Signal', 'Upper Limit', and 'Lower Limit'. The 'Control' section is inactive.

Signal	Upper Limit	Lower Limit
load	value [disabled] [v]	value [action 1 - 10] [v] units
stroke	value [indicate] [v]	value [action 1 - 10] [v] units
calculated 1	value [interlock] [v]	value [action 1 - 10] [v] units
external Length	value [hydraulic off] [v]	value [action 1 - 10] [v] units

Select the Control radio button to display this window.

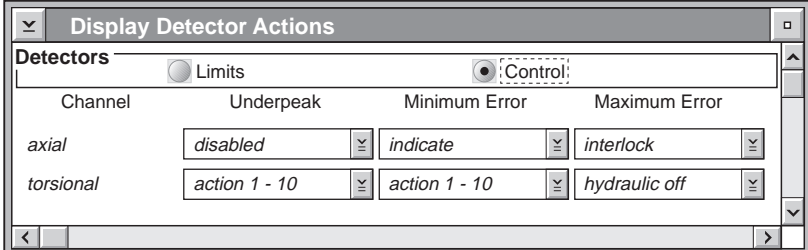

The screenshot shows the 'Display Detector Actions' window with the 'Control' radio button selected. The 'Control' section is active and contains a table with columns for 'Channel', 'Underpeak', 'Minimum Error', and 'Maximum Error'. The 'Limits' section is inactive.

Channel	Underpeak	Minimum Error	Maximum Error
axial	[disabled] [v]	[indicate] [v]	[interlock] [v]
torsional	[action 1 - 10] [v]	[action 1 - 10] [v]	[hydraulic off] [v]

SELECTION	FUNCTION
Detectors	Selects which detectors are displayed in the window. The Limits selection shows the input channel detectors. The Control selection shows the control channel detectors.
Limits	Shows the upper and lower limits (and actions) for all input signals.
Signals	Lists the names of the defined input signals. Pressing the signal button displays the Adjust Input Signals window.
Upper Limit Lower Limit	Shows the value of the limit and the selected action. Both the value and the action may be changed in this window.
Control	Shows the actions for the underpeak and error detectors for all the defined control channels
Underpeak	Selects an action for the underpeak detector.
Minimum Error Maximum Error	Selects an action for each error detector. The minimum error is usually set to indicate and the maximum error is set to stop the test.

Using the limit window

The limit window mode shows the current upper and lower limit settings for each input signal. You can change any limit value by typing in a new value in the entry field. You can also change the detector action.

For example, assume you did not know what values to use for a strain input channel. While the test is running, note the high and low output of the strain input signal (use the Display Input Signals window or set up a peak/valley meter). Once you determine the normal operating range for the input signal, you can decide the margin for limit values.

Using the control window

The control window mode shows the underpeak, minimum error, and maximum error detector action selections. You can change any action

For example, assume you had set the underpeak detector action to Interlock and that it is tripping too often. You may want to change the detector action to indicate so you can determine what is causing the underpeak detector problem.

Actions

An action determines what happens when the associated limit level is crossed. The following are the actions you can use:

- ◆ **Disabled** – turns the detector off.
 - ◆ **Indicate** – displays a message in the Fault Status window that the detector has been triggered.
 - ◆ **Hydraulics Off** – turns off the hydraulic pressure at the service manifold, displays a message in the Fault Status window and lights the Aux indicator on the LUCP.
 - ◆ **Interlock** – turns off the hydraulic pressure, generates an interlock signal, clamps the servovalve, and displays a message in the Fault Status window. You must correct the reason for the interlock and use the Reset button (located on the load unit control panel) to clear the interlock.
 - ◆ **Customer-defined** – these actions can be defined to ramp or hold the control channel output. These actions may also be identified with a customer-defined name or as Action 5 - 10.
-

30 Display Meters

Prerequisite You must define and enable each meter with the Edit Meters window before you can display the meters.

Use this window to monitor test related signals. The meter works like a digital meter

This menu and the buttons below it start, stop, and reset all of the meters.

This menu selects how the meters are arranged (vertically, horizontally, or in a box).

The mode can be:

- Timed
- Peak/Valley
- Span/Mean
- Max/Min

The parameters are determined by the selected mode.

The screenshot shows a window titled "Display Meters" with two tabs: "Controls" and "Alignment". Under "Controls", there are four icons: a square with "30", a circle with a dot, a circle with a horizontal line, and a square with a vertical line. Below these icons, the "Timed" mode is selected, showing "Slot 2" with a value of "4.8754" and "N", and "Undefined" with a value of "0.00000".

Types of meters

Each type of meter defines what information is displayed for a given input signal.

This waveform shows the type of data that can be displayed.

The peak/valley and span/mean modes update data each cycle.

The max/min (maximum and minimum) data mode monitors the entire waveform.

The timed data mode displays a signal value every second.

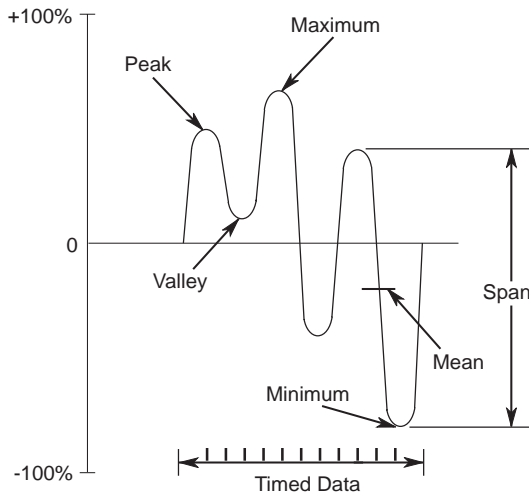

Tool bar

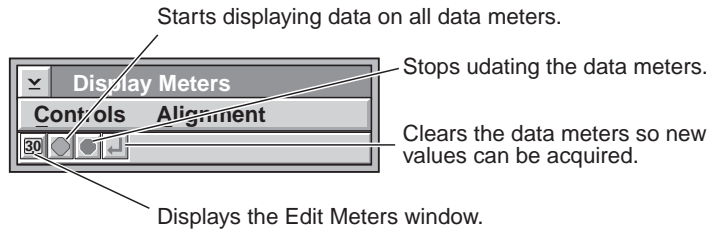

Control menu

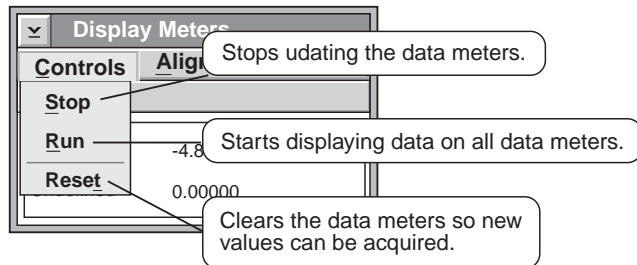

Alignment menu

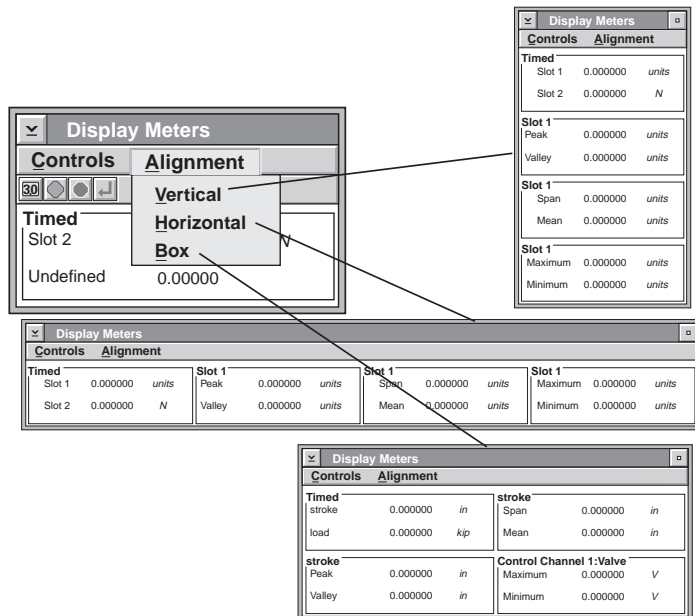

Display Menu



Display Scope

This window displays a graphic representation of up to two input signals.

- ◆ Each signal can be displayed with different colors.
- ◆ You can change the size of the window and the graph automatically sizes proportionately.

Prerequisites

You must define the scope with the Edit Scope window before you can use this window.

Use this window to monitor test related signals. The scope works like an oscilloscope.

See the Set Scroll Range window to see how to scale an axis.

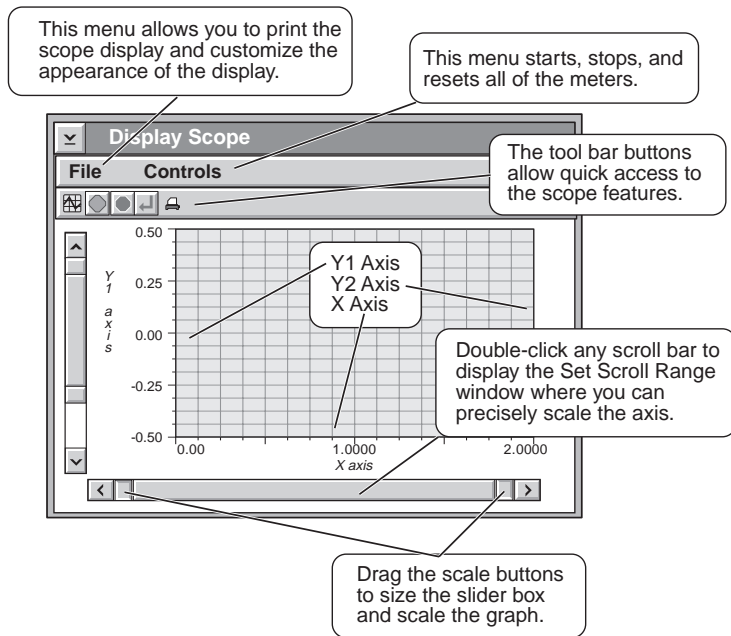

Scaling the axis

The slider box in each scroll bar has an extra set of buttons. These buttons can change the display range of the scope axis. *For example*, drag the upper button towards the center of the scroll bar. This reduces the size of the slide box and reduces the maximum value of the axis.

Tool bar

Press a button once to perform its task.

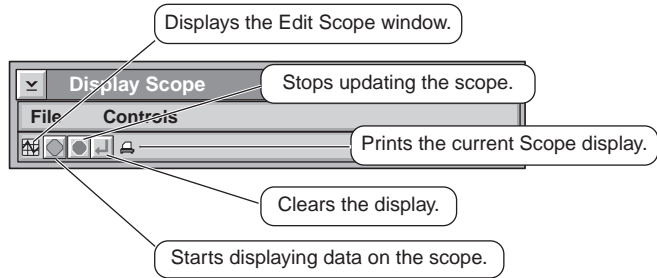

File menu.

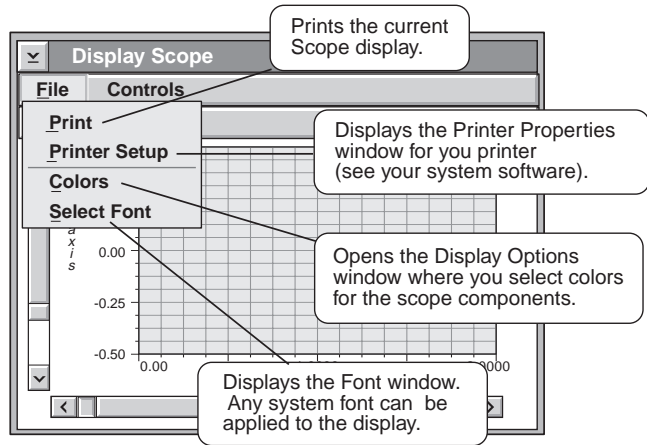

Control menu

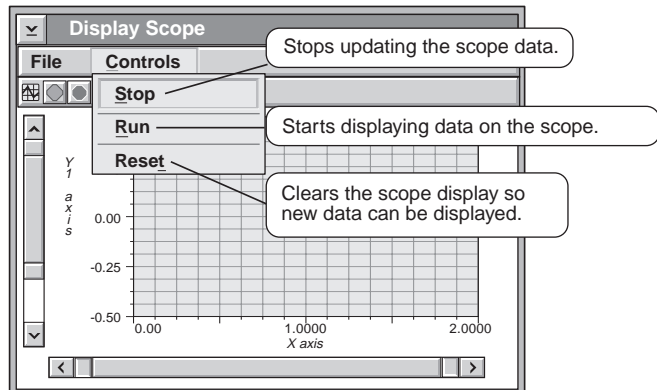

Set Scroll Range Window

Use this window to establish the adjustment range for one of the axis.

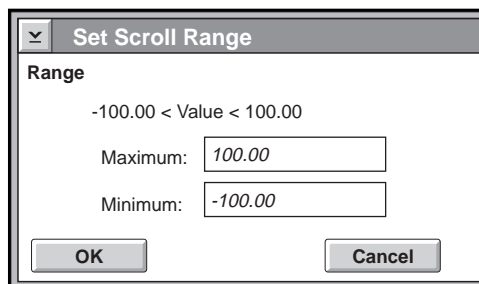

Note The default values are -100% (min.) and +100% (max.) full-scale for a signal and the time axis has a range of 0 to the trace time.

Using the window

The window displays the full-scale value of the selected input signal. You can change the maximum or minimum setting of the scroll bar to a value less than full-scale. The Max. and Min. parameters can be set to different levels. To change a scroll range value, type the new value in the entry field.

You cannot set the maximum range to a value less than the current output or the minimum range more than the current output.

For example, assume the Y1 axis is an LVDT input signal, its range is ± 5 mm, and you expect an LVDT output between 0 mm and 3 mm.

Setting the scroll bar range to a minimum of -0.5 mm and a maximum of 3.5 mm changes the size of the slider box.

This represents the scale of the graph. You could move the slider box to the top of the scroll bar and the graph would be scaled to show from 1 to 5 mm.

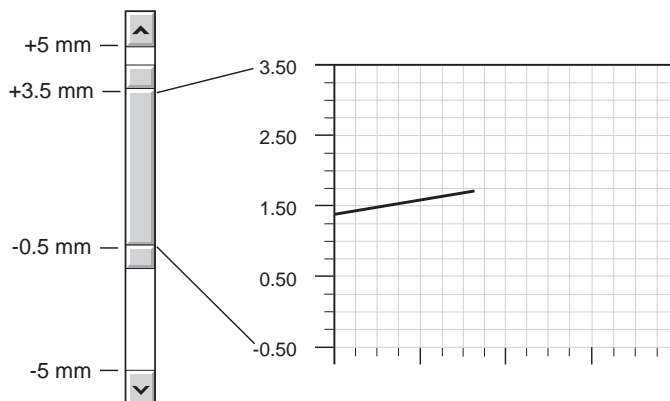

Scope Display Options Window

Use the this window to select the colors of the digital scope display.

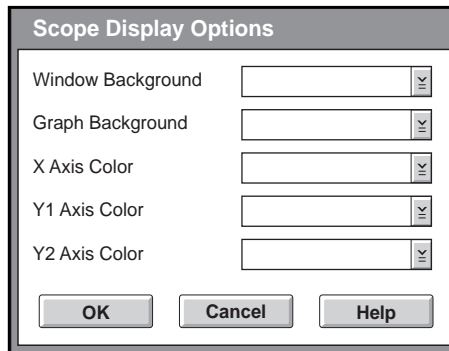

Using the window

The Scope Display Options window shows the current settings of the scope display colors.

Pressing the list icon of any parameter lists the available colors. Select the color of your choice for each parameter. Press the OK button to return to the Digital Scope window and view the effect of your color choices.

Colors

The following is a list of colors you can select for any of the display parameters.

- ◆ Black
- ◆ Dark Gray
- ◆ Red
- ◆ White
- ◆ Light Gray
- ◆ Green
- ◆ Blue
- ◆ Magenta
- ◆ Gray
- ◆ Cyan
- ◆ Yellow



TestStarTM II

Control System

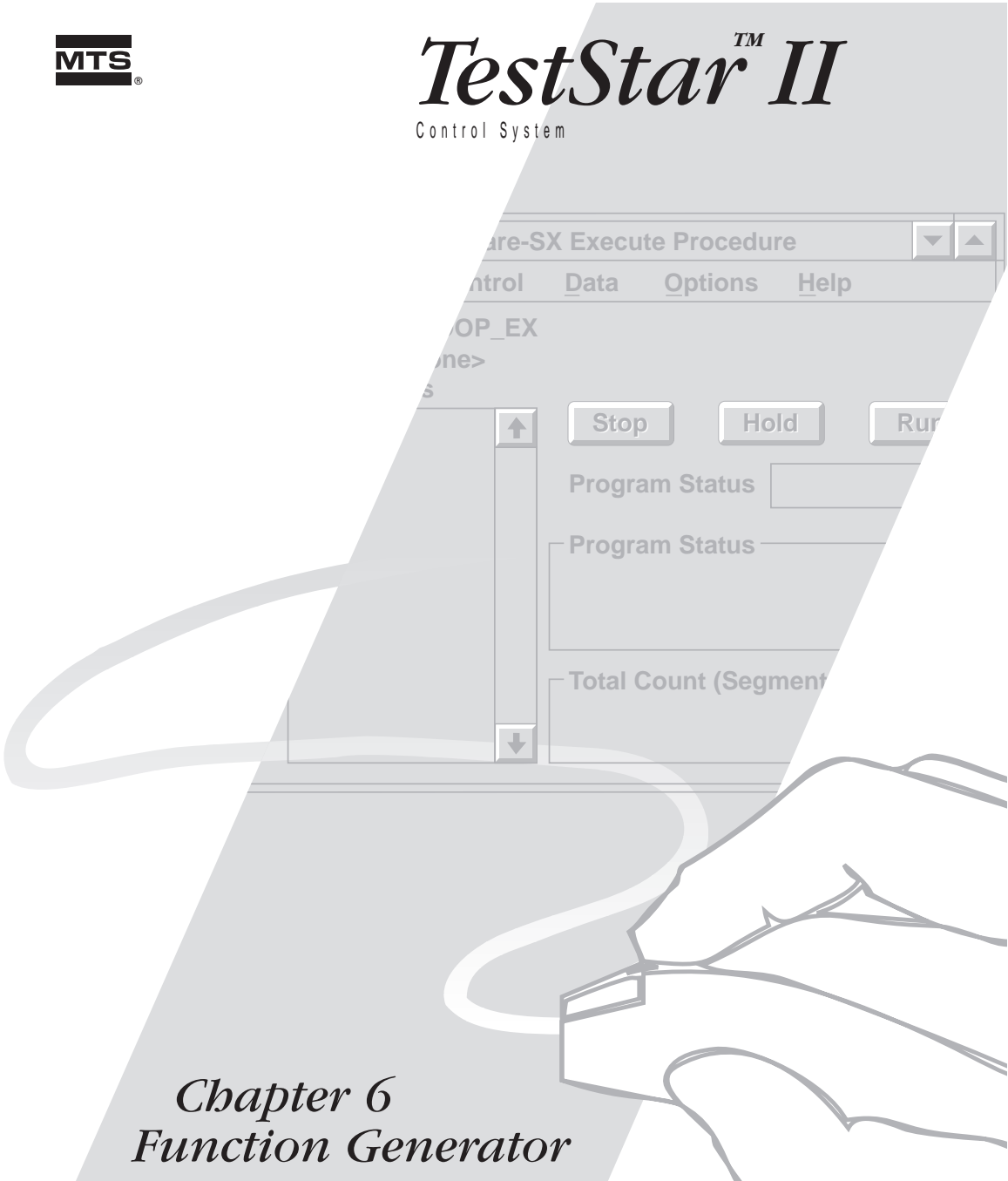

Chapter 6 Function Generator

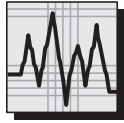

Function Generator

The main window, titled "Function Generator", features a menu bar with "Define" and "Help". Below the menu bar are three buttons: "Command...", "Count...", and "Home...". To the right of these buttons are "Hold", "Run", and "Home" buttons. The main area contains several controls: a "Mean" button with a "units" input field, a scroll bar, an "Amplitude" button with a "units" input field, a scroll bar, a "Frequency" button with a "Hz" input field, a scroll bar, and an "Enable Compensator" checkbox. A "Definition" pane is visible on the right side of the main window.

Overlaid dialog boxes include:

- Command Menu Options**: Contains "Control channel:" and "Control mode:" fields, each with a scroll bar and a double arrow button.
- Count Menu Option**: Contains "Units:" and "Preset Count" fields, a radio button for "ON" (selected) and "OFF", and another "Preset Count" field.
- Home Menu Option**: Contains "Control Mode:", "Endlevel:", and "Time:" fields, each with a scroll bar and a double arrow button. It includes "OK", "Cancel", and "Help" buttons.
- Set Scroll Range for: Frequency**: Contains "Min -" and "Max -" input fields with "Hz" units and an "OK" button.
- Set Scroll Range for: Amplitude**: Contains "Min -" and "Max -" input fields with "units" units and an "OK" button.
- Set Scroll Range for: Mean**: Contains "Min -" and "Max -" input fields with "units" units, and "OK", "Cancel", and "Help" buttons.

Arrows indicate the following interactions: "Command..." points to "Command Menu Options"; "Count..." points to "Count Menu Option"; "Home..." points to "Home Menu Option"; "Mean" points to "Set Scroll Range for: Mean"; "Amplitude" points to "Set Scroll Range for: Amplitude"; and "Frequency" points to "Set Scroll Range for: Frequency".

Chapter 6

Function Generator

The function generator is a program that generates a waveform to command the servo control loop.

Contents

Function Generator Window	206
Set Mean Scroll Range	211
Set Amplitude Scroll Range	212
Set Frequency Scroll Range	213
Function Generator Window	206
Command Menu Options Window	214
Count Menu Option Window	220
Home Menu Option Window	222
Designing a Test Program	224

Prerequisites

You must have the following defined before you can use the function generator.

- ◆ input signals
- ◆ control channels
- ◆ control modes

You should also have a TestStar configuration file set up for a test before you actually run the function generator.

Function Generator Window

Prerequisite

You must define the input signals, control channels and control modes to use this window. You should also set up the sensors with the Adjust Input Signals window before running the function generator.

Use this window to generate a wave form to command the servo control loop.

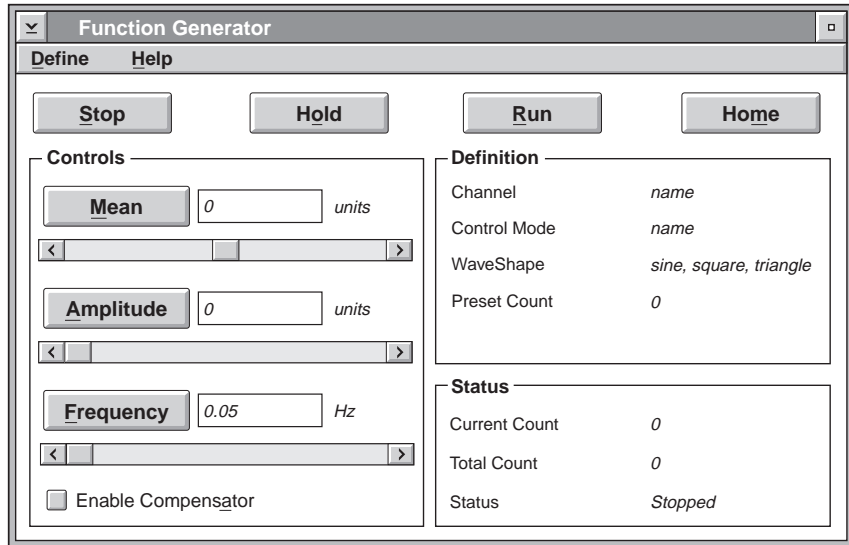

CONTROL	FUNCTION
Define	Defines the servo loop command, sets up the counter, and establishes the home function.
Stop	Ends the test and causes the program command to return to the mean level.
Hold	Suspends the program command until you press the Run or Stop button.
Run	Starts the program command described in the Definition area.
Home	Executes a ramp you define from the ending output to a predefined output. You can define the Home button to return the actuator to its starting position. Select Home in the Define menu to define the ramp.
Mean	Adjusts the mean level of the command. Pressing the Mean button displays a Set Scroll Range window where you can change the maximum and minimum values of the Mean adjustment.
Amplitude	Adjusts the peak-to-peak amplitude of the command. Pressing the Amplitude button displays a Set Scroll Range window where you can change the maximum value of the Amplitude adjustment.
Frequency	Adjusts the frequency of the command. Pressing the Frequency button displays a Set Scroll Range window where you can change the maximum value of the Frequency adjustment.
Enable Compensator	Enables the compensator function selected in the Command Menu Options window.
<i>units</i>	Displays the units of the selected control mode.
Definition	Shows the current command definition as established with the Command selection in the Define menu.
Status	Shows the status of the test and counter.

Using the window

The function generator defines a program command to control the hydraulic actuator. Before you run a waveform, you should complete any necessary functions in the TestStar Adjust menu.

- ◆ Use the Define menu to create a waveform.
- ◆ Use Mean, Amplitude, and Frequency controls to parameterize the waveform.
- ◆ Use the Stop/Hold/Run/Home buttons to control the waveform.
- ◆ See *Designing a Test Program* on page 224 for detailed instructions.

Mean level

The Mean level control introduces an offset that references the command to a level other than zero. The mean level value uses the units selected in the command definition. Adjust the Mean level control within \pm full-scale of the selected control mode.

For example: assume you want to run a 2 cm sine waveform between 1.5 and 3.5 cm. Adjust the Mean level control for 2.5 cm.

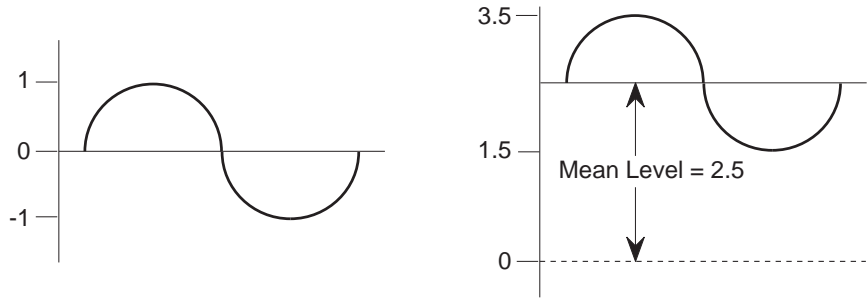

You can adjust the mean level while the program is running.

The mean level changes when the current cycle reaches an end level.

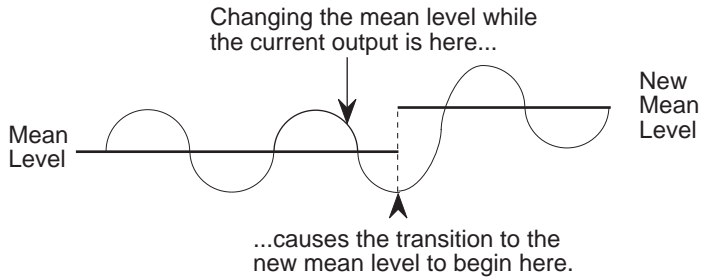

You can change the range of the control by pressing the Mean button and entering different minimum and maximum settings for the control.

Amplitude

The Amplitude control establishes the peak-to-peak span of the command. The amplitude value uses the units selected in the command definition. You can adjust the Amplitude control within the span of the selected range.

For example: assume you want to run a sine wave between +1 cm and -1 cm. Set the amplitude to 2 cm.

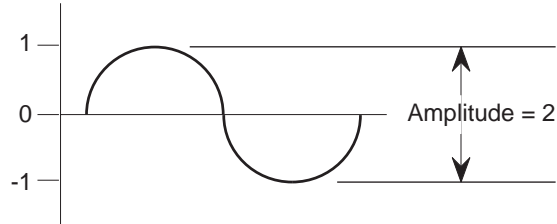

You can adjust the amplitude level while the program is running.

The amplitude changes when the current cycle reaches an end level.

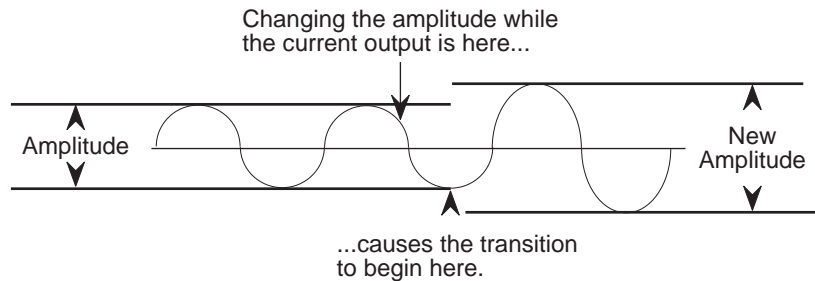

Pressing the Amplitude button allows you to change the range of the control by entering a different maximum value for the control.

Frequency

The Frequency control sets the number of waveshape cycles per second. The frequency value is expressed in hertz. You can adjust the Frequency control between 0.01 and 300 Hz.

You can change the frequency while the program is running.

The frequency changes when the current cycle reaches an end level.

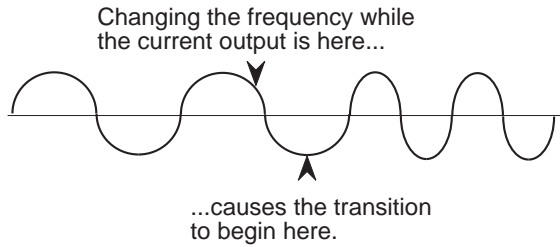

Pressing the Frequency button allows you to change the range of the control (the default setting is 10 Hz) by entering a different maximum frequency for the control.

Status

The Status display shows the current count, total count, and test control status. The counter display updates each time the program command definition completes one cycle. When the current count equals the preset count, the current count automatically resets to zero. To reset the total count, enter zero in the Count Menu Options window.

The test control status displays the following:

STATUS	CONDITION
Ramping	While the program ramps to the mean level.
Running	While the program is working.
Holding	After pressing the Hold button.
Stopping	After pressing the Stop button and while the program ramps to the mean level.
Stopped	After pressing the Stop button, and after the program reaches the mean level or, after the Home ramp is complete.
Homing	While the program ramps to the home level.

Set Mean Scroll Range

Setting the scroll range of the Mean adjustment ensures the control is within a safe range. Reducing the scroll range also increases the resolution of the control adjustment.

The Set Scroll Range Mean window changes the range of the Mean adjustment.

Using the window

The window displays the full-scale value of the selected control mode range. You can change the maximum and/or minimum setting of the Mean control to a value less than full-scale. Set the Max and Min limits to different levels. You cannot set the maximum range to a value less than the current Mean setting or the minimum range more than the current Mean setting.

To change a scroll range value, type the new value in the entry field.

For example, assume the control mode range is ± 3 cm.



With the Max and Min values set to +3 cm and -3 cm, the zero reference is centered.



With the Max and Min values set to +3 cm and -1.5 cm, the zero reference is offset.

Changing the range re-scales the control setting.



The Max and Min values are +3 cm and -3 cm and the Mean control is 2 cm.



Changing the Max setting to +2 cm causes the Mean control to reach the maximum range

Set Amplitude Scroll Range

Setting the scroll range of the Amplitude adjustment ensure the control is within a safe range. Reducing the scroll range also increases the resolution of the control adjustment.

The Set Scroll Range Amplitude window reduces the range of the amplitude adjustment.

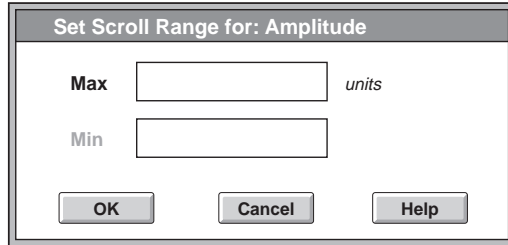

Using the window

The window displays the full-scale value of the selected control mode range. The default value represents the span between \pm full-scale. You can change the maximum setting of the Amplitude control to a value less than full-scale, but not below the current amplitude setting. The maximum setting cannot be set below 0.

To change the scroll range value, type the new value in the entry field.

For example, assume the control mode range is ± 3 cm. The default scroll range is 6 cm. Changing the range to 2 cm ensures the test cannot exceed ± 2 cm.

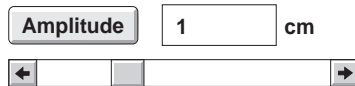

The Amplitude control is 1 cm with the scroll range of 3 cm

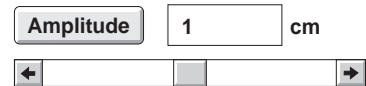

Changing the scroll range to 2 cm also changes the 1 cm reference.

Set Frequency Scroll Range

The Set Scroll Range Frequency window sets the maximum Frequency adjustment value.

Setting the scroll range of the Frequency adjustment ensures the control is within the capabilities of your equipment. Reducing the scroll range also increases the resolution of the control adjustment.

Using the window

The window displays the maximum frequency of the adjustment. The range of the Frequency control setting is 0.01 and 300 Hz. The default setting is 10 Hz.

To change the scroll range value, type the new value in the entry field.

For example, assume the default value is 10 Hz. Changing the range value to 20 Hz increases the range of the Frequency adjustment.



The Frequency control is set to 5 Hz with the scroll range set to 10 Hz



Changing the scroll range to 20 Hz also changes the 5 Hz reference.

Command Menu Options Window

Prerequisite



You must define the input signals, control channels and control modes to use this window.

Use this window to define the servo loop command.

The screenshot shows a dialog box titled "Command Menu Options". It contains several input fields and a checkbox:

- Control channel:** A text input field with a small icon on the right.
- Control mode:** A text input field with a small icon on the right.
- Units:** A text input field with a small icon on the right.
- Initial ramp rate:** Two text input fields, each with a small icon on the right.
- Ampl. ramp time:** Two text input fields, each with a small icon on the right.
- Waveshape:** A text input field containing the text "sine, square, triangle" and a small icon on the right.
- Compensation:** A text input field containing the text "peak/valley/PAC" and a small icon on the right.
- Waveshape order:** A checkbox labeled "Inverted".

At the bottom of the dialog box are three buttons: "OK", "Cancel", and "Help".

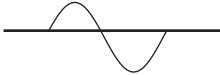
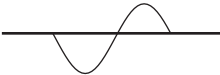
CONTROL	FUNCTION
Control channel	Selects the control channel for the test command. For a single-channel system, one choice is available (typically called axial).
Control mode	Selects the control mode for the test command.
Units	Shows the current units of the control mode. Select the units you want to use for the Initial Ramp Rate, the Mean adjustment, and the Amplitude adjustment.
Initial ramp rate	Specifies the ramp rate from the starting level of the actuator to the mean level setting when the test begins. The starting position of the actuator is usually the zero reference of the program command. The ramp rate value represents units per second.
Ampl. ramp time	Specifies the amount of time the program amplitude ramps from zero to full-scale (and vice versa). This is only available when using an external command source.
Waveshape	<p>Specifies the type of waveform. Three waveforms are available:</p> <div style="display: flex; justify-content: space-around; align-items: center; text-align: center;"> <div data-bbox="629 753 682 805"></div> <div data-bbox="841 753 893 805"></div> <div data-bbox="1058 753 1125 805"></div> </div> <p>Sine Square Triangle</p> <p>Select the waveshape you want to use.</p>
Compensator	<p>Specifies if a compensation circuit is used.</p> <ul style="list-style-type: none"> • Peak/Valley provides amplitude/mean control. • PAC provides phase and amplitude control
Waveshape order	<p>Determines if the waveshape starts positive or negative.</p> <div style="display: flex; justify-content: space-around; align-items: center; text-align: center;"> <div data-bbox="644 1130 862 1204"></div> <div data-bbox="905 1130 1123 1204"></div> </div> <p>Normal Order Inverted Order</p>

How it works

After you define a function generator program and press the Run button, the following occurs:

- ◆ The initial ramp executes to achieve the mean level setting.
- ◆ The waveshape order selection applies the waveshape from the mean level to the amplitude end level.
- ◆ The waveshape cycles according to the requirements of the amplitude, frequency, and preset count. (Cycles count from one end level to the next end level of the same value.)
- ◆ When the cycle count is complete, or the Stop button is pressed, the waveshape continues from the amplitude end level to the mean level.
- ◆ The Home button executes a ramp to the home position.

For example, assume the function generator is set up with these characteristics:

PARAMETER	SETTING
Command	
Control Mode	length
Units	cm
Waveshape	sine
Waveshape Order	inverted
Initial Ramp Rate	1 cm/sec
Preset Count	2 cycles

PARAMETER	SETTING
Home Ramp	
Control Mode	length
End Level	0 cm
Time	1 sec
Frequency	1.5 Hz
Mean Level	-1.5 cm
Amplitude	1 cm

The figure shows the components of a program command.

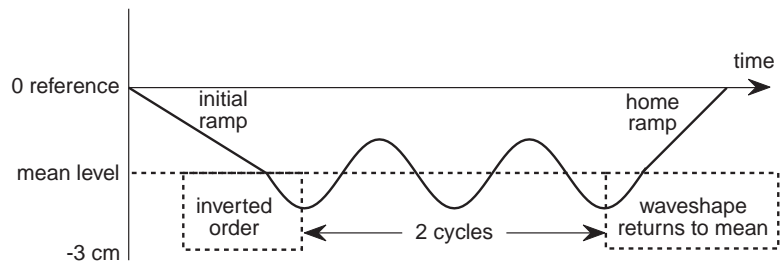

Continued...

How it works
(continued)

Another example, assume the function generator is set up with these characteristics:

PARAMETER	SETTING
Command	
Control Mode	length
Units	cm
Waveshape	sine
Waveshape Order	Normal
Initial Ramp Rate	1 cm/sec
Preset Count	Off

PARAMETER	SETTING
Home Ramp	
Control Mode	length
End Level	0 cm
Time	1 sec
Frequency	1 Hz
Mean Level	-1 cm
Amplitude	4 cm

Pressing the Stop button causes the waveform to end at the mean level.

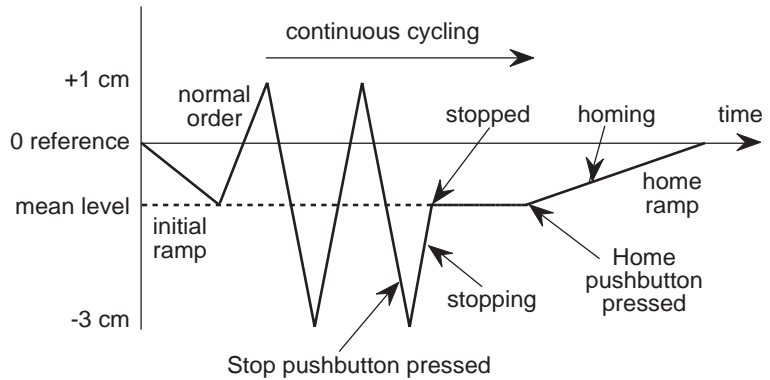

Using an external command source

The function generator can be used in conjunction with an external command source. Before you can use an external command source, the following must be true:

- ◆ The external command source must be defined. See Chapter 10 in the Installation manual for complete instructions to define an external command source.
- ◆ A temporary sensor must be defined for the external command input channel. See Chapter 10 in the Installation manual.
- ◆ The external command control mode must be defined. See PIDF Control Mode in Chapter 3.
- ◆ The external command control mode must be selected with the Command Menu Options window.

The following characteristics apply when an external command source is used with the function generator.

- ◆ The Waveshape selection is disabled because the external command source provides that function.
- ◆ The Frequency adjustment is disabled.
- ◆ The Amplitude adjustment is scaled for percentage of full-scale.
- ◆ The Amplitude ramp time specification is enabled.
- ◆ When you press the Run button, the function generator ramps the external command amplitude to full-scale.
- ◆ When you press the Hold button, the function generator selects a non-external command control mode to hold the actuator position.
- ◆ When you press the Stop button, the function generator ramps the external command amplitude to zero.

See Chapter 10 in the Installation manual for complete instructions to use an external command source.

Amplitude Ramp Time

The Amplitude Ramp Time can only be used with an external command source. It allows you to slowly apply the program command to the specimen when the program starts. It also ramps the program amplitude down when the Stop button is pressed.

This feature prevents sudden actuator movement when the external command starts.

A command begins with an amplitude of zero and gradually increases until the programmed amplitude is reached.

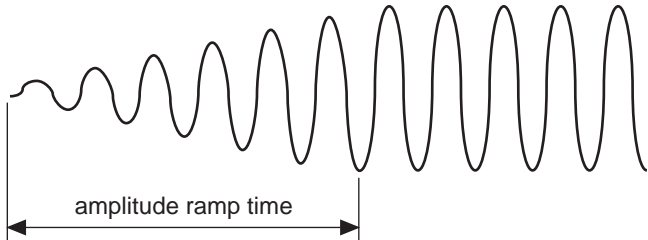

Compensators

Compensators compare the sensor feedback to the test command to determine if the command signal is actually being properly applied to the specimen. Compensators can provide specific types of correction to ensure the command is properly applied to the specimen.

Note *The convergence rate (Adjust Compensators window) determine how fast the compensator works.*

Peak/Valley

This compensator detects any amplitude roll-off and any difference in the mean level. Amplitude roll-off refers to the tendency of amplitudes measured by the sensors to be less than the desired amplitudes. This can also cause a mean level difference.

Enabling the peak/valley compensation causes the program to adjust the servovalve command signal until the programmed amplitude is achieved and the mean level is maintained. It takes a few cycles to start amplitude/mean control and a few cycles to end it.

PAC

PAC only works with sine waves. This compensator detects any amplitude roll-off and any phase lag. Amplitude roll-off refers to the tendency of amplitudes measured by the sensors to be less than the desired amplitudes. Phase lag refers to the lag between the command producing a physical event and the measured response from a sensor.

Enabling PAC causes the program to adjust the servovalve command signal until the programmed amplitude is achieved, and the phase lag is removed.

Count Menu Option Window

Use this window to configure the counter to cycle continuously or to stop the function generator after a preset number of cycles.

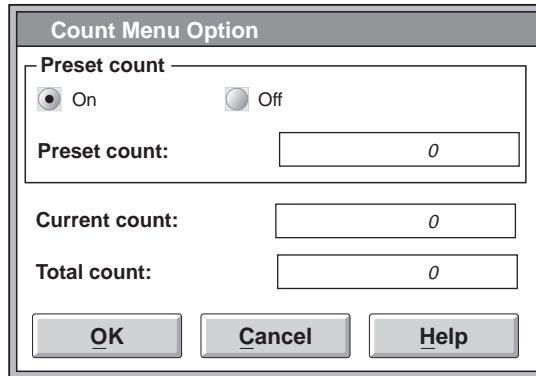

CONTROL	FUNCTION
Preset Count	Turning the Preset Count Off causes continuous cycling. Turning the Preset Count On sets the counter to the value entered in the Preset Count entry field. A preset count of 0 causes the waveform to execute a half cycle (a single segment).
Current Count	Displays the current count. When the current count equals the preset count, the waveform stops. Type 0 to clear the current count.
Total Count	Displays the total count. Use the total counter to keep a cumulative count. Type 0 to clear the total count.

Preset count

After enabling the Preset Count, type the number of cycles you want. Each cycle of the waveshape updates the Current Count and Total Count displays. When the current count equals the preset count, the function generator stops.

You may want to use the counter to stop the waveform periodically to record data or to change the servo loop command.

For example, assume you want to cycle a specimen 100 times and acquire data (such as the maximum and minimum values) once every 10 cycles. Perform the following:

1. Turn the Preset Counter On.
2. Enter 10 in the Preset Count entry field.
3. Run the function generator.
4. When the function generator stops, record the required data. The Current Count automatically resets to 0.
5. Repeat steps 3 and 4 until the total count equals 100.

How it works

Cycles count from one end level to the next end level of the same value. The amplitude and mean level settings define two end levels of a cycle. A cycle consists of two waveshape segments.

The waveshape order begins the waveform from the mean level to an end level. When the waveform cycle ends, it continues from the end level to the mean level.

Two components are added to a cyclic waveform. The waveshape order starts the waveform and return to mean ends the waveform.

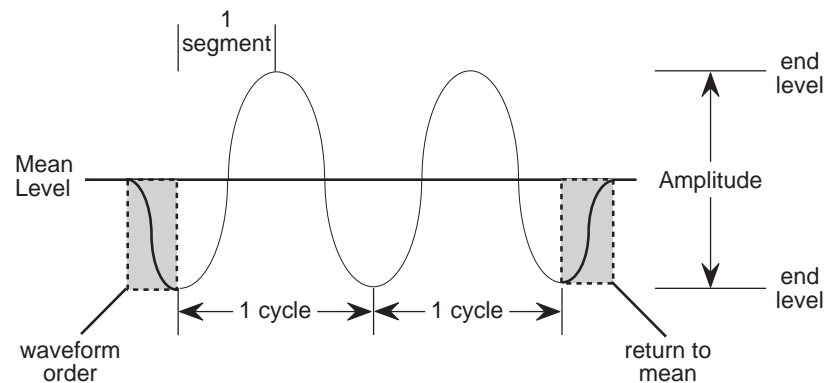

Home Menu Option Window

The Home Menu Option window defines a ramp for the Function Generator Home button. The Home option returns the actuator to a specific position at the end of a test (typically the starting position or zero reference).

Use this window to define the Function Generator Home button.

CONTROL

FUNCTION

Control Mode

Selects the control mode for the Home button.

End level

Specifies the end level the control mode achieves when the Home button is pressed. Select the units you want to use for the end level.

Time

Specifies the amount of time the ramp executes. The time value is seconds.

How it works

The Home Menu Option window defines a mode that is assigned to the Home button. Pressing the Home button causes the servo command to ramp from the current servo control setting to the defined end level. The Home function can be defined as a ramp in a test or, to return the actuator to its starting position at the end of a test.

The home ramp does not have a ramp rate. The ramp executes from any starting position to the defined end level in the amount of time specified.

Pressing the Home button causes the home ramp to begin immediately.

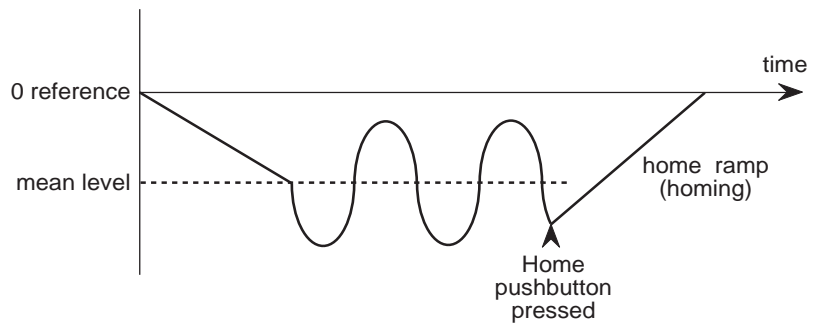

A common use of the Home function is to return the actuator to its starting position (typically the zero reference) at the end of a test. This is sometimes called return to zero. One way to accomplish this is as follows:

1. Select a displacement (length) control mode.
2. Enter an end level of 0 (zero) and select the units to define the end level.
3. Enter a time in seconds (such as 2 seconds).

Pressing the Home button causes the actuator to achieve a zero displacement in 2 seconds.

Designing a Test Program

This procedure describes how to define a waveform with the Function Generator program.

Note This procedure defines a tuning waveform for a force transducer. The values in this procedure produce a 2500 N waveform for a system with a force train rating of 25 kN.

1. Determine your test requirements 224
2. Open the Function Generator program 225
3. Define the command waveform 226
4. Define the counter 226
5. Define the home ramp 227
6. Parameterize the program command 227
7. Run the program command 228

Step 1 Determine your test requirements

The example in this section will create a cyclic triangle waveform that can be used to tune a force transducer. A common tuning command is 10% of full-scale cycling at 1 Hz.

- ◆ Determine the components of the waveform. Now you can establish the function generator settings using the Mean, Amplitude, and Frequency controls along with each of the Define menu options.

Sketch the waveform and identify significant information

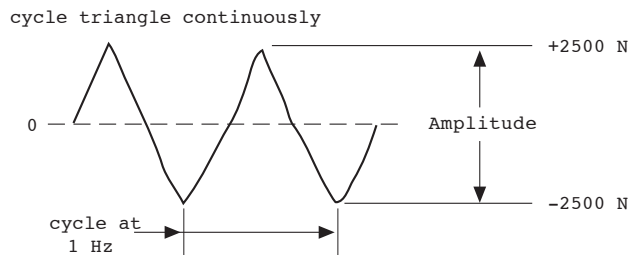

Step 2 Open the Function Generator program

- A Double-click the MTS-TSII icon on the OS/2 desktop.
- B Double-click the Function Generator icon.
- C You may need to login to open the Function Generator program.
Enter your user name and password in the MTS Login window.

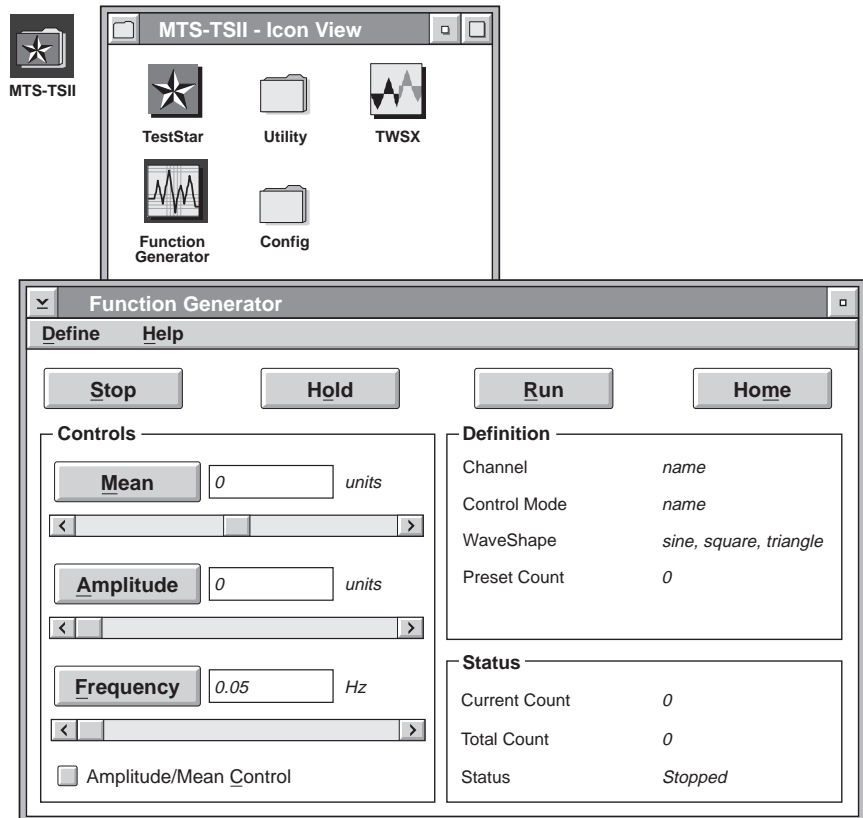

Step 3 Define the command waveform

- A Select Command in the Define menu.
- B Complete the Command Menu Options window as shown below.

This window defines the triangle waveform and the control mode.

The name of your force control mode may be different.

The information in this window appears in the Definition area of the Function Generator window.

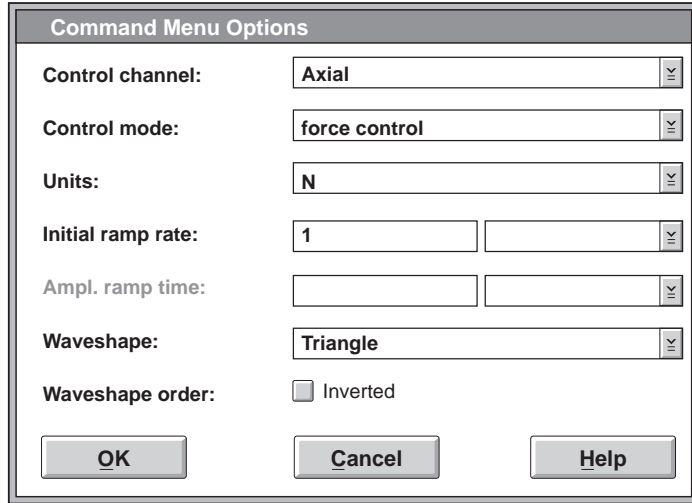

Step 4 Define the counter

- A Select Counter in the Define menu.
- B Turn the Preset Count **Off** to cycle continuously.

This window sets up a continuous cycle.

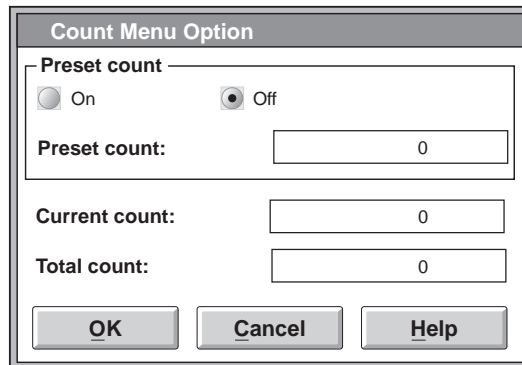

Step 5 Define the home ramp

- A Select Home in the Define menu.
- B Complete the Home Menu Option window to define the Home button ramp.

The control mode shown may have a different name than the one you may use.

A typical home ramp returns the actuator to its starting position.

Home Menu Option

Control mode: force control

End level: 0 N

Time: 1 sec

OK Cancel Help

Step 6 Parameterize the program command

Set the Mean, Amplitude, and Frequency controls as shown to parameterize the waveform.

Function Generator

Define Help

Stop Hold Run Home

Controls

Mean 0 N

Amplitude 2500 N

Frequency 1 Hz

Amplitude/Mean Control

Definition

Channel	Axial
Control Mode	force control
WaveShape	triangle
Preset Count	0

Status

Current Count	0
Total Count	0
Status	Stopped

Step 7 Run the program command

Before you run the test command, install a specimen. You should also have a TestStar configuration defined for this test command (limits, detectors, etc.).

- A** Press the Run button to start the program command.

While the test is running you can press the Hold button to suspend the test. Press the Run button to resume the program command.

Otherwise perform any tasks you need to do. In this case, you would tune the force control mode.

- B** Press the Stop button to end the command. At this point you could change the command definition and run the new program command.
 - C** Press the Home button to return the actuator to the Home position.
-



TestStarTM II

Control System

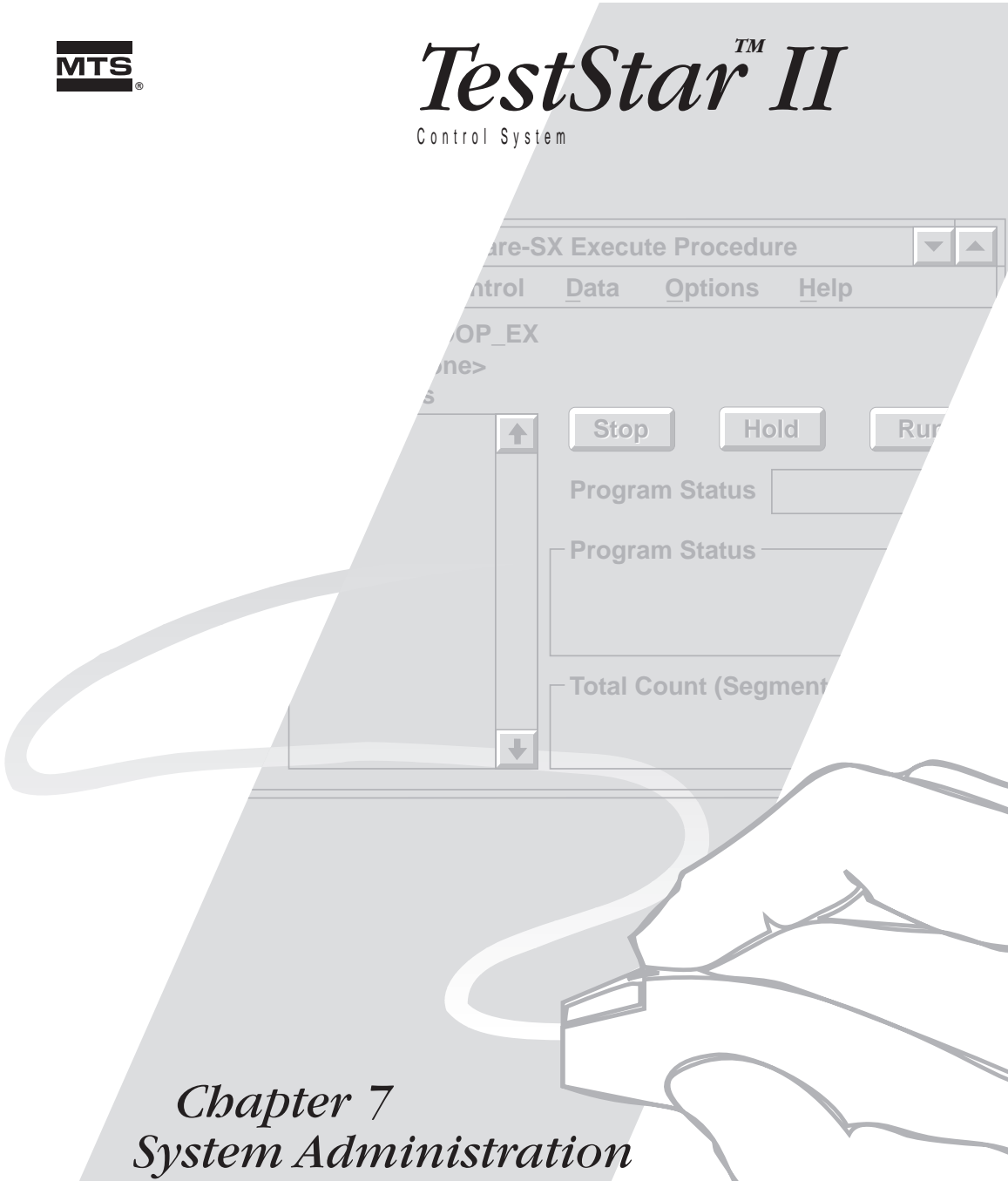

Chapter 7 System Administration



System Administration

System Administration

File Define

Users Applications

list of applications installed

Add Delete Edit Help

System Administration

File Define

Users

list of defined users

Add Delete Edit Help

System Administration

File Define

Applications

list of applications installed

Add Delete Edit Help

New User

Username:

Password:

Last name:

Middle initial:

First name:

Configuration:

Unit Assignment:

Add

Edit User user name

Username:

Password:

Last name:

Middle initial:

First name:

Configuration:

Unit Assignment:

Change Cancel Help

New Application

Program title:

Program file name:

Add Cancel Help

Edit Application application name

Program title:

Program file name:

Change Cancel Help

Application Access

name of user

list of defined applications

OK Cancel Help

User Access

name of application

list of defined users

OK Cancel Help

Chapter 7

System Administration

When you log into TestStar, you must enter a user name and a password. The System Administration program defines user names and their passwords; the program also allows access to TestStar and its programs.

Contents	System Administration Window	233
	New/Edit User Window	235
	Application Access Window	237
	New/Edit Application Window	238
	User Access Window	239
	Creating a New User	240

What you need to know

You need to know the following to use the System Administrator:

- ◆ How do you want to use user names?
 - ◆ What are the file names of the TestStar configurations?
 - ◆ What to do if you cannot log onto TestStar.
-

What is a user name?

A user name can represent people or test configurations. Consider how you expect to use the TestStar system so you can determine how to use user names.

for people

For example, assume you have several people using TestStar that run specific tests. In this case you may want to assign user names that represent the individuals. Assign the following:

- ◆ A user name to identify the individual.
- ◆ A unique password for each individual.

Continued...

What is a user name? (...continued)

- ◆ A configuration file that the individual is most likely to use (other configurations can be opened once TestStar is started).
- ◆ The TestStar programs that the individual needs to use (such as the Function Generator or TestWare-SX).

for tests

For example, assume you have several competent people using TestStar to run many different types of tests. In this case you may want to assign user names that represent specific tests. Assign the following:

- ◆ A user name to identify the specific test.
- ◆ A password —one password for all user names is easier to remember (assuming all operators are competent).
- ◆ A configuration file that the test requires.
- ◆ The appropriate TestStar programs that the operator needs to access for the test (such as the Function Generator, TestWare-SX, Sensor Calibration, etc.).

If you can't log on

It can happen. You may have forgotten your user name or password, or your user name could have been deleted. TestStar includes a default user name and password so you can start TestStar the first time.

The default user name is **MTS** and its password is also **MTS**.

Unless your site has no security concerns, the MTS user name should be deleted after you have created additional users. Any unauthorized person attempting to gain access to the system would surely try this entry first.

CAUTION

Deleting the MTS user name without creating another user name will require the TestStar software to be reinstalled.

Be sure you create a user name that has full access to the TestStar programs.

System Administration Window

Use the System Administration window to add users and which applications they can access.

The Define menu configures the window to edit users or applications.

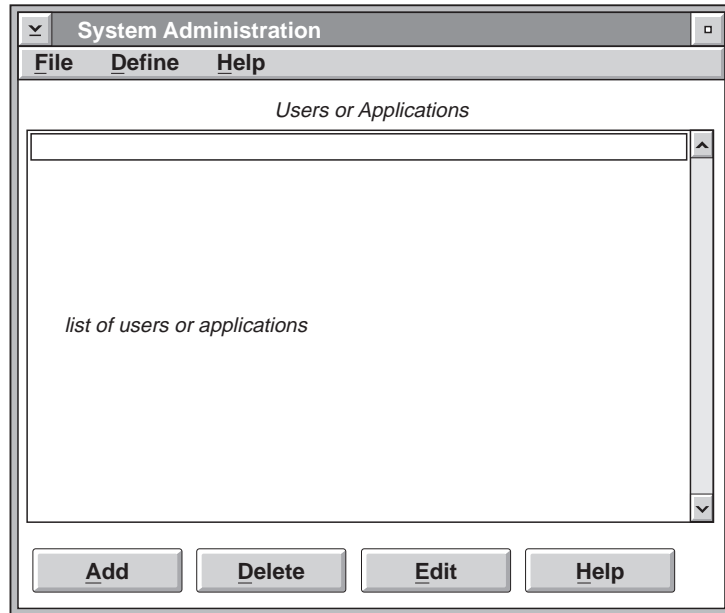

CONTROL	FUNCTION
File Menu	Exits the System Administration window and returns you to the TestStar window.
Define Menu	Configures the window for to edit users or applications.
Add	Adds a new user or application to the list shown. Displays the New User or New Application window where you can define a new user or application.
Delete	Removes the selected user or application from the list. Select an item from the list. Pressing the Delete button displays a dialog box that asks you to acknowledge your action.
Edit	Changes the information that defines a user or application. Displays the Edit User or Edit Application window for the selected item.

Users Users are names representing individuals and their access to TestStar applications. A user ID and a password define each user. Optional information can include the individual's full name.

When you log onto TestStar, you must enter a user name and a password. You can use upper- or lower-case characters for the user name and password.

Applications When you install an application, you can assign which users can have access to the application. Applications are programs such as the Function Generator, TestWare-SX, or the sensor calibration program.

Adding and editing The Add and Edit buttons work the same for users and applications.

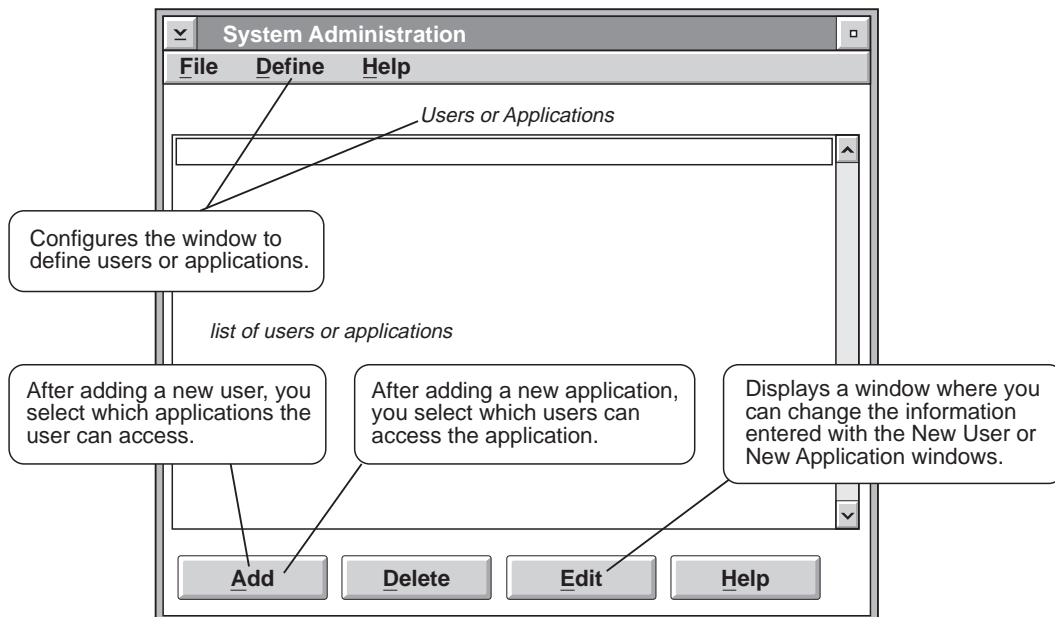

Press the Add button to define a new user or application. Select a user name or application title before pressing the Edit button to change user or application definition.

New/Edit User Window

The New User and Edit User windows are the same.

Use this window to define a new user or edit an existing user.

Completing this window displays the Application Access window.

CONTROL	FUNCTION
Username	The Username represents an individual's access to selected TestStar applications. Each individual must enter a Username when logging onto TestStar. This is a required parameter.
Password	A password is linked to each Username. Each individual must enter a password when logging on to TestStar (after entering a Username). This is a required parameter.
Last name, Middle initial, First name	These are optional parameters. You can label a Username with the individual's proper name. These are provided in the event you forget who is assigned to a given Username.
Configuration	Selects the TestStar configuration file that opens when you log on. Enter the complete path and filename in the entry field or enter none if you don't know the path (you can edit it latter). This is a required parameter.
Unit Assignment	Selects a set of default units that are used for the initial settings of the various TestStar and TestWare parameters. This is a required parameter.

How it works

When you log onto TestStar you enter your user name and password. TestStar recognizes only the names and passwords entered with the New User window or the Edit User window.

A configuration file and the unit assignment set open with TestStar with all the settings that were established during a previous session. After you add or edit a user, select which applications the user name can access.

Configuration file

A TestStar configuration file assigns values and selections to the parameters in each TestStar window. Each user name opens a TestStar configuration file.

Each TestStar configuration file is designed for a specific test. If you use configuration files correctly, you will have a configuration file for each test you run. You need to know the names of the configuration files and what they were designed for. You can always select a different TestStar configuration file after you log onto TestStar.

Note *TestStar configuration files can be located in any computer directory (see the Save As window in the File menu of the main TestStar window).*

If you do not change the default settings when you save a configuration, the file should be located in the DB directory within the TestStar directory. Use the following form to type the configuration entry field (where filename is the name of your file and TCC is the extension).

C:\TS2\config\filename.TCC

Unit assignment

The unit assignment set contains a selection of preferred units for each dimension. If you have not created a set of preferred units, select one of the predefined sets. The preferred set of units is used as the initial selections for the TestStar parameter values. The unit assignment for any parameter can be changed after you log onto TestStar.

For example, you may prefer a set of units that automatically selects millimeters instead of inches for all length parameter values. By using a preferred set of units, you will not need to select units for every TestStar parameter—only those you want to change.

Application Access Window

This window shows the user name and lists all the applications.

Use this window to select the applications the user can access.

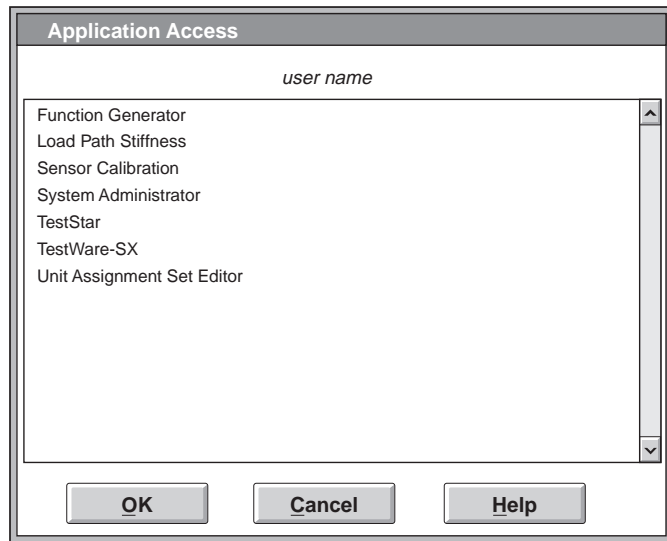

Using the window

Select (highlight) each application title you want the user to have access, then press the OK button.

New/Edit Application Window

The New Application and Edit Application windows are the same.

Completing this window displays the User Access window.

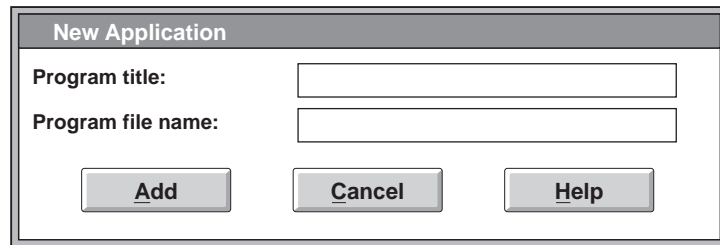

The screenshot shows a dialog box titled "New Application". It contains two text input fields. The first is labeled "Program title:" and the second is labeled "Program file name:". Below the input fields are three buttons: "Add", "Cancel", and "Help".

How it works

When you install a TestWare application using the Setup program, the application is automatically put in the appropriate directory. In most cases, this is TS directory.

The purpose for this window is to let the System Administrator program know that a new application has been added and which user names can access the application.

Using the window

The name you type into the Program title entry field is the how the application is listed in the main System Administration window.

The Program file name is the complete path for the application .EXE file. Use the following form to type the program file name (where filename is the name of application file and EXE is the extension).

C:\TS2\filename.EXE

For example, select the TestWare-SX application and press the Edit button. Notice that the Program tile is TestWare-SX and the Program file name is C:\TS2\TWSX.EXE. Press the Cancel button to return to the main window.

After you add or edit an application, you select which users can run the application.

User Access Window

This window shows the name of the application and all the user names.

Use this window to select the users can access the application.

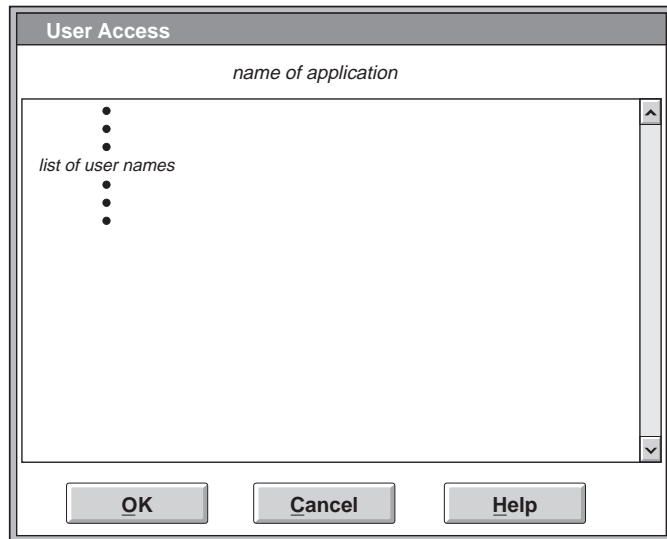

Using the window

Select (highlight) each user name you want to have access to the application, then press the OK button.

Creating a New User

This procedure describes how to define user names, their passwords, and what TestStar programs the user name can access.

Note This is the same procedure as described in Task 6 in Chapter 5 of the Installation Manual.

1. Open the System Administration program 240
 2. Add or edit a user name 241
 3. Select the TestStar programs the user can access 242
 4. Close the program 242
-

Step 1 Open the System Administration program

- A Double-click the MTS-TSII icon on the desktop. (OS/2 only) Then double-click the Utility folder.
- B Double-click the Administrator icon.
- C You may need to log into the Administrator program. Enter your user name and password in the MTS Login window.

By default, the System Administration window is ready to define a new user name when the program first starts.

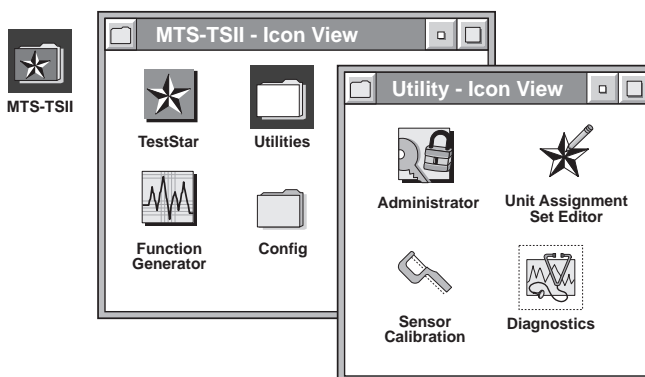

Step 2 Add or edit a user name

- A Press the Add or Edit button to display the New or Edit User window.
- B Enter or edit the information in the window as shown below. All the fields are mandatory except for the Last name, Middle initial, and First name.
- C When you have completed the window, press the Add button to bring up the Application Access window.

If you are editing an existing user, press the Edit button. This also brings up the Application Access window.

The information you enter is not case sensitive.

The New User window and the Edit User window are the same, except for the name of the Add or Edit button.

The screenshot shows a 'New User' window with the following fields and callouts:

- Username:** Elvis (Mandatory)
- Password:** blue_shoes (Mandatory)
- Last name:** Niesen (Optional)
- Middle initial:** M (Optional)
- First name:** Jim (Optional)
- Configuration:** none (Optional)
- Unit Assignment:** Siset (Optional)

Callouts:

- "These are mandatory fields." points to Username and Password.
- "These are optional fields." points to Last name, Middle initial, and First name.
- "Both the Configuration and the Unit Assignment can be changed after you login to TestStar." points to Configuration and Unit Assignment.
- "If a configuration file has not been created, type in **none** for now (no path is needed). It can be changed later." points to the Configuration field.

- ◆ The Configuration file name must show the full path for the file's location. In addition, the extension .TCC is required. A configuration file named **none** lets you open TestStar without any selections made. All parameter values and selections are blank.
- ◆ The Unit Assignment is selected from a list of predefined unit assignment sets.

Step 3 Select the TestStar programs the user can access

Click (to select) the applications that the user can have access to.

- ◆ This sample user has access to two applications, but is barred from another four.
- ◆ Press OK when done.

For example, Elvis can open the only Function Generator and TestWare-SX applications.

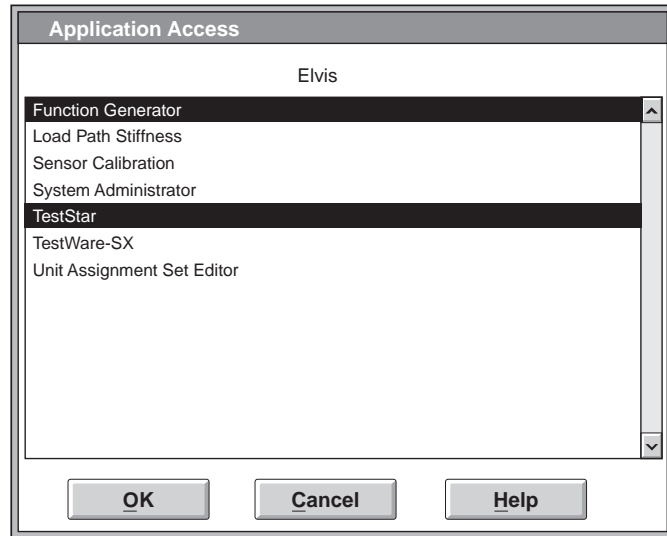

Repeat steps 2 and 3 for each new user you want to create.

Step 4 Close the program

Close the program by double-clicking the system menu icon (upper left corner of the window).



TestStarTM II

Control System

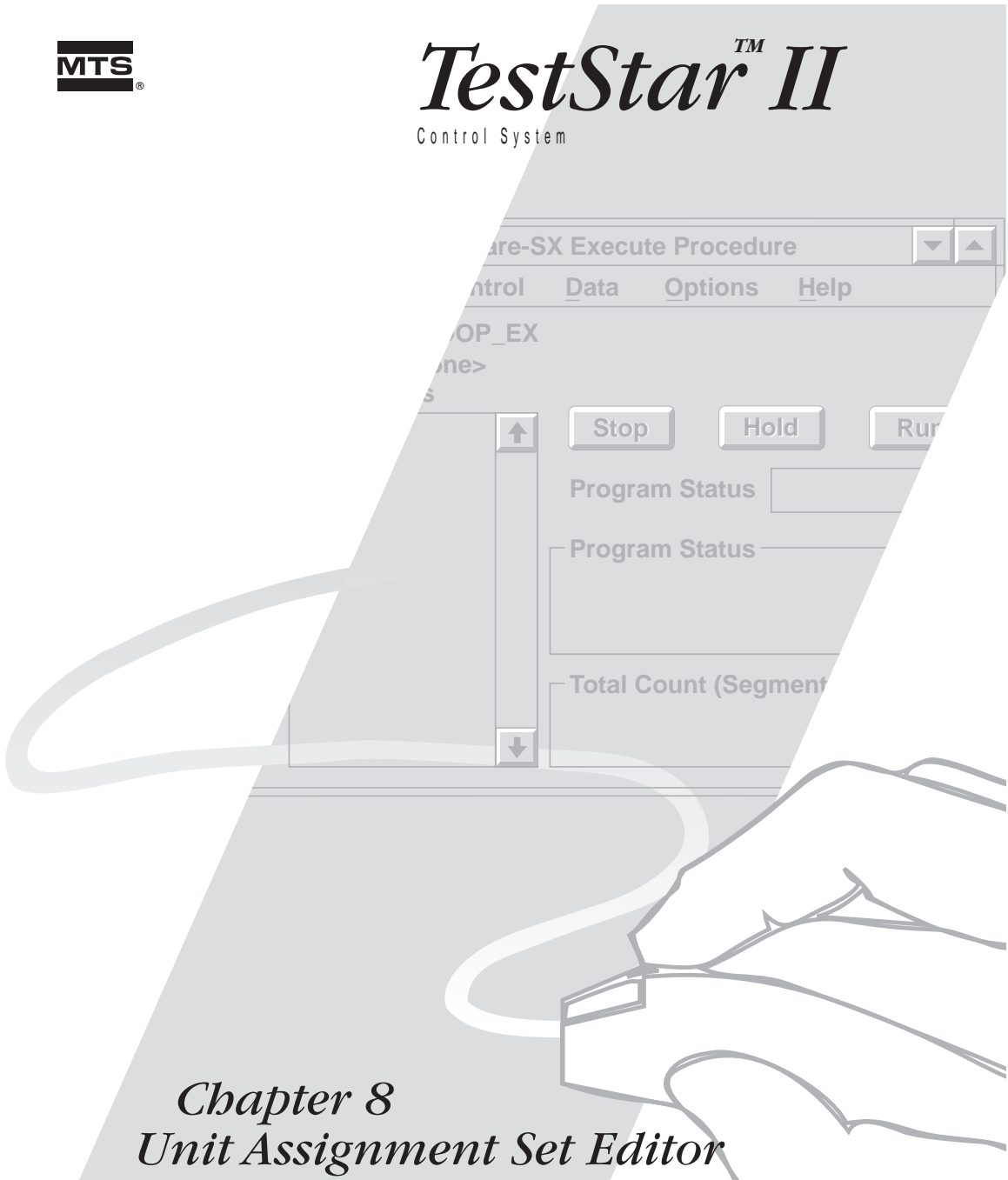

Chapter 8 *Unit Assignment Set Editor*

Unit Assignment Set Editor



Unit Assignment Set Editor

File Help

- New
- Open
- Save
- Save as
- Delete
- Global default
- Print
- Exit

Description

_____ for the unit set Clear

Dimensions

list of dimensions

Units

list of available units for the selected dimension

Open Unit Assignment Set

selected unit set

Unit Set Names

list of unit sets

Open

Save Unit Assignment Set

selected unit set

Unit Set Names

list of unit sets

Save

Delete Unit Assignment Set

selected unit set

Unit Set Names

list of unit sets

Delete

Assign Default Unit Assignment Set

selected unit set

Unit Set Names

list of unit sets

Assign Cancel Help

Unit Assignment Set Editor

The unit assignment set editor allows you to establish preferred sets of units that can be used as default units in TestStar.

Note When the TestStar software is installed, one of the standard unit assignment sets is assigned as the default unit set.

Contents

Unit Assignment Set Editor Window	248
Open Unit Assignment Set Window	250
Save Unit Assignment Set Window	251
Delete Unit Assignment Set Window	252
Assign Default Unit Assignment Set Window	253
Defining a Unit Assignment Set	254

What is a unit

Units define parameter values. They are measurements such as inches, pounds, centimeters, and kips.

Units are grouped by types called dimensions. *For example*, a length dimension includes the units microns, millimeters, centimeters, inches, feet, meters, etc.

What is a unit set

A unit is an engineering unit (a unit of measurement). A unit set is a group of dimensions with a type of unit assigned to each dimension. You can create different groups of default units for different tests or to reflect your preference in units. Each user name can have a different unit set assigned to their login.

For example, a unit set may have centimeters assigned to the length dimension. Parameters that use length dimensions are automatically assigned to centimeters. You can always change the default unit assigned to a specific parameter

How it works

When you log into TestStar, your unit preferences are applied. Having a preferred set of units saves time. Whenever you select a dimension for a TestStar parameter, the preferred unit is automatically assigned. You can always manually change the default unit assignment for any parameter.

For example, assume millimeters is the assigned unit for length. When you define an input signal for the LVDT, you will select the dimension length. Since mm is automatically selected as the unit, you can skip the unit selection unless you want to change the unit to something else (such as cm or in).

Several windows in TestStar require values to be assigned and units selected for test parameters. When a window is opened the default units are assigned to each parameter.

Default units

The default units can be changed in each window. Units can be selected for specific parameters by using a list icon of the units field. Selecting a unit without brackets prevents that unit from being changed even if the default units are changed.

Default units are assigned to each dimension used by TestStar. Each parameter that uses units can be defined with default units; these selections are identified with a set of brackets ([]). All other units are considered hard units; these are the units you select from a unit list icon and are not affected by sets of default units.

Default units are identified with brackets ([]).

Length	^	[mm]	^
Force		cm	
Time		ft	
Frequency		in	
Temperature		m	
Temp Tolerance	v	mm	v

Standard unit sets

The Unit Assignment Set Editor includes 5 unit sets. These can be edited to create additional unit sets.

- ◆ CGSSET is a set of units that contain centimeters, grams, and seconds.
- ◆ ENGSET is a set of units that contain U.S. customary units that contain small U.S. customary units.
- ◆ SISET is a set of units that contain International System units.
- ◆ SISETSM is a set of units that contain small International System units.

TestStar dimensions

The following list shows the dimensions used by TestStar. The units assigned to each dimension are those for the SISET unit set.

DIMENSION	UNITS	DIMENSION	UNITS
Acceleration	mm/Sec ²	Stiffness	kN/mm
Angle	deg	Strain	mm/mm
Angle Rate	deg/Sec	Strain Rate	mm/mm/Sec
Area	Sq.mm	Stress	kN/Sq.mm
Compliance	Sq.mm/kN	Temperature	deg_C
Damping	kN-Sec/mm	Temperature Rate	deg_C/Sec
Energy	kN-mm	Temperature Tolerance	deg_C
EPV (Energy per Unit Volume)	kN-mm/ Cu.mm	Time	Sec
Force	kN	Torque	kN-mm
Force Rate	kN/Sec	Torque Rate	kN-mm/Sec
Frequency	Hz	Unitless	(none)
Length	mm	Volts	V
Length Rate	mm/Sec	Velocity	mm/Sec
Percent	%	Volume	Cu.mm
Segment Count	segments		

Unit Assignment Set Editor Window

The Unit Assignment Set Editor window creates different sets of units. A set of units is used as the default units for the parameters of the various TestStar windows.

Assign a unit for each dimension to create a unit set.

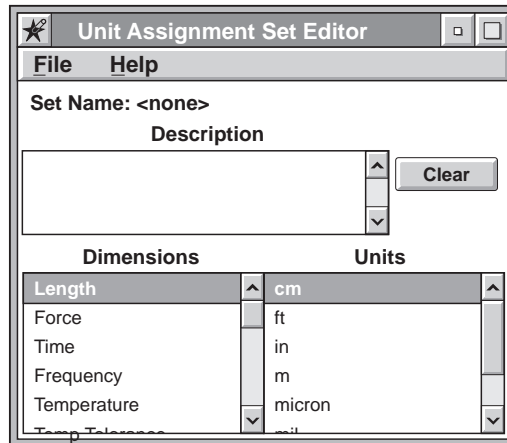

CONTROL

FUNCTION

File

Lists the file management selections.

Set Name

Shows the name of the unit set that is currently open.

Description

Displays a description of the unit set. You can type in this area. A description typically describes the set name.

Clear

Removes the description currently being displayed.

Dimensions

Displays a list of the dimensions used by TestStar.

Units

Displays the appropriate types of units that are compatible with the selected dimension.

Resets the current unit assignments to the first unit listed in each dimension, clears any description, and displays <none> as the Set Name.

Use New to create a new set of unit preferences for the dimensions.

Opens a previously defined set of units.

Saves the current Unit Assignment Set Editor settings you are editing. Displays the Save Unit Assignment Set window when you save the file for the first time.

Displays the Save Unit Assignment Set window where you can save the current unit set with a diiferent file name.

Deletes a previously defined set of units.

Assigns a default unit set. The default unit set is assigned to all users who have not selected a different set.

Closes the Unit Assignment Set Editor.

Prints the current unit set file.

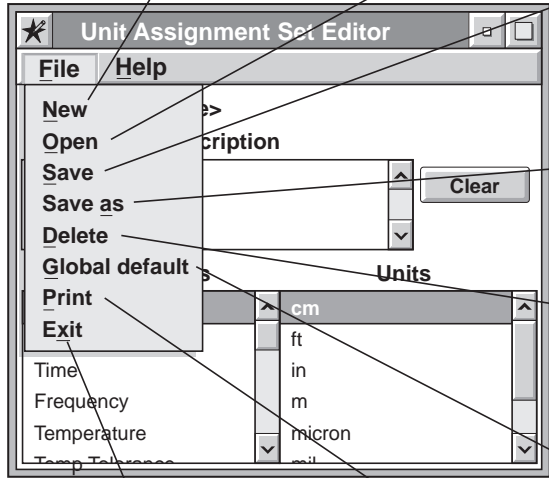

Open Unit Assignment Set Window

Use this window to select a set of units.

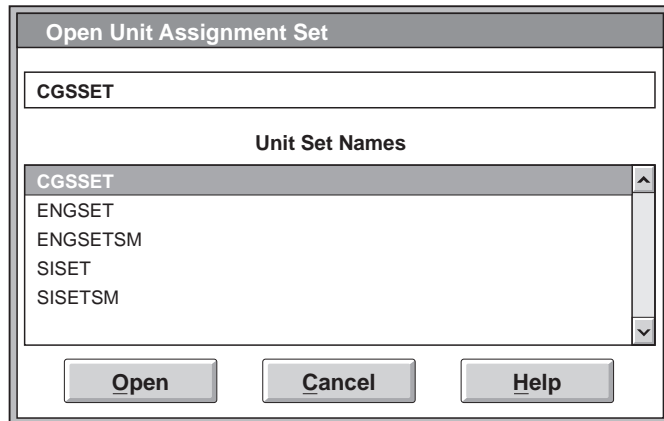

Using the window

Select a unit set from the list of defined unit set names. The selected set of units is shown in the entry field at the top of the window. Press the Open button to assign the unit set.

The unit set you open remains active until you select another unit set or exit TestStar.

Save Unit Assignment Set Window

Use the Save Unit Assignment Set window to store a set of default units.

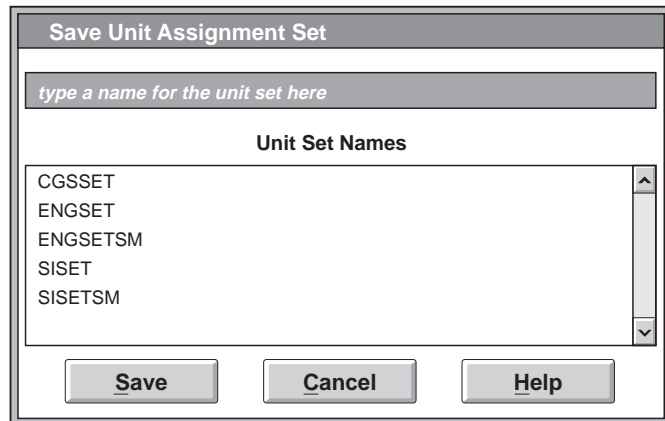

Using the window

Type the name of the unit set in the entry field at the top of the window. Press the Save button to save the set of units.

Delete Unit Assignment Set Window

Use the Delete Unit Assignment Set window to remove a set of default units.

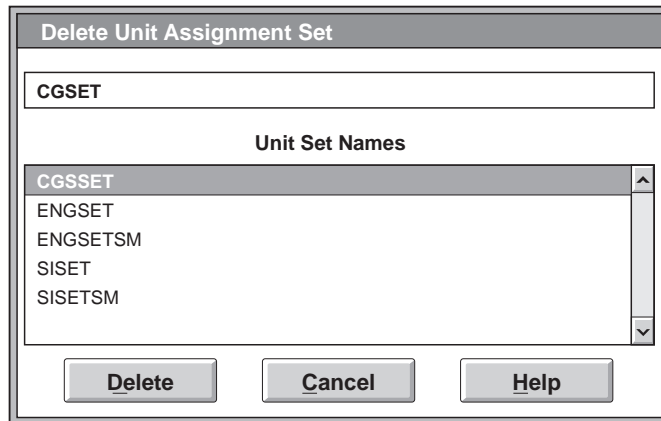

Using the window

Select a unit set from the list of defined unit set names. The selected set of units is shown in the entry field at the top of the window. Press the Delete button to remove the unit set.

CAUTION

Do not remove all of your unit sets.

At least one unit set must be available for use.

Assign Default Unit Assignment Set Window

Use the Assign Default Unit Assignment Set window to assign a set of units as the default set of units for users who have not selected their own defaults.

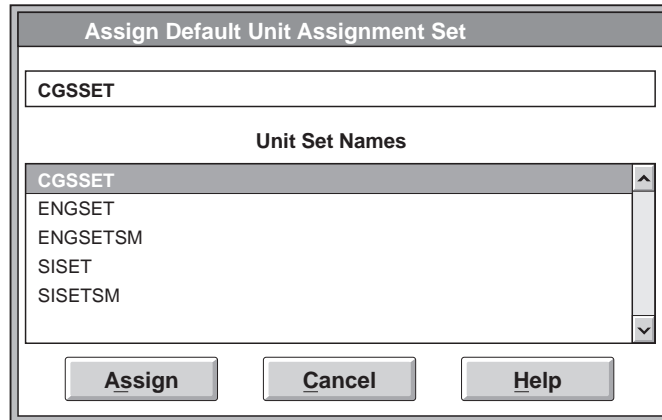

Using the window

Select a unit set from the list of defined unit set names. The selected set of units is shown in the entry field at the top of the window. Press the Assign button to assign the unit set as the default units for users who have not selected a default set of unit.

You can assign a different set of default units with the Assign TestStar Configuration window (accessed through the TestStar File menu). In this manner a set of default units are assigned only to the user who logged onto TestStar.

Defining a Unit Assignment Set

This procedure shows you how to create a set of units or open a predefined unit set.

Procedure

1. Open the Unit Assignment Set Editor program 254
2. Assign a unit to a dimension 255
3. Repeat step 2 for each dimension you expect to use 255
4. Save the unit assignment set 256
5. Assign a unit set as the default set 256
6. Close the Unit Assignment Set Editor 256

Step 1 Open the Unit Assignment Set Editor program

- A Double-click the MTS-TSII icon on the desktop.
(OS/2 only) Then double-click the Utility folder.
- B Double-click the Unit Assignment Set Editor icon.
- C You may need to log into the Unit Assignment Set Editor program.
Enter your user name and password in the MTS Login window.

The Unit Assignment Set Editor is ready to define a new set of units.

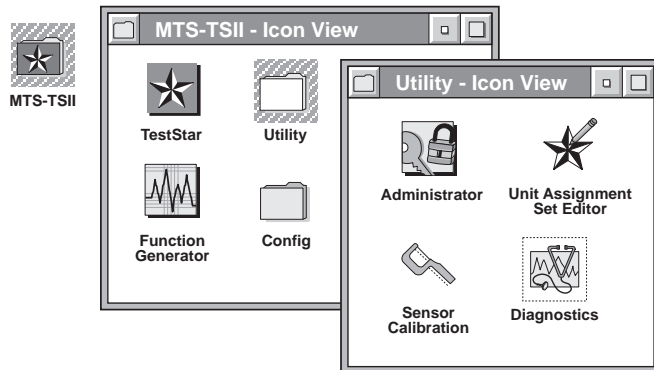

Step 2 Assign a unit to a dimension

You may use the File menu to open one of the five predefined unit assignment sets. You may use one of these sets to modify (or assign as the default set—see step 4)

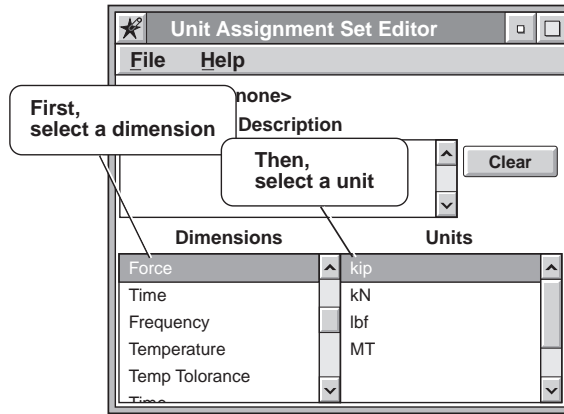

Step 3 Repeat step 2 for each dimension you expect to use

These are dimensions we will use in the examples of initial software settings.

You can select your own set of preferences.

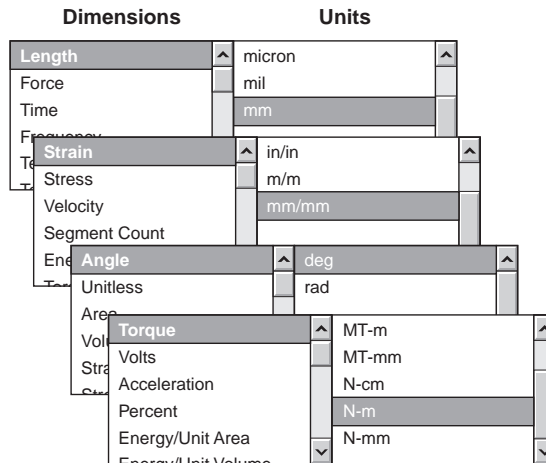

Step 4 Save the unit assignment set

- A If you want, type a description of your unit assignment set in the Description entry field.
- B Select Save or Save as in the File menu.
- C Type a file name in the entry field and press the Save button.

If you are creating a new file, the Set Name: <none> is shown. Select Save in the File menu.

If you are editing an existing file, the name of the file is shown. Select Save as in the File menu so the original file isn't replaced.

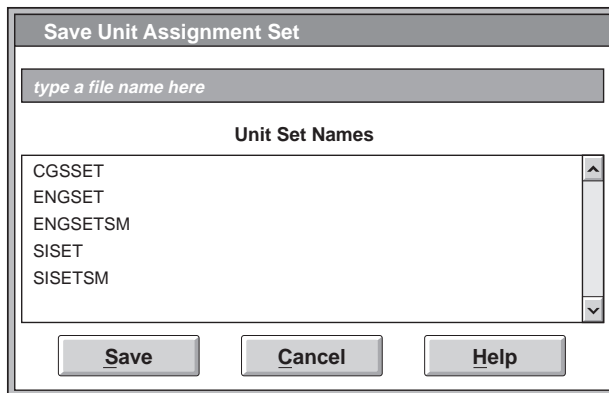

Step 5 Assign a unit set as the default set

Select Global default in the File menu. Select the file you want to be as the default unit assignment set.

Any TestStar configuration can have another unit assignment set assigned.

You can also change the unit assigned to any individual parameter of a TestStar configuration.

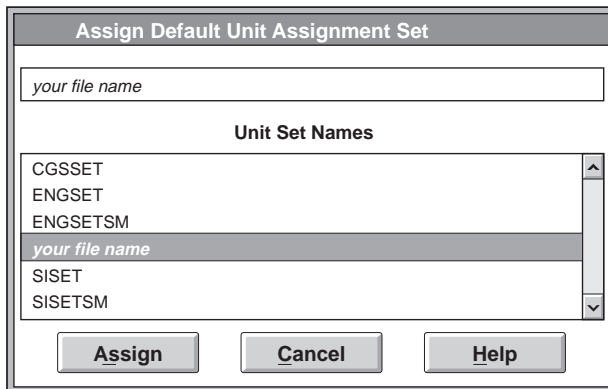

Step 6 Close the Unit Assignment Set Editor



TestStarTM II

Control System

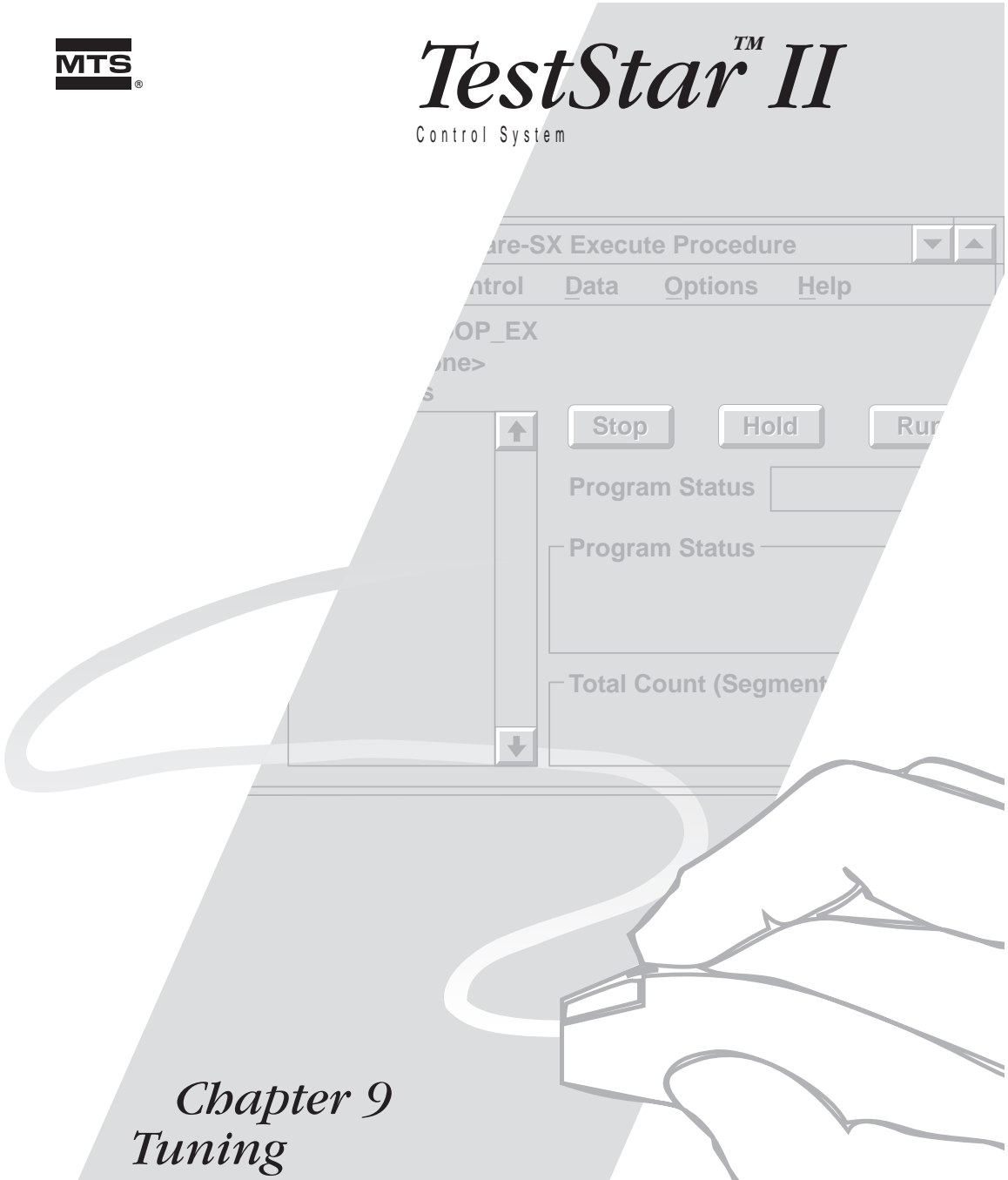

Chapter 9 Tuning

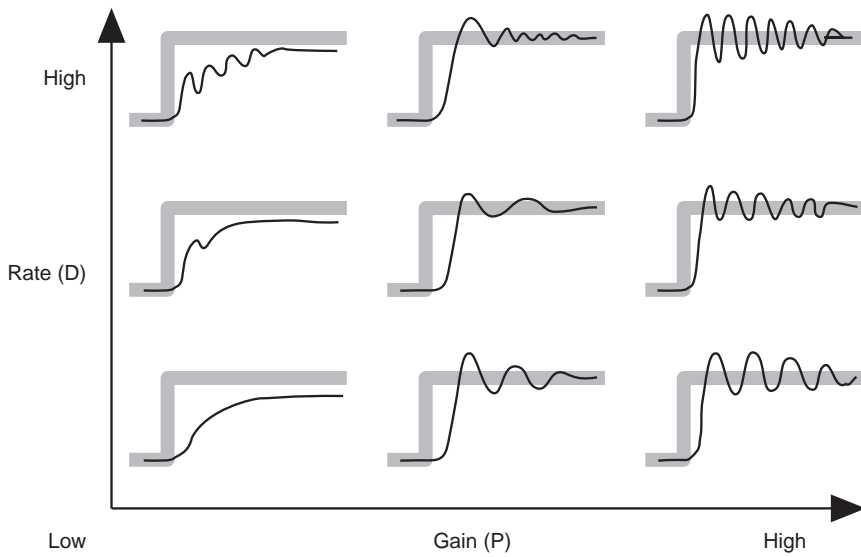
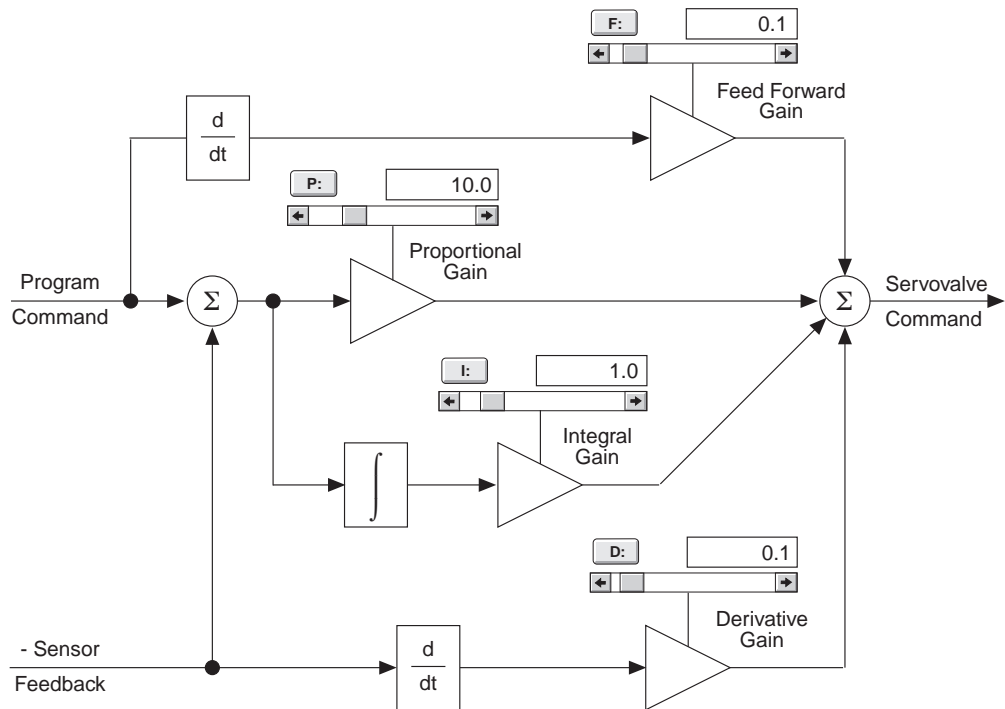

Chapter 9

Tuning

This chapter describes tuning the servo loop. Tuning adjusts the servo loop to optimize the relationship between the sensors, the test command, and the servovalve.

Contents

About Tuning	260
About Control Modes	265
About the Tuning Controls	270
About the Tuning Program	274
About the Servovalve	276
About Specimens	277
Monitoring Waveforms	278
Auto-tuning	281
Auto Tuning the First Control Mode	283
Auto Tuning Additional Control Modes	285
Tuning Procedure	288

CAUTION

Every control mode must be properly tuned. Using a poorly tuned control mode may cause the actuator to:

- **move so slowly it may appear not to be working,**
- **make an obnoxious noise (unstable operation),**
- **or in extreme cases, slam to its mechanical limit.**

Be sure you know the following before you tune:

- the Safety Precautions in the Preface of the Installation manual
 - the contents of this chapter,
 - how the adjustments affect your system,
 - how to use the error detector and limit detectors to help stop the system if it performs outside your expectations
 - that you need to retune when testing specimens with different characteristics (rubber vs. steel).
-

About Tuning

Tuning affects the control accuracy and stability of the servo control loop. Proper tuning improves the performance of the system (like setting an automobile's timing). The purpose for tuning is to optimize the system to be able to accurately deliver demanding system test programs while maintaining acceptable levels of stability.

- ◆ Each control mode uses a different sensor feedback signal for servo loop control. Each control mode needs to be tuned.
- ◆ Each sensor usually has several ranges. Only ranges used for control need to be tuned.
- ◆ Tuning DOES NOT affect measurement accuracy.

Tuning minimizes the system error and phase lag in the selected control mode.

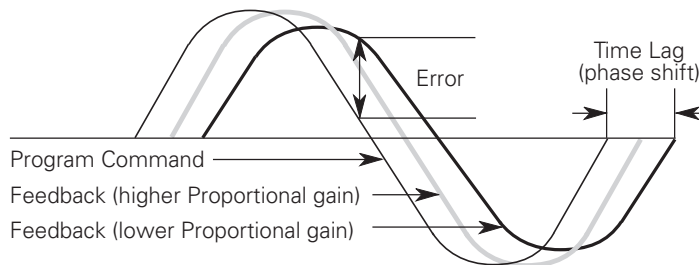

Inaccurate tuning

Inaccurate tuning causes a greater error and phase lag between the program command and the sensor feedback. A large error may indicate that the full potential of the program command is not being applied to the specimen.

- ◆ It indicates reduced control accuracy and repeatability.
- ◆ It does not indicate reduced measurement accuracy.

Precise tuning

Precise tuning ensures the program command requirements are applied to the specimen. This is your goal.

If you've never tuned before

Until you are experienced at tuning, you probably don't know what each tuning control does. The only way to find out what they do is to adjust them and see what happens. In other words, experiment with the controls. However, before you begin adjusting the controls with reckless abandon, please review the following guidelines:

- ◆ Set up the upper and lower limits for the LVDT and force sensor.
- ◆ Tune the displacement control mode first (no specimen is needed).
- ◆ While the tuning program is running, note the shape of the waveform you choose to monitor.
- ◆ Note the value of the tuning control you intend to adjust so you can return it to that value if necessary.
- ◆ Make a small adjustment with a control and note how the waveform changes. If the waveform doesn't appear to change, make a bigger adjustment.
- ◆ Use the auto-tuning feature to establish your initial tuning values.

What if I adjust something wrong?

If you make an inappropriate adjustment, the system will go unstable or shut down. An unstable system produces an obnoxious sound. A system shutdown displays the Fault Status window.

- ◆ If an adjustment causes the system to go unstable, readjust the control until the noise stops.
- ◆ If an adjustment causes the system to shut down, readjust the control to the last level where the system was running OK. The reason for the shutdown is listed in the Fault Status window; usually it's caused by a detector. Reset the system and continue tuning (see *Using the Fault Status Window* in Chapter 1).

Saving the tuning parameters

The tuning values are saved as part of the TestStar configuration file. See *Using Configuration Files* in Chapter 1 for more information.

When to tune

Tuning is needed whenever any of the following events occurs:

- ◆ A change in the compliance or size of the test specimen. *For example*, you were testing steel and change to rubber.
- ◆ The servo hydraulic configuration has changed. *For example*, a servovalve is replaced or changed to a different capacity.
- ◆ The system is sluggish (slow to react or not reaching the desired peaks). However, this is not always a tuning problem — it could be insufficient velocity capability, such as that resulting from a low-capacity servovalve.
- ◆ If a control channel or sensor is recalibrated.
- ◆ The system is unstable (indicated by a humming or screeching sound).
- ◆ When you observe poorly controlled accuracy.
- ◆ When you create a new control mode (all control modes should be tuned). Or, if the sensor for a control mode is changed.
- ◆ The end levels or frequencies are significantly different from those observed earlier in the test. *For example*, you notice that the specimen characteristics change during the test.

Checklist

Use this checklist when you tune a system. You need to determine the following:

- What type of control mode do you wish to tune? Read *About Control Modes*.
 - What controls should you use? Read *About the Controls*.
 - What kind of a tuning program should you use? Read *Creating a Tuning Program*.
 - Do you have a dummy specimen? Read *About Specimens*.
 - Where to connect the oscilloscope and what signal to monitor? Read *Monitoring a Waveform*.
 - Disable any compensation functions (such as amplitude control or phase control). See the Function Generator chapter or the appropriate TestWare application manual.
-

What to do first

The following are tasks that should be completed before you tune. It is not necessary to perform every task each time you tune. The condition of your system dictates which of the following tasks you must perform.

For example, a new system or a system under complete recalibration requires all of the following to be completed. If you are performing periodic or fine tuning, review the following and determine which tasks you need to complete.

- ◆ Disable any compensation functions (such as amplitude control or phase control). These functions should be used after the system is properly tuned.
- ◆ Connect an oscilloscope to your system or use the TestStar scope. You need to monitor the sensor signal or error signal for the control mode you intend to tune. Go to *Monitoring a Waveform* for help.
- ◆ Balance the servovalve. The electrical valve balance adjustment compensates for minor mechanical imbalance—it's an intermediate adjustment. Go to *About the Servovalve* and perform the electrical valve balance adjustment procedure.
- ◆ Calibrate each sensor used for a control mode or data acquisition. Go to the Installation manual and perform the appropriate calibration procedure.

Note *MTS Systems Corp. installs each TestStar system with an initial tuning setup. We also provide sensor calibration files on disk (if you purchase sensor from us). If your system doesn't have a calibrated sensor or an initial tune, contact MTS Systems for assistance.*

If your sensor calibration schedule doesn't require calibration at this time, perform a shunt calibration check to determine if your sensor/dc conditioner is within tolerance.

- ◆ If you have a three-stage (Series 256 or 257) servovalve, tune the inner loop (gain and rate) before tuning the outer loop. The rules for inner loop tuning are similar to those of the outer loop. Go to Appendix B in the Installation manual for help.

Optimizing tuning

Optimal system operation may require a level of detuning to compensate for specimen changes during a test.

- ◆ A precisely tuned system provides the greatest level of response, but this places the system near the point of oscillation or instability.
- ◆ Inaccurate tuning reduces the response. This makes the system “mushy,” and the actuator may not even reach the peak the program command calls for.
- ◆ As a specimen changes characteristics during testing, the response of the system also changes. This can cause unstable system operation. In this case, you may not want the most precise tuning.
- ◆ For the greatest control accuracy, use a compensation feature that can be found in several MTS software products.
 - Amplitude/mean control in the Function Generator.
 - Spectrum Amplitude Control (SAC) with the file playback process in the TestWare-SX application.
 - Phase Amplitude Control (PAC) used in conjunction with the 790.00 TestStar software, the 790.31 Dynamic Characterization application, and the 790.14 Advanced Function Generation processes.
 - FIT compensation (frequency based iterative technique) used in conjunction with the TestWare-SX application, and the 790.14 Advanced Function Generation processes.

CAUTION

The following can be dangerous if you do not know how it will affect your system.

The following items apply to expert operators who are experienced at precision tuning.

- You may need to retune the system response when the characteristics of the specimen change during a test.
 - You may also want to tune the system with the test program command after the initial tuning is accomplished.
-

About Control Modes

A control mode uses sensor feedback and a program command to control the servovalve. Each control mode has different tuning characteristics. There are three types of control modes:

- PIDF
- CLC
- CASC

PIDF control mode

PIDF stands for a group of gain controls—proportional (gain), (reset) integration, (rate) derivative, and feed forward. This is the most commonly used control mode.

SG command

The command source comes from a segment generator (i.e., function generator, TestWare application) and used for specimen testing.

Pod command

The command source comes from the Actuator Positioning Control on the load unit control panel and is also used for specimen installation. A Pod command source operates fine if you use 50% - 100% of the proportional gain setting of a tuned PIDF - SG control mode.

Ext command

The command source comes from a segment generator from an external device (i.e. a profiler, function generator) and is used for specimen testing. See Chapter 10 in the Installation manual.

The PID adjustments are also called gain (P), rate (D), and reset (I) (which imply the order of their use).

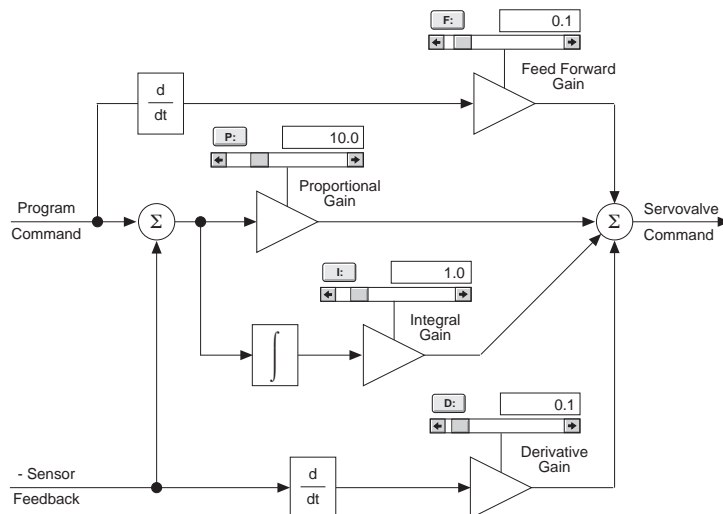

Length control

A length control mode uses the LVDT sensor in the actuator as the controlling feedback source.

- ◆ The length control mode only needs to be tuned once.
- ◆ Does not need a specimen installed for initial tuning.
- ◆ Uses a square wave when tuning an LVDT but not when tuning a displacement gage.
- ◆ If gain is too low, there may not be any actuator movement.
- ◆ If gain is too high, the actuator will move quickly and noisily.
- ◆ Tune once, then tune again if you change the grips.

Force control

Force control uses a force sensor (also called a load cell) as the controlling feedback source.

- ◆ Tune for each type of specimen or any changes in the force train.
- ◆ Requires a specimen to be installed.
- ◆ Uses a triangle waveform for the initial tuning. If the required results cannot be achieved, change to a square waveform.
- ◆ If gain is too low, the system may be unstable at low frequencies with large static offsets.
- ◆ Tune for each type of specimen and changes in force train.

Strain control

Strain control uses an extensometer or strain gage bonded to the specimen as the controlling feedback source.

- ◆ Tune for each type of specimen or any changes in the force train.
 - ◆ Requires a specimen to be installed (you may choose to use a broken specimen).
 - ◆ Uses a triangle waveform for the initial tuning.
 - ◆ Do not use a square waveform for tuning. A square wave can cause the extensometer to move or fall off the specimen, which can cause the system to go unstable.
 - ◆ The expected range for the proportional gain setting may be much greater than that for of length or force.
 - ◆ If gain is too low, the system may be unstable at low frequencies with large static offsets. Or, it may be uncontrollable.
 - ◆ Tune for each type of specimen.
-

CLC control mode

The CLC (channel limited channel) control mode is used to install specimens into the grips of a load unit. This control mode uses two feedback channels, one to move the actuator (master) and one to limit the movement (limiting).

This CLC control mode can only be used with the Actuator Positioning Control on the load unit control panel.

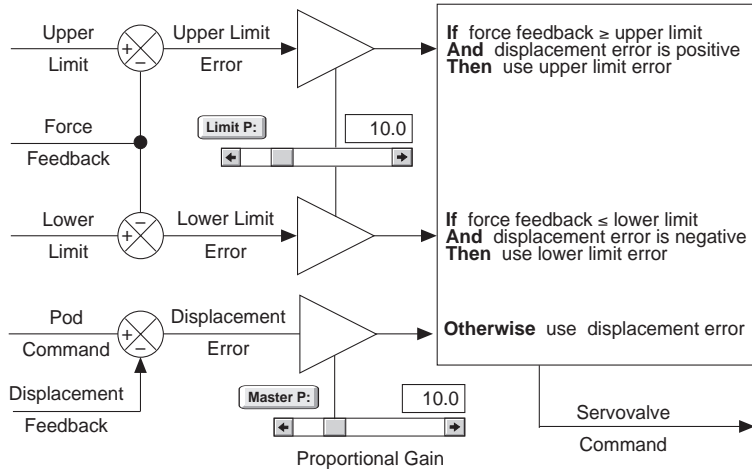

Note The easiest way to tune a CLC mode (for average use) is to use the same values as the proportional gain (P) values from any tuned PIDF control mode (of the same signal type, range, and specimen type) for the master P and limiting P values.

- ◆ It typically uses length feedback to move the actuator and force feedback to stop actuator movement when a force limit is detected.
- ◆ It gets its command from the Actuator Positioning Control on the load unit control panel and is designated Pod.
- ◆ If you want tighter control, use higher gain levels for the limiting channel.
- ◆ Adjust the Master P control for adequate actuator response to an Actuator Positioning Control adjustment.
- ◆ Monitor the force output and adjust the limiting channel control to minimize any delay to stop actuator movement when it reaches the specified limit.

Cascade control mode

The cascade (CASC) control mode is used for specimen testing that requires a high degree of stability during dynamic tests. It is like two control modes in series; the output of the first control mode (outer loop) is the command source for the other control mode (inner loop).

Note *The inner and outer loops of a cascade control mode should not be confused with the inner and outer loops found in a system using a Series 256 or 257 Servovalve. These are two different parts of a servo loop that happen to use the same terminology.*

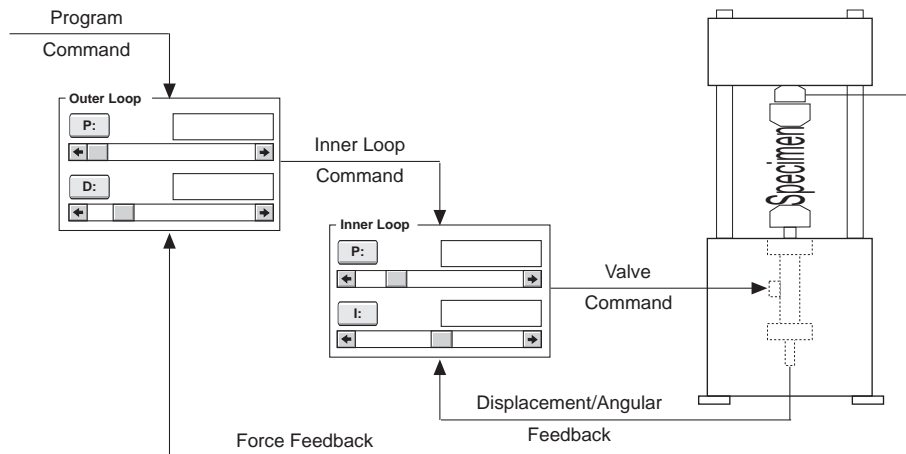

- ◆ Proportional gain and integral gain (reset) are the inner loop tuning controls.
 - Use the proportional gain and integral gain values from a tuned PIDF control mode that uses the same feedback as the inner loop.
 - The inner loop typically uses a length feedback with the inner loop command from the outer loop.
- ◆ Proportional gain and derivative gain (rate) are the outer loop tuning controls.
 - Adjust the outer loop using the same technique as a PIDF control mode after values are established for the inner loop.
 - The outer loop typically uses force feedback with a command from a segment generator (the function generator or a TestWare application).

About the Tuning Controls

TestStar includes four tuning controls. You do not need to use all of the controls to properly tune your system. *In fact, most testing can be accomplished with just the proportional gain adjustment.* The other adjustments introduce a signal to the command to compensate for specific situations.

Note Throughout this chapter the terms *gain, rate and reset* represent *proportional gain, rate derivative, and reset integration* respectively.

Inadequate adjustment

It is possible (and probable on a new system) that the amount of adjustment for a control is inadequate. If you reach the maximum adjustment value, press the adjustment button (such as **P**) and use the Set Scroll Range window to change the range of the adjustment.

Proportional gain (P)

Proportional gain is used for all tuning situations. It introduces a control factor that is proportional to the error signal. Tuning:proportional gain

- ◆ Higher gain settings increase the speed of the system response.
- ◆ When monitoring the error signal, increases in gain reduce the maximum amplitude of the error signal.
- ◆ Too much proportional gain can cause high frequency oscillation.
- ◆ The rule of thumb is—adjust gain as high as it will go without going unstable.

The tuning command is shown as a gray square waveform, and the black waveform is the sensor feedback.

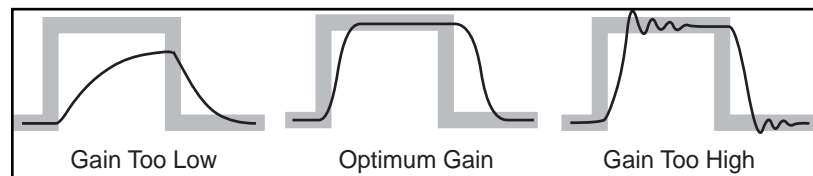

Rate derivative (D)

Rate is used with dynamic test programs. Rate introduces a “derivative of the feedback signal.” This means it anticipates the rate of change of the feedback and slows the system response at high rates of change.

- ◆ Adjusting rate reduces ringing. It provides stability at higher gain settings. It can reduce noise from high gain settings.
- ◆ It can amplify noise from noisy sensors.
- ◆ Series 256 and 257 Servovalves always need rate applied.
- ◆ Tuning the inner loop of a 3-stage servovalve always benefits if rate is applied.
- ◆ Higher rate settings tend to decrease system response.
- ◆ Too much rate can create instability at high frequencies.
- ◆ Too little rate can make a rumbling sound. The correct amount of rate is quiet. Way too much rate can make aringing or screeching sound.

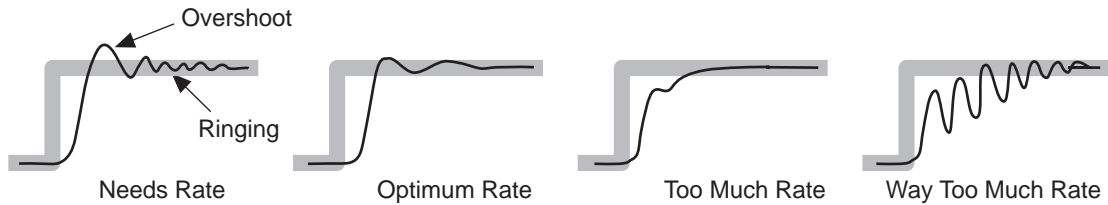

Reset integration (I)

Reset introduces “an integral of the error signal” that gradually, over time, boosts the low-frequency response of the servovalve command.

- ◆ It improves mean level accuracy.
- ◆ It corrects feedback droop caused by the spring characteristic of the servovalve in static and very low-frequency test programs.
- ◆ It maintains the mean level in dynamic test programs.
- ◆ Can be used to minimize the amount of time the system needs to recover from transitions.
- ◆ Use the Max./min. meter to monitor the mean level. Reset the meter after each adjustment.
- ◆ Higher reset settings increase system response. Too much reset can cause a slow oscillation (hunting).
- ◆ Can be used to minimize the amount of time the system needs to recover from transients.
- ◆ A rule-of-thumb—set the integration rate to 10% of the proportional gain setting. You may want use the max/min display to monitor the mean level, reset the display, and check it again.
- ◆ May want to use the max/min display to monitor the mean level, reset the display, and check it again.

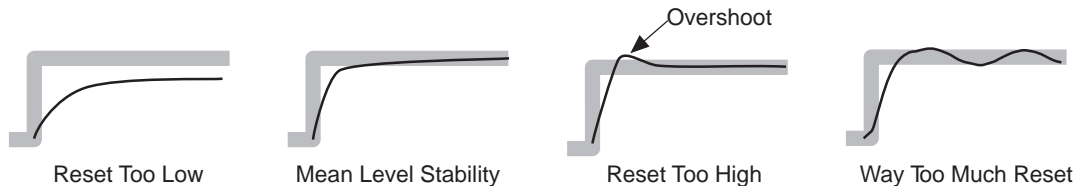

A ramp and hold waveform illustrate different levels of reset. In a cyclic waveform, peak and valley values drop the same amount if reset is not adjusted correctly. The Reset (I) Adjustment determines how much time it takes to improve the mean level accuracy.

Feed Forward (F)

Feed forward is like the Rate control except that it introduces a “derivative of the command signal.” It anticipates how much valve opening is needed to reach the required response and adds that to the valve command—like compensating for phase lag.

- ◆ It does not compensate for normal changes during testing (such as temperature changes, servovalve droop, etc.).
- ◆ It can correct a single natural frequency inherent in load units. Adjust feed forward if oscillation cannot be stopped.
- ◆ It is usually needed with force sensors attached to the end of an actuator (also called moving load cells).
- ◆ May be needed for systems with large actuators and massive grips.
- ◆ It is needed when testing a soft specimen in force control.
- ◆ May be used to minimize phase lag.
- ◆ Do not use with square wave.

This waveform shows the results of a moving load cell.

However, don't use a square waveform to adjust feed forward.

Adjusting feed forward causes the command to begin sooner so the feedback may track the original command more closely.

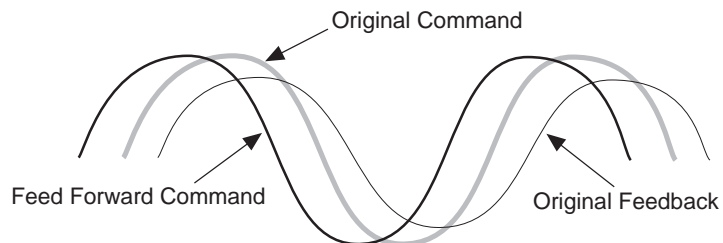
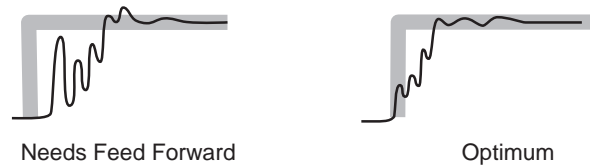

About the Tuning Program

The purpose of a tuning program is to produce a command that reflects the most demanding system response expected from a test. The all-purpose tuning program is a low-frequency, low-amplitude square wave command.

Note *The function generator is very useful for quickly setting up a tuning program. If you use the same tuning program on a regular basis and have the TestWare-SX application software, you may wish to create and save your tuning procedure.*

Waveform

Initial tuning is best done with a waveform that has abrupt changes. This excites the system at frequencies likely to be unstable with excessive gain. Square and triangle waveforms are preferred. Final tuning can be done with the actual program command for the test.

Note *Always monitor the sensor feedback or error signal to evaluate the control accuracy. See Monitoring Waveforms.*

Square

A square waveform requires the servovalve to open rapidly to a large opening. It is the most demanding waveform because it requires the maximum response from the servo loop system. It also places a large acceleration on the test system and specimen.

- ◆ A square waveform is most useful for tuning length (displacement).
- ◆ Do not use a square waveform when tuning a control mode that uses an extensometer. The large accelerations can cause the extensometer to move or fall off the specimen, which can cause the system to go unstable.
- ◆ Monitor the feedback or error signal to evaluate the system stability.

Triangle

A triangle waveform requires the actuator to move at a constant rate. This requires the servovalve to move quickly between two discrete openings.

- ◆ A triangle waveform is useful for all levels of tuning.

Continued...

Waveform (...continued)

- ◆ Use a triangle waveform if a square waveform creates excessive velocities or acceleration for the type of specimen being tested.
- ◆ Monitor the error signal to evaluate the system stability.

Sine

A sine waveform requires the servovalve to move at a variety of rates.

- ◆ A sine waveform is a poor waveform to evaluate system stability.
- ◆ Monitor the error signal to evaluate the system stability.

Frequency

A low-frequency waveform is adequate for most testing. Tests at higher frequencies cause a frequency shift that cannot be completely corrected with the PIDF adjustments.

- ◆ Do your initial tuning at a low frequency, then fine tune at the highest frequency in your test program. Common values are 1 - 2 Hz.
- ◆ Servo adjustments that do not improve performance at high frequencies generally indicate that the servovalve is running at 100% capacity or the HPS is running at 100% capacity.
- ◆ This characteristic can easily be seen when tuning with a haversine waveform. The feedback waveform appears to be more like a triangle waveform when running at 100% capacity.

Amplitude

A system tuned at a low amplitude may become unstable at high amplitudes. Tuning should be accomplished over a variety of amplitudes.

- ◆ Use a moderate amplitude (5% to 10% full scale) for initial tuning.
- ◆ Be sure the maximum velocity of the tuning command is 10% to 50% of the maximum velocity of the system.
- ◆ Increase the amplitude for fine tuning.
- ◆ You may find it helpful to check tuning over a variety of amplitudes by creating a test that cycles once at each of the target amplitudes. The test should acquire timed data at a rate of 1 kHz so you can evaluate the results for each amplitude.

About the Servovalve

Most of the servovalve adjustments are performed during the system installation and don't require periodic adjustment. However, the valve balance procedure may need periodic adjustment. See Appendix B in the Installation manual for the complete set of servovalve adjustments.

Adjusting valve balance

To adjust the valve balance, perform the following using the controls on the load unit control panel (with no specimen installed):

Note *For dual 252 servovalves, select separate balance controls if each valve is used for different tests; select combined balance controls if both valves are used for the same test.*

1. Auto zero force.
2. Set up for a Force Pod control mode (be sure it is tuned).
3. Monitor the force sensor output on the display.
4. Turn On the Actuator Positioning Control but DO NOT adjust it.

◆ If the actuator holds its position, valve balance is not needed.

◆ If the actuator moves, adjust the valve balance.

Note *Perform a mechanical adjustment if the electrical valve balance cannot be achieved. Go to the appropriate servovalve product manual for the mechanical valve balance procedure.*

When a mechanical valve balance is complete, perform this procedure again.

5. Adjust the Valve Balance control (in the Adjust Drive window) to stop the actuator movement. Make the adjustment before the actuator reaches its maximum displacement; otherwise, you will need to reposition the actuator and continue the adjustment.
-

About Specimens

Specimens can be very expensive. A dummy specimen is an inexpensive material that has similar characteristics to the specimen selected for testing. The most important characteristic is the specimen's spring rate. A dummy specimen can also be an extra testing specimen designated for tuning.

The advantage of a dummy specimen is that it can simulate how your testing system reacts to real specimen. You can establish a more precise level of tuning with a dummy specimen.

Note *If you have a dummy specimen you can use the normal tuning procedure.*

Tuning without dummy specimens

If you do not have a dummy specimen or if a dummy specimen is not practical, review the following recommendations if you must use a real specimen:

- ◆ Start your PIDF controls at minimum settings.
 - ◆ Do not use a square waveform for a massive specimen or a specimen sensitive to vibrations.
 - ◆ Adjust rate to minimize any oscillation, overshoot, or ringing in the waveform.
 - ◆ Be very conservative by beginning with a triangle waveform to establish initial control. Then use a waveform that resembles the test waveform to provide a precise level of control.
-

Tuning force without a specimen

A specimen is required to tune force and strain control modes. Initial force tuning may be accomplished with the actuator up against the force sensor. The actuator acts as a specimen reacting against the force sensor.

1. Adjust the load unit crosshead so the actuator can reach the force sensor.
 2. Carefully adjust the actuator using a tuned length control mode so it contacts the force sensor.
 3. You can now switch to force control and proceed with initial tuning.
-

Monitoring Waveforms

When you tune the servo loop you need to monitor the results of your adjustments. There are two ways to monitor a waveform during tuning.

- ◆ An oscilloscope is preferred.
- ◆ The TestStar scope is adequate if you don't have an oscilloscope.

Note Set up your scope to monitor the area of the waveform that shows characteristics useful for tuning. You can monitor the sensor feedback or the error signal of the control mode.

What to monitor

The accuracy of the waveform represents how well it reaches the amplitude of the command or how repeatable the end levels are. The peaks and valleys of triangle and haversine waveforms should be consistent. Use the area of the square wave after the ringing settles to monitor the end levels.

DO NOT monitor the entire waveform. Instead, zoom in on the area of interest.

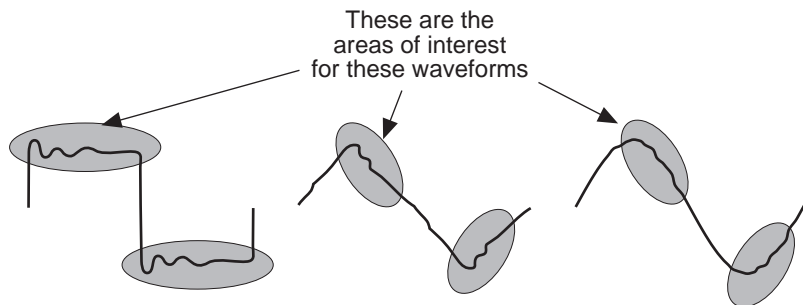

If the amplitude of the feedback cannot be achieved without going unstable, and the end levels are repeatable, simply increase the command to achieve the desired end levels.

Monitoring the error signal

The error signal shows similar characteristics as a feedback signal. The error signal represents the difference between the command and sensor feedback. The following show the error signal characteristics for each type of waveform.

A square waveform is best suited to view the overshoot and ringing characteristics that occur when tuning a system. Review the following waveforms to determine the kind of characteristics that can be found in an error signal.

The error signal from a square wave should show the feedback ringing centered on the zero reference.

A static accuracy difference in the error signal can be corrected with reset.

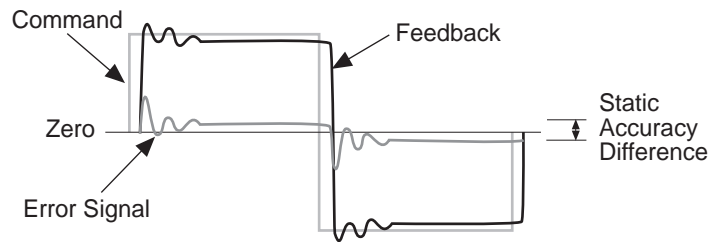

The square wave shape of the error signal represents the phase lag of the feedback signal.

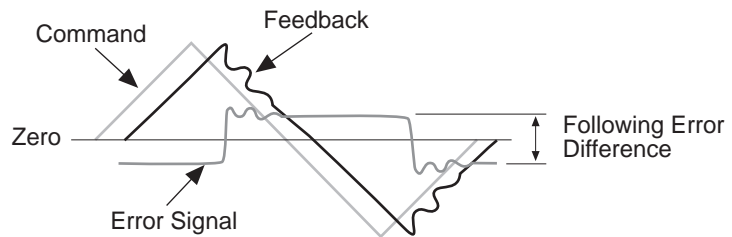

The error signal from a haversine should be a small amplitude sine waveform that looks like a rounded square waveform.

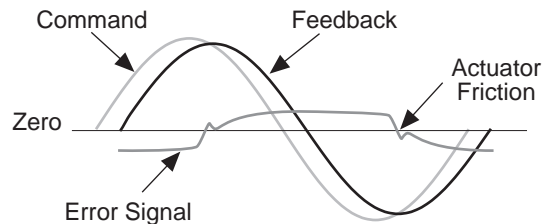

Using the TestStar scope

If you don't have an oscilloscope, use the TestStar scope feature for tuning control modes. See Chapter 3 and Chapter 5 in the Reference manual to set up the scope and use it. Review the following:

- ◆ Select a continuous sweep.
- ◆ Enter a refresh time that is longer than the trace time.
- ◆ Adjust the scroll bars on the Y axis to zoom into the area of interest.

Using an oscilloscope

An oscilloscope has a higher resolution and is faster than the TestStar scope. See Chapter 3 in the Reference manual to set up the analog output channel. Review the following:

- ◆ Be sure you have an output channel defined for readout.
- ◆ Set up a Readout channel to monitor the sensor signal of the input channel used for the control mode you intend to tune.

Or, you could monitor the error signal. You can tune using either signal. To monitor the error signal, set up a readout channel to use the analog bus.

- ◆ Set up the oscilloscope to monitor the feedback of the input signal or the error waveform.
- ◆ Connect the oscilloscope to the appropriate Readout connector on the rear panel of the digital controller (J71 - J76).

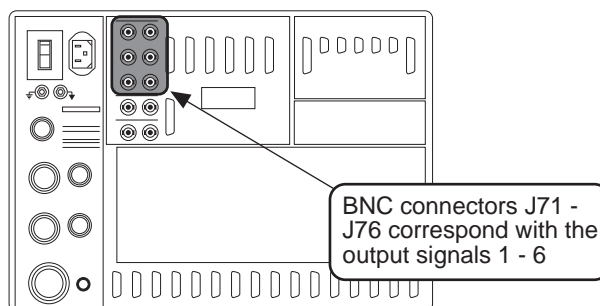

Auto-tuning

The auto-tuning feature automatically tunes control modes for a low to moderate level of tuning.

Prerequisite

The auto-tuning feature is only available for PIDF control modes using the segment generator (SG) command source.

How it works

Auto-tuning uses an auto-tuning control mode to control the actuator while the selected control mode is being tuned (except when the auto-tuning control mode is undefined). The first control mode to be auto-tuned should normally be a displacement or angular control mode which doesn't require a specimen. When the auto-tuning control mode is undefined, auto-tuning utilizes the full range of the input signal (i.e. full range of motion for a displacement control mode or full system capacity for a force control mode).

The first auto-tuned control mode is automatically selected to replace the undefined Auto-tuning Control Mode in the Edit Control Channels window.

Auto-tuning begins by moving the actuator using the auto-tuning control mode. While the actuator is moving, the feedback for the control mode being tuned is monitored to determine the response of the control mode. Once the feedback is evaluated, tuning parameters are calculated. The tuning values are displayed in the Accepting New Gains window.

Is auto-tuning good enough?

You may want to setup a cyclic test using an amplitude and frequency that is found in your test. Enable a compensator such as amplitude control. Set up a TestStar meter and monitor the peaks and valleys. If the peaks and valleys of the cyclic command are being achieved, the tuning is adequate.

If the peaks and valleys of the cyclic command are not being realized, go to the manual tuning procedure at the end of this chapter to achieve a higher level of tuning—higher response.

Error messages

The following are possible error messages related to auto-tuning.

◆ **The range between end levels is too small.**

Signal noise may be too large to use the selected end levels. Setup a min/max meter and monitor the feedback while in the hold state. Note the difference between the min and max readings. Multiply the difference by 10, the range between the auto-tuning end levels must exceed that difference.

◆ **There is not enough response from the feedback channel.**

This message appears when a command produces no detectable actuator response. Check the following:

- The feedback sensor may not be connected properly.
- Hydraulic pressure may be off.
- If a control mode requires a specimen to be installed, be sure the specimen is installed.
- The selected feedback may be much noisier than the feedback for the auto-tuning control mode.

◆ **The polarity of the feedback doesn't match the polarity of the valve.**

If a positive change in the valve opening results in a negative reaction in the feedback of the selected control mode, then the polarity of the sensor must be changed. Use the sensor calibration program to change the sensor polarity.

◆ **The system could not allocate or start a TestStar resource.**

This message appears if TestStar can't run a required resource. This usually means that another TestStar application is running. An application that acquires data or commands the servo loop can cause the error message.

◆ **Auto-tuning Canceled**

This message appears when you press the Stop Auto-tuning button during the auto-tuning procedure.

◆ **Controller next mode error interlock.**

This message appears in the Fault Status window. It indicates a saturated feedback signal from the auto tune control mode. Check the range of the input signal.

Auto Tuning the First Control Mode

If you have no tuned control modes, start with a displacement control mode. Even though the displacement control mode is not tuned yet, it is the most reliable control mode for this purpose.

Once the control mode has been tuned automatically, it can be used for testing and as a auto-tuning control mode. However, if you notice during your test that end levels aren't being reached, you may want to fine tune the control mode. Use the manual tuning procedure at the end of this chapter to achieve a higher level of tuning—higher level of response.

For example, tuning the first control mode requires feedback from displacement or rotation. This type of control mode can be governed to produce stable operation.

Step 1 Getting things ready

This step defines the full-scale range of the control mode. Auto-tuning with an undefined auto-tuning control mode requires a full-scale range. The full-scale range allows the actuator to be exercised across its full range of movement.

- A** Be sure that no specimen is installed and that the actuator can move through its full range of movement. You may need to move the crosshead or other fixtures that may be in the actuator's path.
 - B** Use the Adjust menu to select Input Signals. This displays the Adjust Input Signals window.
 - C** Select a displacement (or angular) input signal and select the 100% full-scale range.
 - D** Use the Adjust menu to select Tuning. This displays the Adjust Tuning window.
-

Step 2 Run the auto tune feature

This step sets up and runs the auto-tune feature.

Note *During auto-tuning, the command as seen on a scope doesn't reflect the actual command.*

- A** Press the Auto Tune button in the Adjust Tuning window. This displays the Auto Tuning window. TestStar displays two messages that remind you how auto-tuning works.
- B** The end levels are automatically set to the 100% full-scale range of the displacement control mode (which is what you want for this control mode).
- C** Press the Run Auto tuning button. The actuator will attempt to move through its full-scale displacement. It takes about 1-2 minutes for auto-tuning to move through its full range of movement.

Note *If the actuator doesn't move for more than two minutes, press the Stop Auto Tuning button. It is possible that the valve balance may need adjustment.*

While the auto-tuning feature works, the Running Auto Tuning window is shown.

Use the Stop Auto-tuning button to stop the process at any time.

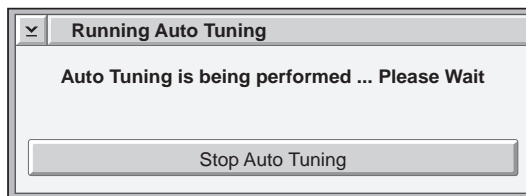

Step 3 Save the settings

- A** When tuning is complete, the Accept New Gains window appears. Press the Accept Gains button to use the tuning values. Otherwise, select cancel to dismiss the window without using the tuning values.
- B** Use the File menu to select Save. This adds the tuning values to the current TestStar configuration file.

Auto Tuning Additional Control Modes

Once you've tuned a displacement control mode, you can proceed to tune force or any other PIDF control mode.

Note *Non-linear specimens may produce invalid gains and should be rough tuned manually so you have an idea if the final tuning values are appropriate.*

For example, tuning a force control mode needs a tuned displacement control mode as the auto-tuning control mode. This allows the system to reliably control the actuator using the displacement control mode while monitoring the force sensor. Monitoring the force sensor data ensures the specified end levels are achieved.

Step 1 Getting things ready

This step prepares your system for auto-tuning. When tuning additional control modes you need to know what range is selected for the input signal of the control mode.

- A** If you want to auto-tune a control mode that requires a specimen to be installed, you may want to install it now. You will be prompted to do it later. Use a specimen that has characteristics similar to the specimen to be tested. Use the length control mode to install the specimen since it should already be tuned.
 - B** Use the Edit menu to select Control Channels. Check that the Auto-tuning Control Mode is the length control mode you tuned in the previous procedure. Or, you can use any stable, tuned, segment generator (SG) control mode.
 - C** Use the Adjust menu to select Input Signals. This displays the Adjust Input Signals window. Check or select a range for the input signal used for the control mode to be tuned. The range determines the maximum settings for the auto-tuning end levels.
 - D** Use the Display menu to select Input Signals. Set limits that are appropriate for the test for each sensor not being calibrated. If a specimen is used, set the limits so the specimen won't fail. Select "Hydraulics Off" or "Interlock" for each limit action.
 - E** Use the Adjust menu to select Tuning. This displays the Adjust Tuning window.
 - F** Select the control mode you want to auto-tune.
-

Step 2 Setting up the auto-tune feature

This step sets up and runs the auto-tune feature.

- A** Press the Auto-tune button in the Adjust Tuning window. This displays the Auto-tuning window.
- B** Enter two end levels that reflect the type of test you intend to apply to the specimen.

Note *For compressive only tuning set up end levels that are non-compressive, Do not set limits from 0 or above. The reverse is true for tensile only set ups.*

For example, assume you are to run a compressive test to 8 kN (with a 10 kN force sensor). Set the end levels to -2 and -8 kN.

- C** Press the Start Auto-tuning button.
- D** You are prompted to install a specimen into the load unit. The actuator must be left in contact with the specimen and the actuator positioning control (APC) turned off. Pressing OK displays the Auto-tuning in Progress window, and starts tuning the process. It takes about 1-2 minutes for auto-tuning to finish.

Note *If the actuator doesn't move for more than two minutes, press the Stop Auto-tuning button. It is possible that the valve balance may need adjustment.*

If you encounter an interlock while running the auto-tune feature, you may need to change either the limit of the interlock detector sensor, or the range of the sensor being tuned.

While the auto-tuning feature works, the Auto-tuning in Progress window is shown.

Use the Stop Auto-tuning button to stop the process at any time.

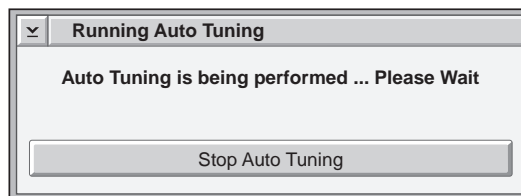

Step 3 Save the settings

- A** When tuning is complete, the Accept New Gains window appears. Press the Accept Gains button to use the tuning values. Otherwise, select cancel to dismiss the window without using the tuning values.

⚠ CAUTION**Non-linear specimens can produce invalid gains.**

Non-linear specimens should be rough tuned manually instead of using the auto-tune feature.

- B** Use the File menu to select Save. This adds the tuning values to the current TestStar configuration file.

Tuning Procedure

Tuning is affected by the type of mechanical components in your test system, the response of your test system and the type of specimen being tested. The following procedure provides general guidelines that will assist you in the tuning process.

Note Remember, adjust one control at a time and note the results before adjusting another control.

Prerequisite

You must be familiar with the information in the About Tuning section. We also assume that you already have a good knowledge of the TestStar software and how to load a specimen.

Procedure

1. [Getting things ready](#) 288
 2. [Adjust gain, rate and/or feed forward](#) 289
 3. [Adjust reset](#) 290
 4. [Tune each control mode and save your work](#) 290
-

Step 1 Getting things ready

This step describes what must be done before you can adjust the tuning controls.

- A** Set up an oscilloscope to monitor the sensor feedback.
 - B** If necessary, install a dummy test specimen.
 - C** Select or set up a tuning test command. Be sure your test uses the control mode you want to tune.
 - D** Open the Tuning window and note the settings for the tuning controls—you may need to re-establish these settings if your tuning efforts go un-rewarded.
 - E** Start the test command.
-

Step 2 Adjust gain, rate and/or feed forward

Your goal is to establish the best possible waveform that resembles the test command waveform. In theory, you can duplicate the test command perfectly. In practice, you will find that you cannot get a perfect waveform. You will need to determine what an acceptable waveform looks like.

- ◆ Adjust the gain (P) control to achieve a waveform between the optimum and high setting. This establishes a starting point.

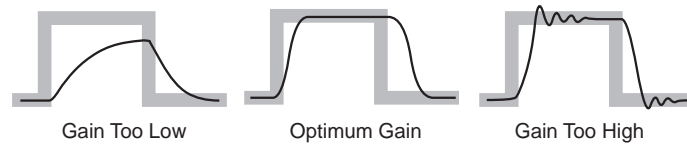

- ◆ Adjust the rate (D) control to remove overshoot. Then adjust the gain (P) control to introduce more ringing. Continue these adjustments to achieve the highest gain setting while maintaining a stable waveform. Review the following waveform table:

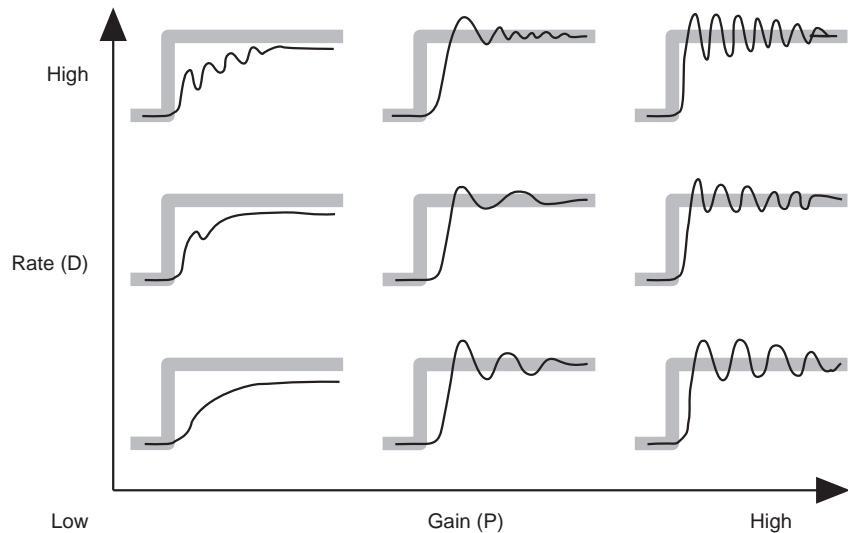

- ◆ You may need to reduce the rate setting to introduce a feed forward adjustment.
- ◆ Make small adjustments and observe the results

Continued...

Step 2 (...continued)

- ◆ If a stable waveform cannot be achieved with the rate adjustment, use the feed forward (F) adjustment.
- ◆ If your system goes unstable and you can't correct it quickly, stop the test command, reduce the adjustment settings, and try again.

Step 3 Adjust reset

To adjust reset (I) you may want to set up a peak/valley meter, or you could monitor the error waveform with the oscilloscope.

peak/valley meter

Monitor the peaks and valleys of the sensor signal. The peaks and valleys should be balanced. Before adjusting Reset, be sure the feedback signal is repeatable (i.e., the same peaks and valleys are achieved).

For example, assume the test command is centered on zero and the meter displays +3 mm and -5 mm. You want to adjust the reset (I) control to achieve ± 4 mm.

If the command is not centered on zero, monitor the difference between peaks and valleys of the sensor feedback to the upper and lower levels of the test command. Any difference should be the same.

square wave error signal

Monitor the amplitude of the settled portion of the error signal. The settled portion of the error signal should be the same level.

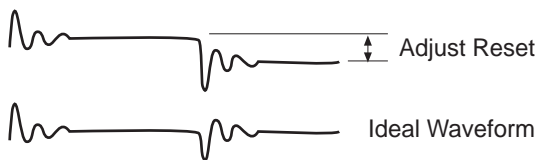

triangle wave error signal

Monitor the amplitude of the settled portion of the error signal. The settled portion of the error signal should be balanced.



Step 4 Tune each control mode and save your work

Repeat steps 1 - 3 for each control mode. Then use the TestStar File menu to save the Tune settings as part of a configuration file.



TestStarTM II

Control System

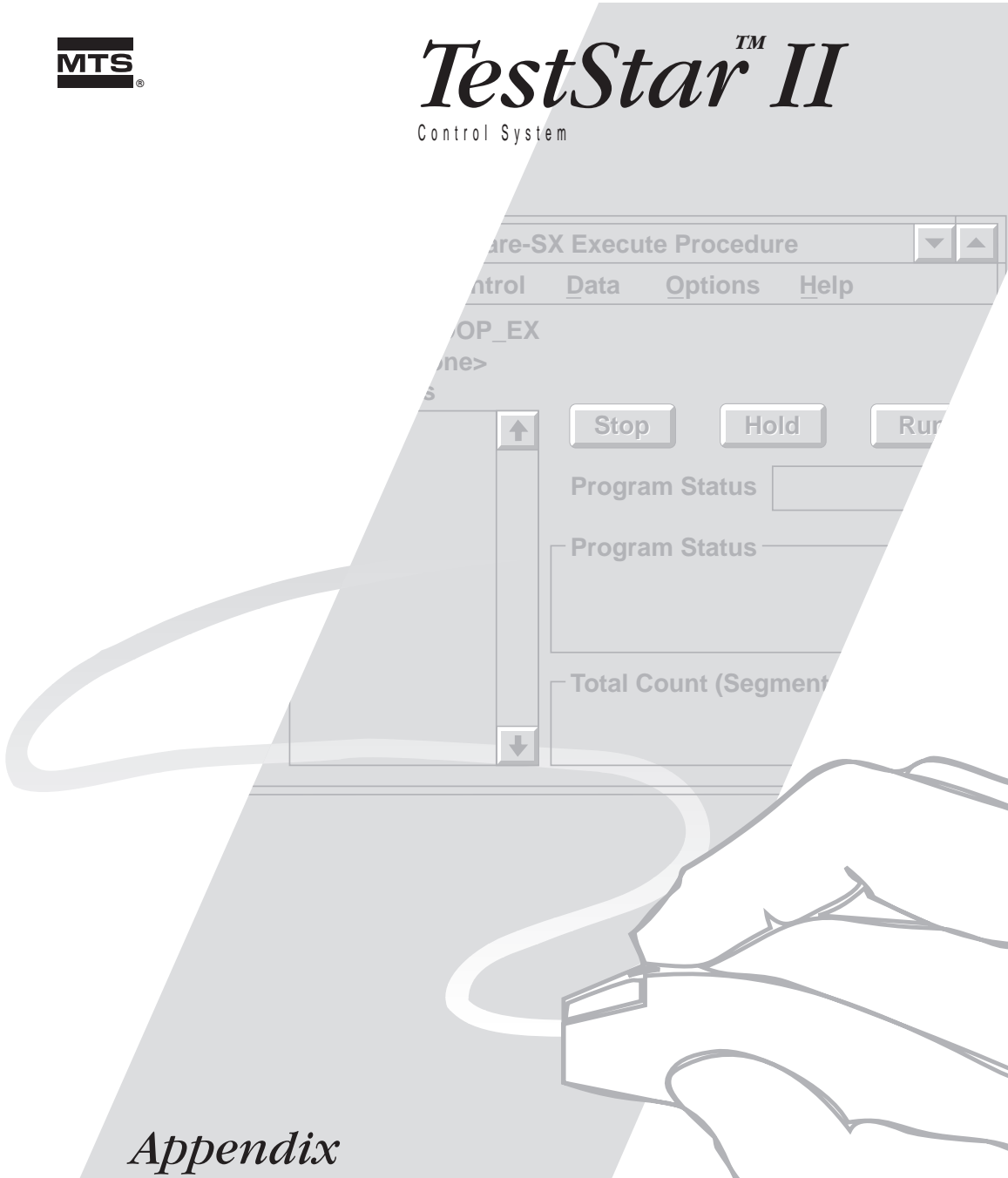

Appendix

Appendix

Contents

Appendix A: Firmware Error Codes 295

Lists the definitions of the error code numbers that can be returned when a firmware error occurs.

Appendix B: Digital Controller Error Codes 303

Lists the definitions of the error code numbers that can be returned when a digital controller error occurs.

Appendix C: Servo Loop Update Rate 309

Shows the current update rate and the maximum rate can be established.

Appendix D: Debug Options 311

Records the messages between the computer and digital controller.

Appendix E: Bypassing the Login 315

Describes how to bypass the login sequence for any TestStar program.

Appendix F: Load Path Stiffness Editor 317

Describes how to establish load path stiffness sets.

Appendix A

Firmware Error Codes

Following is a list of definitions of the numbers that are returned when a firmware error occurs. The type refers to the firmware object issuing the error.

Type acronyms

The following help describe the different types of firmware errors.

TYPE	DESCRIPTION
act	detector action events
aio	the analog input/output module
buf	data acquisition buffer on pprocessor module
cis	calculated input stream (calculated input error)
cmd	command (instructions pasted on from the hst to other parts of the digital controller)
dio	digital input/output (on the pprocessor module)
dly	delay
hio	hydraulic input/output module
hst	host interface (messages to/from the WSCI board)
ibc	instrumentation bus controller module
idp	
ilk	interlocks (processor module)
luc	load unit control panel;
mux	multiplex switching (processor module)
odp	output device (used for DAC's and valve drivers)
rom	remote object manager (keeps track of labels such as input signals, control channels, etc.)
rtc	real time clock
rtr	router (distributes messages within the transputer network)
Sgc	segment generator command

ERROR NO.	TYPE	DESCRIPTION
1	act	internal error unpacking parameters
2	act	selector not implemented
3	act	received selector for wrong class
4	act	received invalid destination oid
5	act	received invalid action type
6	act	received parameter out of range
7	aio	received selector for wrong class
8	aio	selector not implemented
9	aio	internal error unpacking parameters
10	aio	parameter out of range
11	aio	cannot alter running system
12	aio	channel cannot be selected
13	aio	excitation over range - reset to max
14	aio	excitation under range - reset to min
15	aio	error writing data to mux object
16	aio	invalid address for desired function
17	aio	undefined register setting detected
18	buf	received selector for wrong class
19	buf	selector not implemented
20	buf	internal error unpacking parameters
21	buf	parameter out of range
22	buf	no data is available in the buffer
23	buf	no buffers are available
24	buf	channel is not connected
25	buf	out of buffer data
26	buf	couldn't find class from object id
27	buf	specified event is not defined
28	cis	internal error unpacking parameters
29	cis	selector not implemented
30	cis	received selector for wrong class

ERROR NO.	TYPE	DESCRIPTION
31	cis	index id out of range
32	cmd	error packing interpreted command
33	cmd	timeout; object not created
34	cmd	object responded with incorrect class
35	cmd	rtr config error wrong oid responded
36	cmd	invalid parameter
37	cmd	object already exists
38	cmd	not enough parameters supplied
39	cmd	BYTE parameter out of range
40	cmd	error converting BYTE parameter
41	cmd	error converting INT16 parameter
42	cmd	error converting INT32 parameter
43	cmd	error converting INT64 parameter
44	cmd	too many parameters supplied
45	cmd	error converting REAL32 parameter
46	cmd	error converting REAL64 parameter
47	cmd	error in selector syntax
48	cmd	error in name syntax
49	cmd	selector for class not found
50	cmd	object does not exist
51	cmd	selector out of range
52	cmd	selector not implemented
53	cmd	coding error - vector parameter must be alone
54	cmd	received selector for wrong class
55	dio	internal error unpacking parameters
56	dio	parameter out of range
57	dio	selector not implemented
58	dio	received selector for wrong class
59	dio	received error from external obj
60	dio	selector out of range
61	dly	received selector for wrong class
62	dly	selector not implemented

ERROR No.	TYPE	DESCRIPTION
63	dly	internal error unpacking parameters
64	dly	parameter out of range
65	dly	couldn't find class from object id
66	dly	specified event is not defined
67	hio	internal error unpacking parameters
68	hio	invalid source for command
69	hio	invalid key command for HIO
70	hio	sel not implemented
71	hio	received selector for wrong class
72	hio	received invalid channel number
73	hio	can't change connection to event
74	hio	can't find class for oid
75	hio	proportional valve range error
76	hio	input parameter value error
77	hio	approval Timeout
78	hio	rcv override on command
79	hio	rcv override off command
80	hio	rcv low command
81	hio	rcv high command
82	hio	rcv off command
83	hst	received selector for wrong class
84	hst	selector not implemented
85	?hst	null msg received
86	?hst	message too long
87	ibc	received selector for wrong class
88	ibc	selector not implemented
89	ibc	internal error unpacking parameters
90	ibc	parameter out of range
91	ibc	timeout addressing register
92	ibc	invalid address for desired function
93	idp	received selector for wrong class

ERROR NO.	TYPE	DESCRIPTION
94	idp	selector not implemented
95	idp	internal error unpacking parameters
96	idp	parameter out of range
97	idp	timeout addressing register
98	idp	slot is not occupied by a conditioner
99	idp	unexpected response
100	idp	defined slot does not match hardware
101	idp	invalid slot def--UND=0;AC=1;DC=2;EXT=3
102	idp	invalid range
103	idp	conditioner type is not defined
104	idp	error scaling sgc or mux
105	idp	error sending AD polarity to mux
106	idp	time out waiting for mux or sgc resp
107	idp	internal error packing parameters
108	idp	invalid selector for extended AIO chan
109	idp	error locking mux for range change
110	ilk	internal error unpacking parameters
111	ilk	selector not implemented
112	ilk	received selector for wrong class
113	luc	internal error unpacking parameters
114	luc	sel not implemented
115	luc	received selector for wrong class
116	luc	parameter out of range(time)
117	luc	parameter out of range(key)
118	luc	parameter out of range
119	luc	parameter out of range(module id)
120	mux	received selector for wrong class
121	mux	selector not implemented
122	mux	internal error unpacking parameters
123	mux	parameter out of range
124	mux	couldn't find class from object id
125	mux	specified event is not defined

ERROR No.	TYPE	DESCRIPTION
126	mux	specified channel does not adjust cal
127	odp	received selector for wrong class
128	odp	selector not implemented
129	odp	internal error unpacking parameters
130	odp	parameter out of range
131	odp	timeout addressing register
132	odp	invalid address for desired function
133	odp	slot is not occupied by a valve driver
134	odp	unexpected response
135	rom	internal error unpacking parameters
136	rom	oid already allocated for object specified
137	rom	out of oids to allocate
138	rom	cannot deallocate a connected object
139	rom	object not allocated
140	rom	object already connected
141	rom	object name not found (allocated)
142	rom	state var index out of range
143	rom	object currently in allocated state
144	rom	invalid object ID
145	rom	selector not implemented
146	rom	received selector for wrong class
147	rtc	internal error unpacking parameters
148	rtc	rate is too slow for current base frequency
149	rtc	selector not implemented
150	rtc	received selector for wrong class
151	rtc	not a valid range selector
152	rtr	object not connected
153	rtr	I don't do common selectors!
154	rtr	selector not implemented
155	rtr	received selector for wrong class
156	Sgc	no error

ERROR NO.	TYPE	DESCRIPTION
157	Sgc	invalid mode index
158	Sgc	invalid controller type
159	Sgc	invalid command index
160	Sgc	invalid feedback index
161	Sgc	params> commandfeedbackcontrolintegrator
162	Sgc	shapes> 0-step 1-ramp 2-sin 3-aux
163	Sgc	clock rate must be faster than 10 Hz
164	Sgc	must be stopped for immediate call
165	Sgc	message unpacking error
166	Sgc	Internal Error - invalid state
167	Sgc	current count > preset count
168	Sgc	must be in hold state to change modes
169	Sgc	selector not implemented
170	Sgc	received selector for wrong class
171	Sgc	Internal Error; Invalid feedback mode
172	Sgc	integrator states > off(0) on(1)
173	Sgc	Internal Error; Invalid integrator state
174	Sgc	message packing error
175	Sgc	error limit states > off(0) on(1)
176	Sgc	last arb not fully defined
177	Sgc	arb buffer overrun
178	Sgc	seg buffer overrun
179	Sgc	define new arb for current segment
180	Sgc	aux shape table overrun
181	Sgc	aux shape must start at 00
182	Sgc	aux shape must end at 10
183	Sgc	must be in hold state to reset aux table
184	Sgc	aux shape table not filled
185	Sgc	Arb queue is empty
186	Sgc	no error limits in Clc control mode
187	Sgc	error in event number
188	Sgc	no class id for dstOid

ERROR NO.	TYPE	DESCRIPTION
189	Sgc	mux scaling error
190	Sgc	mode error - command source must be SG
191	Sgc	range error for adScale
192	Sgc	must use extScale for Ext cmd source
193	Sgc	Clc command source must be Pod
194	Sgc	error getting event selector from dstOid
195	Sgc	must resetErrCheck before start
196	Sgc	$2 < \text{aux size} < 1025$
197	Sgc	$0 \leq \text{ampl convergernce rate} \leq 1$
198	Sgc	number of arb segments must be >0
199	Sgc	invalid command out path
200	Sgc	sac is being reset
201	Sgc	sac pos must be ≥ 0 and $< \text{SacSize}$
202	Sgc	invalid control channel limits (hi=lo)
203	Sgc	SAC table overrun
204	Sgc	clc low limit $>$ high limit
205	Sgc	locked by action event - must resetErrCheck /* LOCATION value defined 206 */
206	Sgc	next mode has control channel fault
207	Sgc	control channel not enabled
208	smp	received selector for wrong class
209	smp	selector not implemented
210	smp	internal error unpacking parameters
211	smp	parameter out of range
212	smp	channel sample product exceeds 63
213	smp	couldn't find class from object id
214	smp	specified event is not defined
215	smp	channel list overrun
216	smp	can't reset while running

Appendix B

Digital Controller Error Codes

Following is a list of messages associated with the numbers that are returned when a digital controller error occurs.

ERROR NO	MESSAGE
0	NO_ERR
1001	MTSERR_FIRST_CONNECT
1002	MTSERR_PIPE_BROKEN
1003	MTSERR_BAD_PID
1004	MTSERR_PROCESS_CONNECTED
1005	MTSERR_MAX_CONNECTIONS
1006	MTSERR_BAD_PIPE_TYPE
1007	MTSERR_PIPE_CONNECTED
1008	MTSERR_PIPE_PARTIAL_WRITE
1009	MTSERR_NO_MEMORY
1010	MTSERR_BAD_RETURN
1011	MTSERR_PIPE_CLOSED
1012	MTSERR_Q_FULL
1013	MTSERR_WRITING_PID
1014	MTSERR_WRITING_PIPE_TYPE
1015	MTSERR_READ_TIMEOUT
1016	MTSERR_WRITE_TIMEOUT
1017	MTSERR_TIMEOUT
1018	MTSERR_CANNOT_OPEN_WSCI
1019	MTSERR_FILE_NOT_FOUND
1020	MTSERR_FIRMWARE_BAD_DOWNLOAD
1021	MTSERR_CONNECT_HIO_POD
1022	MTSERR_UNKNOWN_COMMAND
1023	MTSERR_UNKNOWN_FIRMWARE_ERROR
1024	MTSERR_UNAVAILABLE_RESOURCES
1025	MTSERR_CANNOT_CREATE_MQ
1026	MTSERR_CANNOT_CREATE_RQ
1027	MTSERR_NO_SUCH_LINK

ERROR NO	MESSAGE
1028	MTSERR_LINK_NUM_OUT_OF_RANGE
1029	MTSERR_MAX_CLASSES_EXCEEDED
1030	MTSERR_BAD_DIO_BIT
1031	MTSERR_UNKNOWN_POD_KEY
1032	MTSERR_TIMEOUT_CREATING
1033	MTSERR_TIMEOUT_FW_RESP
1034	MTSERR_BAD_INPUT_CHAN
1035	MTSERR_BAD_OUTPUT_CHAN
1036	MTSERR_PARAM_RANGE_ERR
1037	MTSERR_INITIALIZING_FW_OBJECTS
1038	MTSERR_NO_SYM_MATCH
1039	MTSERR_NO_INPUT_FILE
1040	MTSERR_SCALE_EQ_ZERO
1041	MTSERR_NO_DIM_MATCH
1042	MTSERR_IDS_NOT_EQUAL
1043	MTSERR_MONITOR_NOT_FOUND
1044	MTSERR_MAX_MONITORS
1045	MTSERR_MQ_PIPE_BROKEN
1046	MTSERR_CREATE_MQ_THREAD
1047	MTSERR_SETTING_MQ_PRIORITY
1048	MTSERR_MQ_NOT_STARTED
1049	MTSERR_READING_MQ
1050	MTSERR_RQ_NOT_STARTED
1051	MTSERR_BUFF_MONITOR_GET_BUFFER
1052	MTSERR_RAW_WRITE
1053	MTSERR_SGC_ARB_SIZE
1054	MTSERR_NO_CONTROLLER_LINK
1055	MTSERR_ILLEGAL_COMMAND
1056	MTSERR_SHAPE_SIZE
1057	MTSERR_SGC_BINARB_SIZE
1058	MTSERR_RAW_WRITE_RSP
1059	MTSERR_INTERNAL_ERROR
1060	MTSERR_GET_HEADER_OID_BOUNDS
1061	MTSERR_GET_OBJ_NAME_OID_BOUNDS
1062	MTSERR_CM_ALLOC_OID_BOUNDS
1063	MTSERR_CM_DEALLOC_OID_BOUNDS

ERROR NO	MESSAGE
1064	MTSERR_XPID_GET_OID_BOUNDS
1065	MTSERR_XPID_SET_USERPTR_BOUNDS
1066	MTSERR_XPID_GET_USERPTR_BOUNDS
1067	MTSERR_DUP_XPID_ALLOC_EXCEEDED
1068	MTSERR_PROCESS_LINK_FAIL
1069	MTSERR_OM_MAIN_FAIL
1070	MTSERR_DRP_INIT_FAIL
1071	MTSERR_GET_BUFFER_LINK_FAIL
1072	MTSERR_OM_WRITE_RAW_FAIL
1073	MTSERR OMXCR_INIT_FAIL
1074	MTSERR OMXCR_INSERT_FAIL
1075	MTSERR_ILLEGAL_XPID
1076	MTSERR_NO_INTERLOCK_OBJ
1077	MTSERR_CONNECTING_MUX_TO_POD
1078	MTSERR_XCR_BROADCAST
1079	MTSERR_INVALID_CONTROL_CHAN
1080	MTSERR_INVALID_CONTROL_MODE
1081	MTSERR_INVALID_INPUT_CHAN
1082	MTSERR_INVALID_OUTPUT_CHAN
1083	MTSERR_SGC_RESERVED
1084	MTSERR_NO_SGC_FOR_VALVE
1085	MTSERR_SGC_NO_PRIV
1086	MTSERR_CANNOT_OPEN_LOG
1087	MTSERR_NO_POD
1088	MTSERR_CANNOT_CONNECT_MQ_TO_OM
1089	MTSERR_CANNOT_CONNECT_RQ_TO_OM
1090	MTSERR_CANNOT_CONNECT_TO_ML
1091	MTSERR_NO_FW_INIT_RESP
1092	MTSERR_NO_CHAN_MAP
1093	MTSERR_TOO_MANY_SEGMENTS
1094	MTSERR_SGC_SYNCHED_ALREADY
1095	MTSERR_INTERNAL_BAD_SGC_POS
1096	MTSERR_TOO_MANY_UPK
1097	MTSERR_ILLEGAL_UPK
1098	MTSERR_SGC_NO_SKIP
1099	MTSERR_CONNECTION_BROKEN

ERROR NO	MESSAGE
1100	MTSERR_INTERNAL_PIPE_ERROR
1101	MTSERR_ZERO_RATE
1102	MTSERR_BAD_MESS_TAG
1103	MTSERR_COMMAND_FOR_MASTER_ONLY
1104	MTSERR_NO_PANE_AVAILABLE
1105	MTSERR_INCORRECT_BUF_TYPE
1106	MTSERR_INTERNAL_NO_BUF OBJ
1107	MTSERR_CHAN_ALREADY_CONNECTED
1108	MTSERR_INVALID_PANELID
1109	MTSERR_INVALID_RANGE
1110	MTSERR_PRINTER_ERROR
1111	MTSERR_FILE_OPEN_ERROR
1112	MTSERR_FILE_WRITE_ERROR
1113	MTSERR_FILE_READ_ERROR
1114	MTSERR_PROF_READ_ERROR
1115	MTSERR_TC_NOT_ENABLED
1116	MTSERR_TC_READ_WRITE
1117	MTSERR_TC_TEMP_RANGE
1118	MTSERR_TC_PORT_ERROR
1119	MTSERR_TC_NOT_INITIALIZED
1120	MTSERR_TC_INVALID_CHANNEL
1121	MTSERR_TC_CONV_ERROR
1122	MTSERR_TC_INVALID_DEVICE
1123	MTSERR_TC_NOT_REMOTE
1124	MTSERR_TC_INVALID_HANDLE
1125	MTSERR_TC_ALLOCATED
1126	MTSERR_TC_MONITO_NOT_DEFINED
1127	MTSERR_CALC_INVALID_EQUATION
1128	MTSERR_CALC_NOT_DEFINED
1129	MTSERR_CALC_PREV_NOT_DEFINED
1130	MTSERR_CALC_DEF_OUT_OF_ORDER
1131	MTSERR_CTRL_NOT_INITIALIZED
1132	MTSERR_CTRL_INUSE
1133	MTSERR_CTRL_DEF_DEFINED
1134	MTSERR_CTRL_DEF_ERROR
1135	MTSERR_INVALID_CTRL_CHAN_LABEL

ERROR NO	MESSAGE
1136	MTSERR_INVALID_CTRL_CHAN_NAME
1137	MTSERR_INVALID_INP_CHAN_TYPE
1138	MTSERR_INVALID_INP_CHAN_NAME
1139	MTSERR_INVALID_INP_CHAN_LABEL
1140	MTSERR_INVALID_CALC_CONST
1141	MTSERR_INVALID_CALC_CONST_NAME
1142	MTSERR_INVALID_OUTP_CHAN_TYPE
1143	MTSERR_INVALID_OUTP_CHAN_NAME
1144	MTSERR_INVALID_OUTP_CHAN_LABEL
1145	MTSERR_INVALID_CTRLMOD
1146	MTSERR_INVALID_CTRLMOD_CMDSRC
1147	MTSERR_INVALID_CTRLMOD_TYPE
1148	MTSERR_INVALID_CTRLMOD_NAME
1149	MTSERR_INVALID_CTRLMOD_LABEL
1150	MTSERR_CHAN_IN_USE_AS_FEEDBACK
1151	MTSERR_SGC_ACTION_INTERLOCK
1152	MTSERR_INVALID_CTRL_CHAN_TYPE
1153	MTSERR_TC_RAMP_RANGE
1154	MTSERR_LW_INVALID_FILE
1155	MTSERR_LW_INVALID_TYPE
1156	MTSERR_LW_INVALID_NUM_RANGES
1157	MTSERR_LW_INVALID_ENABLEBIT
1158	MTSERR_LW_INVALID_RANGE
1159	MTSERR_INVALID_COMPENSATOR
1160	MTSERR_INVALID_COMP_TYPE
1161	MTSERR_CANNOT_CREATE_DRQ
1162	MTSERR_DRQ_NOT_STARTED
1163	MTSERR_CANNOT_CONNECT_DRQ_TO_OM

Appendix C

Servo Loop Update Rate

The servo loop update rate shows how quickly the servo control loop can be updated. This represents the speed of the digital controller and limits the maximum frequency you can select for a test command.

When this window opens, the maximum update rate is displayed (factoring in the number of control channels, calculated inputs, and other things that can slow it down).

Use this window to check or change the servo loop update rate.

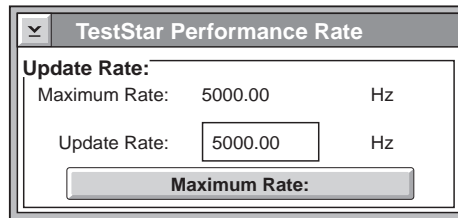

You can enter a value less than the maximum rate in the **Update Rate** entry field. Press the **Maximum Rate** pushbutton to return the update rate to the maximum value possible.

Accessing the window

Access to the Performance Rate window is accomplished with the TestStar toolbar or the hotkey combination.

Press **cntl + u**



Go to the Edit Toolbar window if you want to access this window with a toolbar button.

Things that slow TestStar down

servo loop update rate

TestStar has a number of features that can slow down the servo loop update rate. The number of features you use determines what the maximum servo loop update rate can be.

The following slow down the servo loop update rate:

- ◆ Each control channel reduces the servo loop update rate. The software installation program specifies the number of control channels available.

For example, assume you have a biaxial system and are running a single axis test. Since have no need for the extra control channel, select none for the Drive Type in the Edit Control Channels table.

- ◆ Each calculated input signal reduces the servo loop update rate. The complexity of the calculation determines how much the input signal reduces the update rate.
- ◆ The type of processor module installed in TestStar can affect the servo loop update rate. The new, T805 processor increases the servo loop update rate.

You have the T805 processor if the calculated input signals can be selected in the Edit Input Signals window.

- ◆ Some TestWare applications have features that slow down the servo loop update rate. See the appropriate product manual.

computer processing rate

The following don't affect the servo loop update rate but do slow down the processing rate of the computer. This affects the communications with the digital controller and slows the data exchange rate between the digital controller and the computer.

- ◆ Each digital scope requires processing time.
 - ◆ Each meter requires processing time. Disable any meter that is not needed (Edit Meter window).
 - ◆ The display of the load unit control panel uses processing time. This can be disabled in the Debug Options window.
 - ◆ Using the message log feature in the Debug Options window slows down the computer communications.
-

Appendix D

Debug Options

Accessing the window



If you encounter a problem, you can view the activity between the computer and the digital controller. You can also record the activity to a file. This file can be used by MTS to evaluate the communication between your computer and digital controller.

Access to the Debug window is accomplished with the TestStar toolbar or a hotkey combination. Go to the Edit Toolbar window if you want to access this window with a toolbar button.

Press **ctrl + d**

The computer translates your selections in the TestStar windows and sends messages to the TestStar digital controller. The messages configure the digital controller to act on your selections. The digital controller in turn sends messages to the computer which performs tasks like updating values, showing the results of a selection, etc.

For example, assume you are setting up the command in the Function Generator and you forget to enter the initial ramp rate. When you try to close the window, a dialog box displays the message:

Initial ramp rate is out of range. Valid range: [0 < value]

What is happening is: for each selection you make in the window, a message is sent to the TestStar digital controller. Since a zero rate is invalid, the controller returns the error message #1101 MTSERR.ZERO.RATE. The computer translates the message and displays the dialog box.

The debug feature allows knowledgeable programmers access to the sequence of message strings to and from the digital controller.

Error codes

If you encounter an error code and wish to know what it means, see Appendix A and B. Appendix A identifies firmware error codes (codes 1 - 999) and Appendix B identifies digital controller error codes (codes 1001 - 1200).



Debug Options Window

Use the Debug Options window to record TestStar activity.

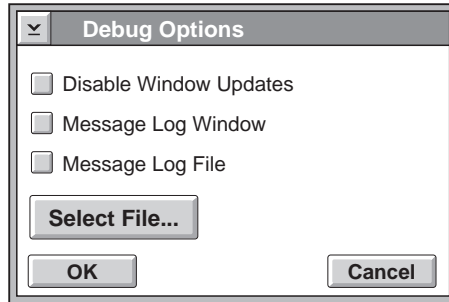

CONTROL	FUNCTION
Disable Window Updates	Disables the display located on the load unit control panel. The LUC remains functional except for the display.
Message Log Window	Displays a window that shows the activity between your computer and the digital controller.
Message Log File	Creates a file (C:\TS\mess.log) of the activity between your computer and the digital controller.
Select File	Displays the Select Output Log File window. Use this window to create a log file (use a .LOG extension) or to overwrite an existing file.

Select Output Log File Window

Use this window to create a TestStar log file or overwrite an existing log file.

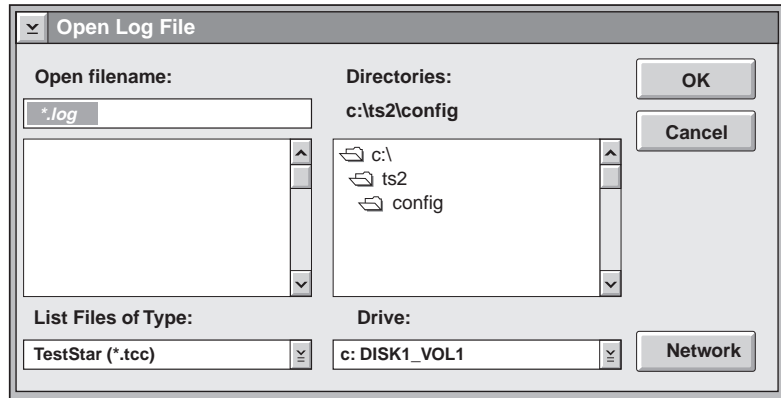

Note The default path for this window is the TestStar directory path (C:ITS2) your path may be different.

CONTROL	FUNCTION
Open filename	Displays *.LOG in the entry field. Type the name you want to call the configuration file here.
<i>files</i>	Lists the log files in the current directory. Selecting a file name displays it in the File Name entry field.
List Files of Type	Selects the type of files displayed in the File list. By default, <All Files> is selected. Select file type *.LOG to display only the files with the .LOG extension in the Files list.
Directories	Lists the available directories for the selected drive. Double-clicking a different directory displays the files of the directory in the Files list and any other directories in the Directories list.
Drive	Displays the current drive. All root directories of the drive are listed in the Directories list.
Network	Pressing the Network button displays the Connect Network Drive window where you can define new network drives and paths.

Using the window

Be sure you know where you save your debug log files.

For example, assume you created a directory called Log in the TS directory of the C: drive, and you save your debug log files in that directory.

1. Use the list icon for the Drive field to select the drive where your configuration files are located.

In this case the C: drive should already be displayed.

2. Double-click the desired directory in the Directory list, this causes its files to be displayed in the Files list and it also displays any additional directories.

In this case TS should be displayed, double-click the Log directory you created.

3. Select the TestStar configuration file you want to open from the File list. The selection will be displayed in the Open filename field.

Otherwise, enter a new file name and a new log file will be created.

4. Press the OK pushbutton to open the file.
-

Appendix E

Bypassing the Login

If you want, you can configure any TestStar program to open without logging in. This is required if you want to open TestStar by double-clicking a configuration file.

⚠ CAUTION

Bypassing the login lets anyone use TestStar.

If you are concerned about unauthorized access to your configuration files, DO NOT bypass the TestStar login sequence.

Bypassing the login

The following procedure describes how to bypass the Login window:

- A** Select a TestStar program (but do not open it).
- B** From the Program Manager File menu, select New.
- C** Select Program Item in the New Program Object window and press the OK button.
- D** Add the mts mts parameters to the end of the path and file name in the Command Line entry field.

Repeat steps A - D for any TestStar program.

Here, the settings file opens the Function Generator using the default MTS user name and password.

DO NOT change the Path and File Name or the Working Directory entries.

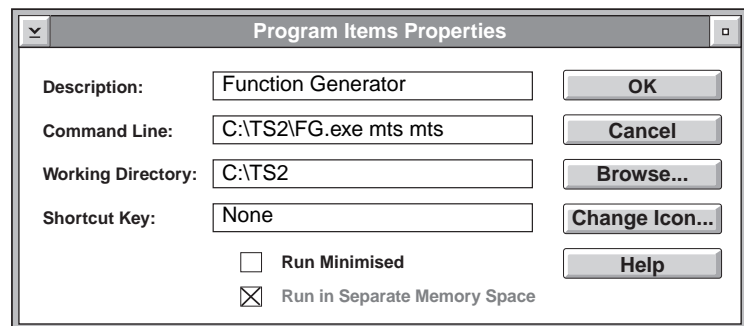

Appendix F

Load Path Stiffness Editor

The Load Path Stiffness Editor creates sets of values that compensate for deflection in the load path. Use the Load Path Stiffness Editor to create a stiffness set for each configuration of the load path.

Note *The stiffness sets created by the Load Path Stiffness Editor are used by the 790.3x processes only.*

Prerequisites

TestStar must be running before you can start the Load Path Stiffness Editor. You should also have determined a stiffness values as in this appendix.

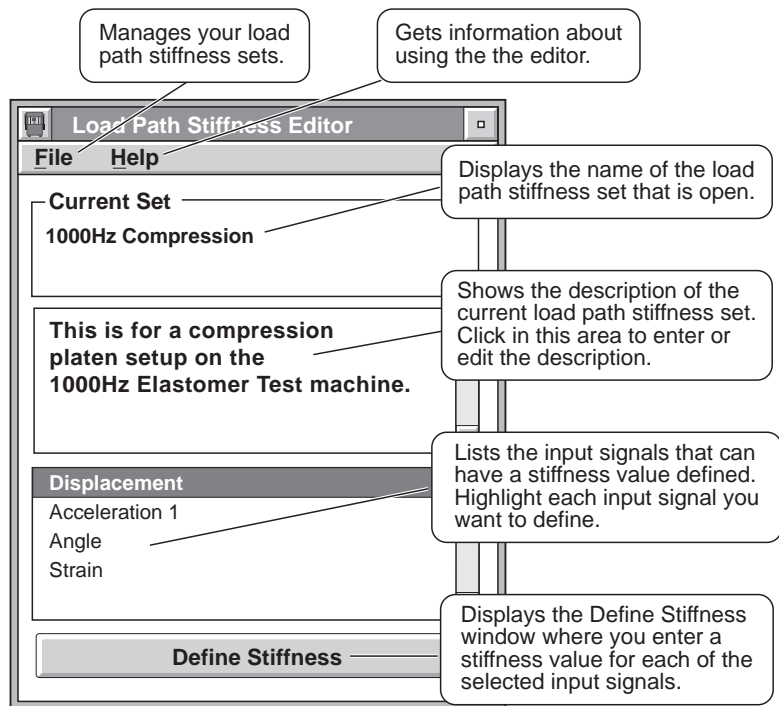

File menu Use the File menu to manage your load path stiffness sets.

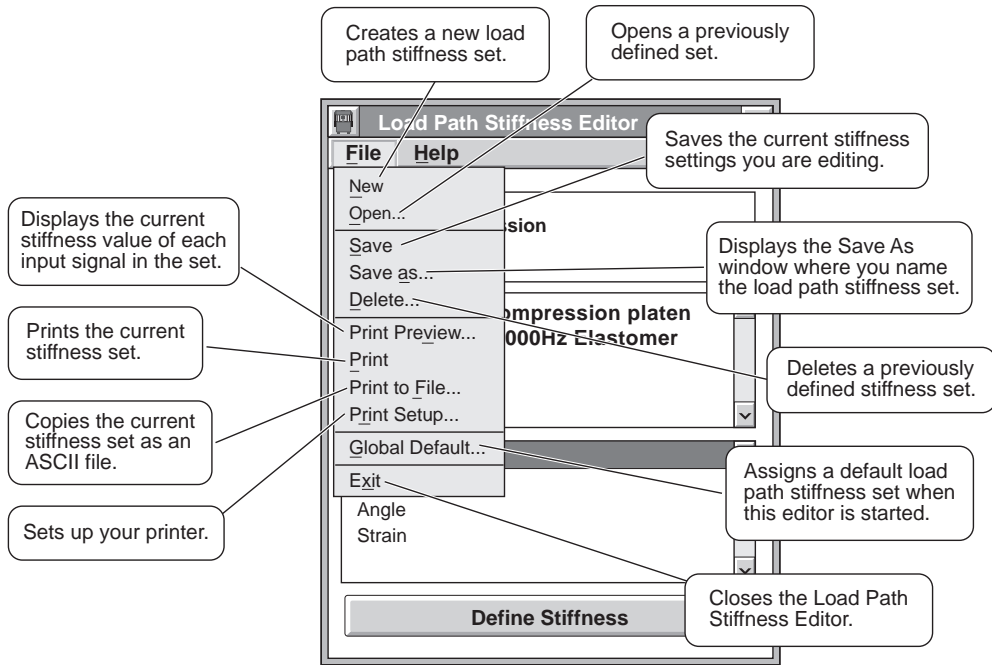

How it works

The load path stiffness parameters compensate for the amount of deflection that is produced from the actuator, through the grips, extension rods, load cell, and load frame (everything in the load path except the specimen). All of these components act together as the load path.

The load path stiffness editor defines a set of stiffness values for the displacement sensors and saves it in a data base. A stiffness set consists of stiffness values for an LVDT, accelerometer and in some cases, an ATD. Any unique combination of the components of the load path should have a stiffness set defined for them.

For example, assume you have a system that uses compression platens with extension rods (to accommodate a temperature chamber) for one type of test. For another type of test you use the compression platens without the extension rods. You should create a stiffness set for both types of tests

Using the Load Path Stiffness Editor

This procedure describes how to use the Load Path Stiffness Editor to create a stiffness set.

1. Determine stiffness values 319
 2. Open the Load Path Stiffness Editor 320
 3. Create a new stiffness set 321
 4. Close the Load Path Stiffness Editor 321
-

Step 1 Determine stiffness values

The following is a guideline to determine the stiffness value for an axis.

Note *Be sure to have the load path configured with components needed for the test.*

Create a test command program that produces a slow ramp (one minute) over the range of the force sensor.

- ◆ Acquire force and displacement data.
- ◆ Use a stiff specimen such as steel.
- ◆ Calculate the stiffness from the force and displacement data.

The load path stiffness value is expressed as force unit/displacement units.

The acquired data can be used with a spread sheet application to calculate the stiffness value (or slope of the data)

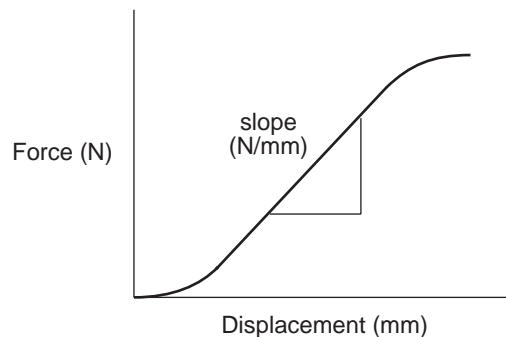

Step 2 Open the Load Path Stiffness Editor

- A Double-click the MTS-TSII icon on the OS/2 desktop. (OS/2 only) Then double-click the Utility folder.
- B Double-click the Load Path Stiffness Editor icon.
- C You may need to log into the Load Path Stiffness Editor. Enter your user name and password in the MTS Login window.

The Load Path Stiffness Editor is located in Utility folder of the MTS-TSII folder.

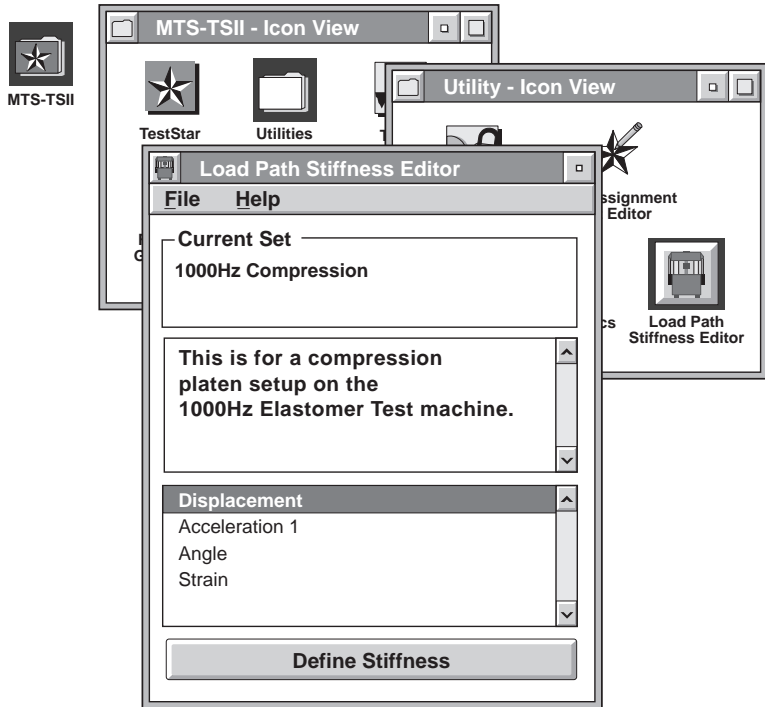

Step 3 Create a new stiffness set

Perform the following to initiate a new load path stiffness set.

- A** Select New in the File menu.
- B** Type a description for the stiffness set in the entry area of the Load Path Stiffness Editor window.
- C** Highlight each input signals that will have a correction value (only sensors that can measure displacement are listed).
- D** Press the Define Stiffness pushbutton to display the Define Stiffness window.

Use this window to enter the stiffness values.

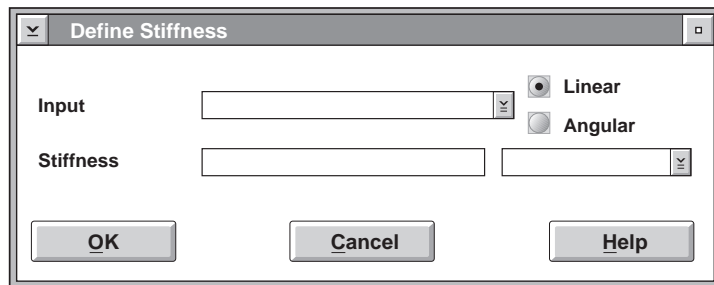

- E** Select an input signal in the Define Stiffness window. If you select a strain signal, select the appropriate Linear/Angular dimension for the stiffness units.
- F** Select the stiffness units then enter the stiffness value.
- G** Repeat steps E and F for each input signal selected in step C.
- H** Press OK in the Define Stiffness window.

Step 4 Close the Load Path Stiffness Editor

Select Save As in the File menu. Type a name for the stiffness set in the entry field and Press OK. Then close the program by double-clicking the system menu icon (upper left corner of the window).

Index

A

Abbreviations 45
Acceleration compensation 155
Actions
 correcting 54
 defining 124
 edit window 126
 fault status 125
 hold 127
 ramp and hold 128
 standard 124, 126
Actuator Positioning Control 66
Adjust 256/257 Valve window 184
Adjust drive 180
Adjust menu
 error detectors 174
 underpeak 177
Adjusting controls
 inadequate adjustment 270
Administrator (see system administration)# 240
Amplitude
 adjustment 206, 227
 compensation methods 171, 219
 control
 & mean control 170
 convergence rate 172
 how it works 209
 ramp rate 215
 ramp time 219
 scroll range 212
Amplitude ramp time
 218
Auto tuning 115
Auto zero 191
 adjustment range 156
 using 152
Auto-tuning 160, 163
Auto-tuning control mode 283
Avoiding hazardous actuator movement 17

B

Base control mode 115
Before you call 27

C

Calculated Input signals
 defining 93
 examples 95
 functions 94
Calculation constants 122
CASC
 block diagram 168
Cascade control mode 167
Caution symbol 25
Channel limited channel 164
 changing adjustment range 165
 example 166
 how it works 165
 tuning 166
Clearing a detector action 54
Clearing an interlock 56
Command
 amplitudeCommand
 initial ramp rate 215
 compensation circuits 215
 defining 216, 226
 external 218
 initial ramp rate 215
 waveforms 215
 window 214
Command source 119
Compensators 170, 171
Compensators
 219
Configuration file 50
 default 51
 folder 315
 format 78
 opening 73
 saving 75

- username 51
- Configuration files 236
- Contacting MTS 26
- Continuous cycle 226
- Control channels 110
 - 252 valve adjustments 181
 - 256/257 valve adjustments 184
 - adjusting dither 182
 - adjusting valve balance 182
 - connections 110
 - defining 112
 - definition 114
 - drive types 115
 - drive window 181, 184
 - drives 111
 - modules 66
 - underpeak detector 177
 - valve adjustments 180
 - window 112
 - LUC 66
- Control modes 116
 - auto tuning 115
 - auto-tuning 160
 - base 283
 - cascade 116
 - Cascade (CASC) 121
 - channel limited channel 116
 - CLC 120
 - command source 119
 - max number 159
 - PIDF 116, 118
 - tune CASC 167
 - tune CLC 164
 - tune PIDF 161
 - types 116, 160
- Convergence rate 172
- Creating user names 240
- Crush point hazards 16
- Current output 190
- Customer-defined actions 124
- Cycle counter 220
 - continuous cycling 220
 - defining 226
 - how it works 221
 - preset count 221
- span/mean data 140
- timed data 138, 139
- Debug 311
- Debug file 313
- Defaults
 - configuration file 241
- Defining
 - calculated signals 93
 - calculation constants 122
 - control channels 110
 - control mod 120
 - control mode 118, 121
 - control modes 116
 - detector actions 124
 - input signals 85
 - load path stiffness sets 319
 - LUCP display 131
 - meters 136
 - output signals 99
 - scope 142
 - toolbar 133
- Detector actions 124
- Detectors
 - display error action 194
 - display limits 194
 - display underpeak action 194
 - display window 193
- Digital controller error codes B 303
- Digital scope 280
- Display
 - detector actions 193
 - input signals 190
 - load unit control panel 131
 - load unit control panel Defining
 - LUCP display 131
 - menu 189
 - meters 136, 196
 - scope 142
 - screen 64
- Dither
 - adjusting amplitude 182
 - adjusting frequency 183
 - amplitude 181, 184
 - frequency
 - 252 servovalve 181
 - 256/257 servovalve 184
- Drive types 115

D

- Data display
 - max/min data 141

E

Edit User window 235
 Electro mechanical systems 180
 E-mail 26
 Emergency Stop switch 62
 EPO switch 62
 Error codes 311
 digital 303
 firmware 295
 Error Detector
 how it works 175
 Error detector
 actions 176
 causes 55
 using the window 176
 Error signal 279
 External command source
 defining ramp amplitude 219
 function generator 218
 External sensor
 define temporary 97
 defining 92
 how it works 92
 offsetting input 98

F

Fault status display 56
 Fault Status window 52
 Fax number 26
 Feedback safety precaution 17
 File extension
 configuration file (.TCC) 50
 debug log (.LOG) 313
 Firmware error codes 295
 Following 295
 Force sensor
 acceleration compensation 155
 Frequency
 adjustment 206, 227
 how it works 210
 scroll range 213
 Full scale 154
 Function Generator 205
 Function generator
 amplitude
 how it works 209

 ramping 219
 set scroll range 212
 amplitude/mean control 219
 command 214
 controls 206
 counter 220
 continuous cycling 220
 how it counts 221
 preset count 221
 designing a test 224
 external command 218
 frequency 210
 frequency adjustment range 213
 home ramp 222
 controls 222
 how it works 222, 223
 how it works 216
 mean control range 211
 mean level 208
 opening 225
 phase/amplitude control 219
 prerequisites 205
 programming 207, 224
 return to zero 223
 status 210
 test requirements 224
 using the window 207
 waveform components 216
 window 206
 Function Generator Top 62

G

General safety guidelines 12

H

Hazard conventions 25
 Help 26
 calling for 60
 calling for re 1- 60
 introduction 59
 menu 59
 window 60
 HELpline 27
 Hold actions 127
 Hold switch 62
 Hold swith 62

- Home ramp 222
- How information is arranged 34
- How to
 - contact MTS 26
 - troubleshoot 27
- How to use this manual 34
- HPS control switches 63
- HPS Switches
 - 63
- Hydraulic
 - systems 180
- Hydraulic
 - HPS pressure control 63
 - service manifold control 66

I

- Input signals 148
 - ac conditioner 90
 - acceleration compensation 155
 - adjusting 149
 - assigning 96
 - calculated signals 93
 - calibration 86
 - conditioners 90
 - connection 86
 - current output 190
 - dc conditioner 90
 - defining external 97
 - display 190
 - display limitations 191
 - label 89
 - naming 89
 - range 192
 - ranges 154
 - sensor cartridge 87
 - sensor signals 88
 - sensor zero 152
 - shunt cal 157
 - signal definition 88
 - type of sensors 85
 - upper and lower limits 151
 - what you need to know 148
 - zero 191
- Interlock
 - actions 176
 - Actions 179
 - causes 57
 - correcting 56, 58
 - Emergency Stop 62
 - fault status window 52, 56
 - indicators 56, 63
 - overview 53
 - possible causes 56
 - resetting 52, 58
 - table 57
 - types 57
- Interlock
 - Reset switch 63
- Internet address 26

K

- Keyboard shortcuts 37
 - debug options 311
 - servo loop update rate 309

L

- LCD
 - where used 64
- Limit
 - actions 53
- Limit detector
 - actions 152, 195
 - causes 55
 - sensor 151
 - setting 151
 - unknown levels 151
- Load path stiffness 129
- Load Path Stiffness Editor 317
 - defining sets 319
 - determining a stiffness value 319
- Load unit control panel 61
 - configurations 67
 - defining display 131
 - Emergency Stop switch 62
 - HSM control switches 66
 - modules 66
 - test control switches 62
- Load unit control panel
 - actuator positioning control 66
 - display screen 64
 - HPS control switches 63
 - interlock indicators 63
 - Reset switch 63
 - test control switches 62
- Logging in 48, 232, 315

Login—bypassing 315
LUC Positioning Hint 66

M

Maintenance 23
Manual
 how information is arranged 34
 how to use 9, 34
 other manuals 10
Max/Min data 141
Mean
 & amplitude control 219
 adjustment 206, 227
 how it works 208
 scroll range 211
Message log 311
Meters
 alignment menu 197
 control menu 197
 defining 137
 display 196
 max/min data 141
 span/mean data 140
 timed data 138, 139
 types 136, 196
Modifications 21
Mouse 37
MTS technical assistance 26

O

Obtaining technical assistance 26
Oscilloscope 280
Output signals
 analog bus 103
 sensor signals 104
 valve signals 104
 connecting 100
 connections 102
 defining 101
 external devices 99
 programmable 109
 readout 105
 offset examples 108
 scaling examples 107
Overview
 tuning 260

Overview
 interlock 63

P

PAC 171, 219
PAC adjustments 170
Password 241
Peak/Valley
 compensation adjustments 170
Performance rate 309
Phase/amplitude compensation
 convergence rate 172
 limit adjustment 173
PID control mode 161
Pod Display 64
Preferences
 configuration file 231
 unit assignment set 256
 units 254
Printing
 configuration file format 78
 scope display 199
Programmable output 109

R

Ramp actions 128
Range 98, 192
 full-scale 154, 192
 internal sensor 154, 192
 selecting 154, 192
Readout
 connectors 102
 signal
 gain 106
 offset 108
 scaling examples 107
Reset switch 63
Return to zero 223
Run/Resume switch 62
Run/Resume switch 62

S

Safety

- guidelines while operating equipment 15
- precautions 11
- Scope 142, 198
 - axis adjustment range 200
 - control menu 199
 - display 198
 - display colors 201
 - file menu 199
 - printing display 199
 - scaling an axis 198, 200
 - selecting colors 201
 - set scroll range 200
 - tuning notes 280
- Sensor
 - assign window 96
 - calculated 93
 - conditioners 90
 - define temporary 97
 - full-scale 154, 192
 - internal 90
 - limit actions 53, 152, 195
 - limits 151
 - range 154, 192
 - sensor cartridge 87
 - temporary 97
 - types 85
 - zero 152
- Sensor Zero
 - using 154
- Sensor zero
 - using 152
- Sensors
 - zero 191
- Servo loop
 - things that slow it down 310
 - update rate 309
- Servomotors 180
- Servovalve
 - adjusting dither 182
 - adjusting valve balance 182
 - adjustment procedure 276
 - connection 110
 - dither 184
 - Series 252 control 181
 - Series 256/257 controls 184
 - types 115
- Servo valves 180
- Set Scroll Range window
 - amplitude 212
 - auto zero 156
 - frequency 213
 - mean 211
 - scope 200
 - tuning controls 169
- SG command 265
- Shunt calibration 153
 - checking 157
 - how it works 158
 - information window 157
 - value 157
- Software
 - introduction 46
 - version 59, 78
- Span/Mean data 140
- Specimen
 - installation 19
- Stiffness 129, 317
- Stop switch 62
- Stop switch 62
- Stopping the test 62, 63
- Stopping the test 62
- Stopping the test 63
- Supervising the System 22
- Switches
 - Actuator Positioning Control 66
 - Emergency Stop 62
 - Hold 62
 - Run/Resume 62
 - Test control
 - Switches
 - Stop 62
- Switches
 - Hold 62
 - hydraulic power supply 63
 - hydraulic service manifold 66
 - Run/Resume 62
 - Stop 62
 - Test control 62
- System Administration 231
 - applications window 234
 - adding an application 238
 - assigning applications 237
 - assigning users 239
 - deleting an application 234
 - editing an application 238
 - configuration files 236
 - usernames 231
 - users window 234
 - adding a user 235
 - configuration file 236
 - deleting a user 234
 - editing a user 235
 - how it works 236
 - unit assignment 236
- System administration
 - application access 242

defining users 240
opening 240

T

Technical assistance 26
Telephone number 26
Telex number 26
Temporary sensor
 prerequisite 97
 window 97
Test
 control switches 62
TestStar
 configuration files 50
 debug options 312
 main window 49
 things that slow it down 310
TestStar
 starting 48
The 224, 235
This 9
Timed data 138, 139
Toolbar
 buttons 133
 configuring 135
Tuning 159
 about 260
 about the controls 270
 adjusting something wrong 261
 amplitude 275
 auto 163
 automatic 281
 auto-tune 283
 auto-tuning 285
 CASC
 block diagram 168
 defining 121
 tuning changing adjustment range 167
 tuning guideline 168
 CASC control mode 269
 checklist 262
 CLC
 defining 120
 how it works 165
 tuning guideline 166
 CLC control mode 268
 command sources 265
 control modes 265
 controls adjustment range 169

 creating a program 274
 displacement 283
 dummy specimens 277
 Ext command 265
 feed forward 273
 frequency 275
 haversine waveform 275
 if you've never tuned 261
 inadequate adjustment 270
 monitoring waveforms 278
 optimizing 264
 overview 260
 PIDF
 adjustment range 162
 defining 118
 tuning guideline 162
 Pod command 265
 procedure 288
 rate derivative 271
 reset integration 272
 saving parameters 261
 SG command 265
 sine waveform 275
 square waveform 274
 triangle waveform 274
 waveform 274
 what to do first 263
 when to tune 262
tuning waveforms 260

U

Underpeak detector
 actions 179
 causes 55
 controls 177
 how it works 178
 max/min definition 179
Underpeak detectors 177
Unit Assignment Set Editor 245
 assign default unit set 253
 defining 254
 dimension list 247
 file menu 249
 open unit 250
 opening 254
 save unit set 251
 standard sets 247
 units 245
Units

- creating preferences 254
- default 246
- definition 245
- dimensions 247
- preferences 254
- sets 245
- Use 251
- Username 231
 - configuration file 51
 - defining 241
- Using a mouse 37
- Using an oscilloscope 280
- Using on-line help 59
- Using sensors 88
- Using the digital scope 280
- Using the keyboard 37

V

- Valve balance
 - adjustment procedure 182, 276
- Valve driver 115

W

- Warning symbol 25
- Waveforms (see com-mand 215)
- When to tune 262
- Window controls 37
 - dialog box 44
 - menu bar 39
 - selecting 38
 - title bar 38
- Windows
 - Adjust Compensators 170
 - Adjust Drive (252) 181
 - Adjust Drive (256/257) 184
 - Adjust Input Signals 149
 - Adjust Tuning
 - CASC 167
 - CLC 164
 - PIDF 161
 - Adjust Underpeak Detectors 177
 - Application Access 237
 - Assign Sensor 90, 92, 96
 - Calculation Constants 122
 - Command Menu Options 214
 - Configure Toolbar 134

- Count Menu Option 220
- Debug Options 312
- Define External Sensor 92
- Display Detector Actions 193
- Display Input Signals 190
- Display Meter 196
- Display Scope 198
- Edit Application 238
- Edit Control Channels 112
 - Cascade 121
 - CLC 120
 - PIDF 118
- Edit Detector Actions 126
 - hold actions 127
 - ramp actions 128
- Edit Input Signals 88
 - ac/dc conditioner 90
 - calculated 93
- Edit Load Path Stiffness 130
- Edit LUCP Display 131
- Edit Meters 137
 - max/min 141
 - span/mean 140
 - timed 138, 139
- Edit Output Signals 101
 - analog bus 103
 - programmable 109
 - readout 105
- Edit Scop 142
- Edit User 235
- Fault Status 52, 125
- fault status 52
- Font Fonts 76
- Function Generator 206
- Home Menu Option 222
- Load Path Stiffness Editor 317
- Login 48
- New Application 238
- New User 235
- Open configuration 72
- performance rate 309
- Print Preview Printing
 - configuration file Configuration file
 - preview Configuration file
 - ASCII 77
- Save configuration 74
- Scope Display Options 201
- Select Output Log File 313
- Set Amplitude Scroll Range 212
- Set Frequency Scroll Range 213
- Set Mean Scroll Range 211
- Set Scope Axis Scroll Range 200

Set Scroll Range 169
Set Zero Scroll Range 156
Shunt Cal 157
System Administration 233
TestStar main window 49
Unit Assignment Set Editor 248
User Access 239

Z

Zero 191

